

Fuka Brake Station - Evens-



Rudolf Fuka GmbH
Richard-Byrd-Str. 41
50829 Köln Deutschland
info@fuka.de
www.fuka.de

Ausgabe 01.05.2012

Contents

1. General data	3
2. Components.....	4
3. Dimensions.....	5
4. Spring Preload	6
5. Installation instructions	7
6. Adjustment of residual stroke.....	9
7. Adjustment of microswitches	9
8. Twin brake release actuators	10
9. Contact.....	11

1. General data

	Compliance with the standard DIN EN 81-1	✓
	Infinitely adjustable brake spring	✓
	Easy to maintain bushes with failsafe running functions	✓
	equable release of brake shoes adjustable brake arms	✓
	High braking effect due to high adhesion factor of brake pad Jurid 940	✓
	All parts galvanized	✓
	Brake arm monitoring	✓
	Installation less than one hour	✓
	Solenoid	Kuhse type GSd; 40% ED; various voltages
	Adhesion factor of brake pad	$\mu = 0,41$

2. Components

Monitoring device for brake arm

Solenoid (Kuhse GSd)

Adjustment screw for solenoid

Compressing spring

Adjustment for spring preload

Adjustment for brake shoe

Brake shoe

Bracket individually



3. Dimensions

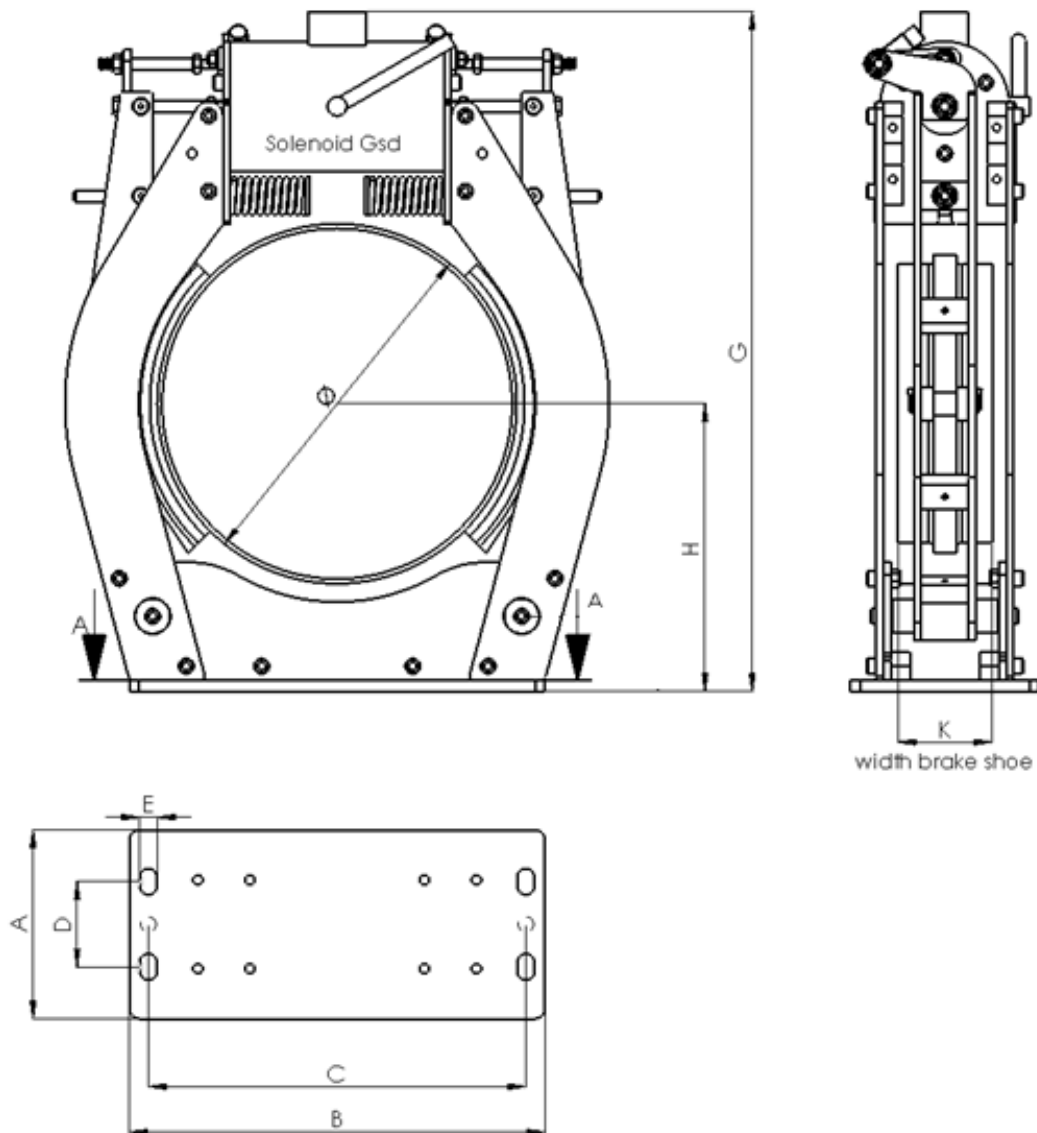

Drum →	8"	10"	12"	15"
A	155 mm	170 mm	170 mm	200 mm
B	260 mm	332 mm	400 mm	440 mm
C	225 mm	267 mm	330 mm	394 mm
D	125 mm	134 mm	134 mm	130 mm
G	520 mm	570 mm	620 mm	720 mm
H	185 mm	210 mm	235 mm	305 mm
K	80 mm	80 mm	80 mm	100 mm
Braking torque	178 Nm	230 Nm	253 Nm	487 Nm
Solenoid	Gsd 135	Gsd 135	Gsd 135	Gsd 136

4. Spring Preload

Evens	Solenoid	F Solenoid [N]	Spring Dim. [mm]	Spring Rate [N/mm]	Color	A [mm]	B [mm]	C [mm]	F _{res} N/mm	Pretension max. [mm]
8"	Gsd135	1000	32 x 16 x 64	99	blau	135	265	360	1358	12
10"	Gsd135	1000	32 x 16 x 64	99	blau	142	297	392	1320	12
12"	Gsd135	1000	32 x 16 x 64	99	blau	180	360	455	1264	11
15"	Gsd136	1350	32 x 16 x 64	99	blau	255	445	540	1638	15

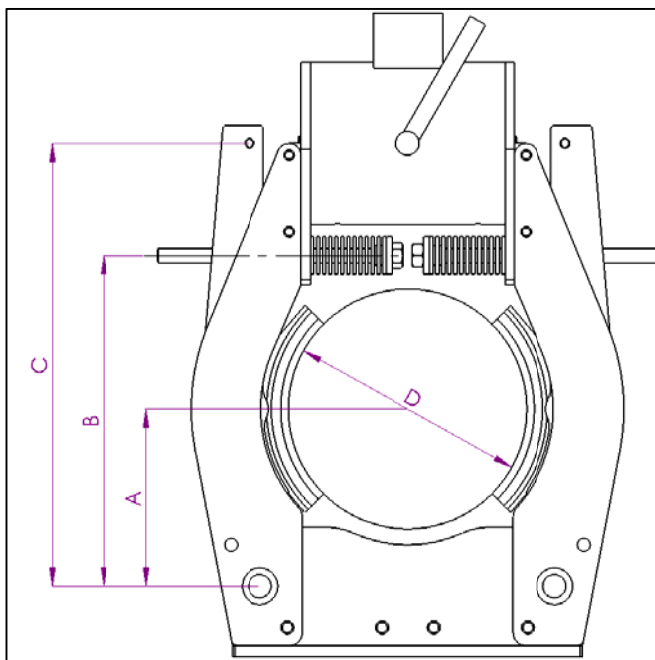

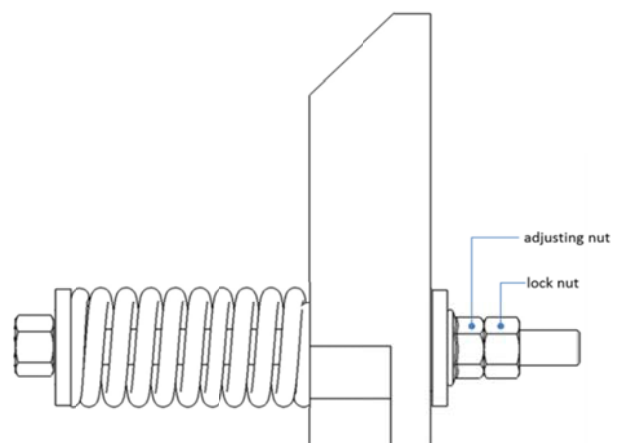

The braking moment is set by the spring preload. The spring preload of the spring has at least set so that the braking torque meets the requirements of the braking deceleration. When adjusting the spring preload, make sure that the preloaded spring force does not exceed the lifting capacity of the built-in magnets. (Pretension maximum)

To adjust the braking torque, loosen the lock nut on the spring rod. Subsequently, use the adjusting nut to preload the compression spring until the necessary preload is reached. It is important to ensure that both sides are equally biased. Tighten the lock nut and check the correct release of the brake. Then, the braking function of the system must be checked.

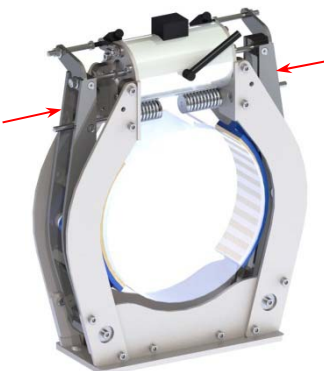

5. Installation instructions

	<ul style="list-style-type: none">▪ install bracket to the machine bed- do not tighten the screws yet <p><i>The side panels can be removed for easier installation</i></p>
	<ul style="list-style-type: none">▪ install upper part of the brake station- loosen the lower screws on both sides- put upper part over brake drum <p><i>If enough space is available, the screws stay attached.</i> <i>The upper part is then positioned from the side of the drum</i></p>
	<ul style="list-style-type: none">▪ fasten upper part to bracket
	<ul style="list-style-type: none">▪ install brake arms with brake shoes▪ press brake shoes close against brake drum▪ adjust bracket centered



- tighten the **screws** firmly
- Bracket is set on the machine bed.



- press brake shoes close against brake drum
- tighten the screws to adjust the brake shoes

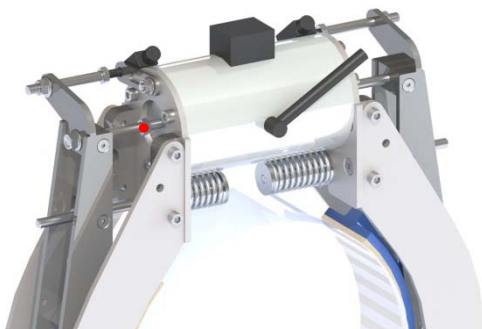

- press brake shoes close against brake drum
- turn **screw** to 1mm before plunger of solenoid
make sure that the plunger is in rear end position

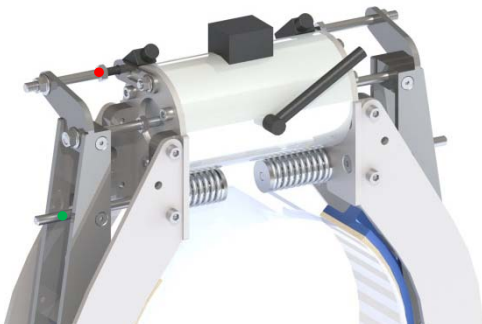

- adjust spring pre-load with **adjustment screw**
- turn **screw** until just above the switch point
make sure that the plunger is in rear end position

6. Adjustment of residual stroke

The residual stroke is set at the installed brake. Before adjusting the residual stroke, make sure that the plunger of the solenoid is completely in closed position. To adjust the residual stroke loosen the lock nut and turn the adjusting screw to 1,0 mm on the plunger of the solenoid armature. Then lock it with the lock nut. Then open and close the brake several times.

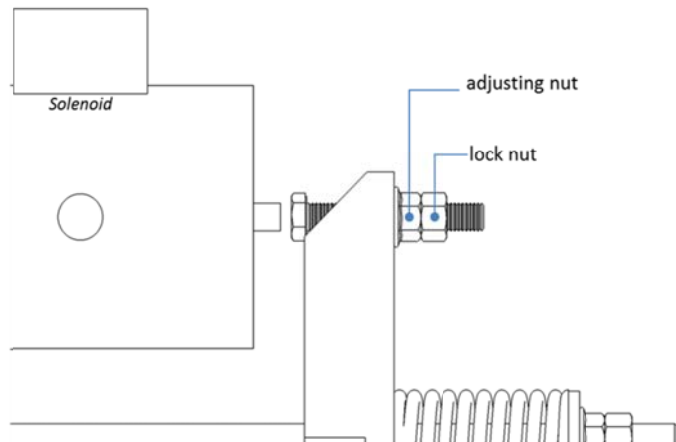

The residual stroke is steadily reduced by the wear of the brake pads. This is therefore to be checked regularly and adjusted. When depleted the residual stroke it comes to the complete failure of the brake

7. Adjustment of microswitches

The position of the micro switch can be different for different types of brakes. The presentation is only for illustration. The adjusting of the micro switches must be applied at the closed brake arms and after adjustment of the spring preload. The micro switches must be positioned so far to the inner brake lever until it comes to a marked audible click.

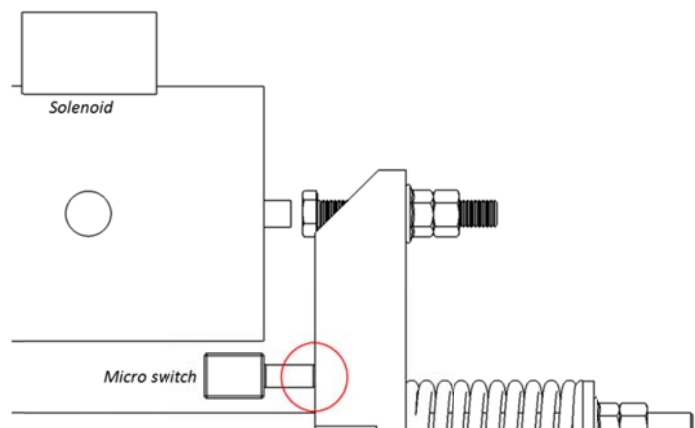

8. Twin brake release actuators

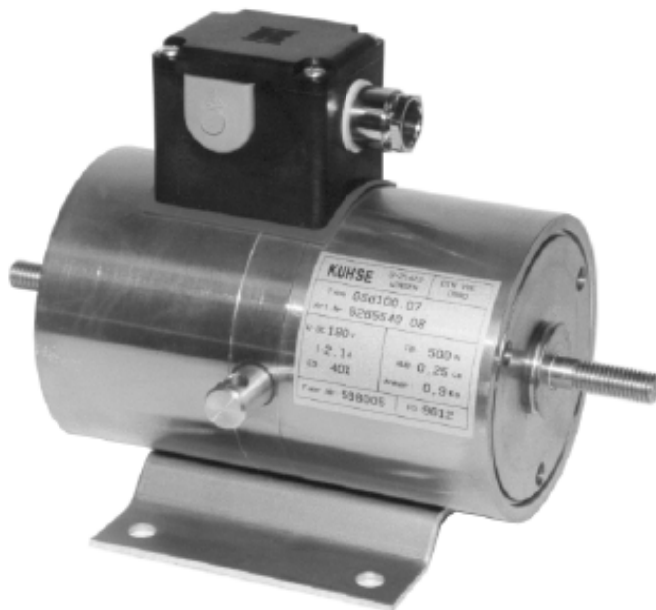

Design

Expanding solenoids of model range type GSd are produced in sizes of 99 mm to 164 mm diameter, and with stroke lengths between 2,5 mm and 4,0 mm. So, these solenoids are featuring higher rated forces as compared with solenoids of type GS of similar diameters.

The armature movements from stroke starting- to stroke limit-positions are performed by electromagnetic force; for resetting, an external power source (spring or weight) is needed.

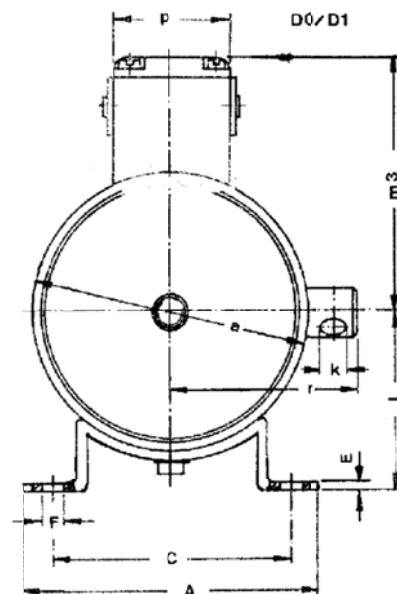
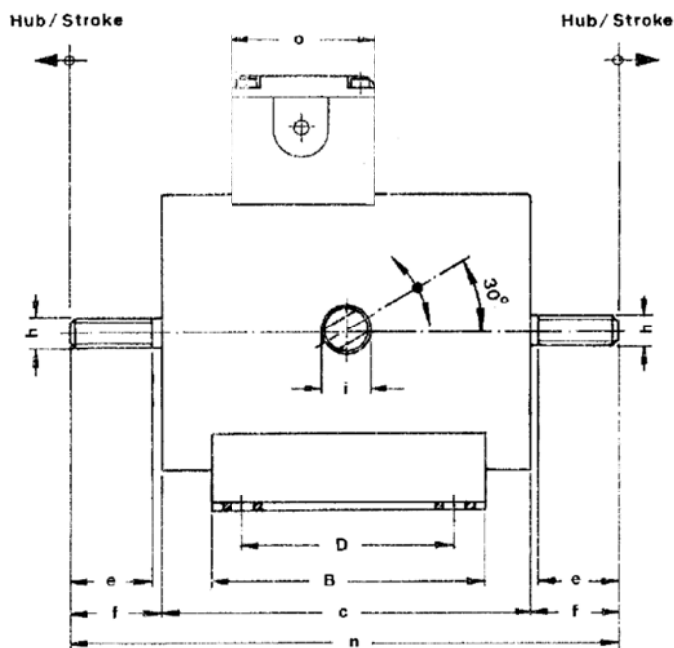

Abmessungs-Tabelle / Dimension Table [mm]																					
Type↓	a	c	e	f	h	i	k	l	m1	m2	m3	n	o	p	r	A	B	C	D	E	F
GSd 100	99	155	34	36,5	M 10	14	8	60	66	99	98	228	60	50	70	125	105	100	80	2,5	9
GSd 115	114	156	34	37,5	M 12	20	8	75	73	106	105	231	60	50	77	125	115	100	90	2,5	9
GSd 135	137	166	40	46	M 12	20	10	90	85	117	113	258	60	50	90	135	145	110	120	2,5	9
GSd 136	137	226	35	44,5	M 12	22	10	90	85	117	113	315	60	50	90	135	145	110	120	2,5	9
GSd 165	164	278	50	60	M 20	26	14	105	98	131	137	398	60	50	112	200	190	170	160	12	11

9. Contact

Frank Eßer | technical manager | modernization components

Tel.: + 49 (0)221 539958-19

Fax: + 49 (0)221 539958-55

frank.esser@fuka.de

Rudolf Fuka GmbH

Richard-Byrd-Str. 41

50829 Köln Deutschland

info@fuka.de

www.fuka.de

Ausgabe 01.07.2013

Warranty:

The warranty period for components and spare parts shall be 12 months after passing of risk, but max. 6 months after taking the system into operation.

The "General sales and delivery terms" of Rudolf Fuka GmbH apply generally.

Download at http://www.fuka.de/index.php/infos_downloads.html