

INSTRUCTIONS: Tension Pulley 200 (LBD-200)



Date: 31-03-10

Check: 05

TENSION PULLEY 200

INSTRUCTIONS: Tension Pulley 200 (LBD-200)



Date: 31-03-10

Check: 05

1- INSTRUCTIONS FOR USE AND MAINTENANCE

2- ASSEMBLY HANDBOOK

1- INSTRUCTIONS FOR USE AND MAINTENANCE

All the components are very simple and do not need a special maintenance.

The most important points that must be considered are these:

1- The assembly instructions of each tension pulley must be respected.

2- The screws for the adjustment and fixing of the tension pulleys to the guide and those for the components of the Tension Pulley have to be tightened with his respective tightening torque in order to guarantee the proper fixing and avoid a wrong tension pulley action.

3- The tension pulley situation in the guide must be correct so that the rope running in the pulley of the overspeed governor and the tension pulley, circulate properly. In this way the decreasing of the rope life can be avoided , as far as the groove of the pulley.

4- Knocks and dents must be avoided.

2.- ASSEMBLY HANDBOOK OF THE TENSION PULLEY 200

1. Once received, the Tension Pulley 200 should be unpacked and it should be checked that all its components have been received in good conditions (see enclosed components list, FC-10-42 format).

2. **ASSEMBLY OF THE CONTACT SUPPORT WITH THE GUIDE HITCH:** First the

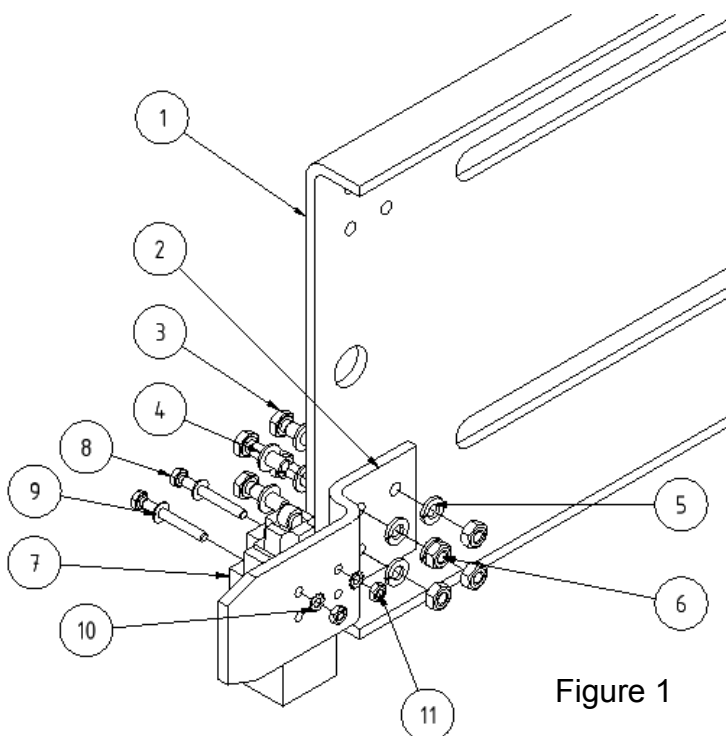

Figure 1

contact support **(2)** will be joined, with the guide hitch **(1)** by 4 screws DIN 933 M6x20 **(3)** with 4 washers DIN 125 M6 **(4)**. Then they will be fixed with 4 grower washers Grower DIN 127 M6 **(5)** and 4 nuts DIN 934 M6 **(6)**. After that the slackening contact **(7)** in the contact support **(2)**, by 2 screws DIN 933 M4x35 **(8)**, and 2 washers DIN 125 M4 **(9)**, then they will be fixed with 2 toothed washers DIN 6798 M4 **(10)**, y two nuts DIN 934 M4 **(11)**. Figura 1

3. PLACING OF THE WEIGHTSUPPORT BAR IN THE GUIDE HITCH:

Insert the hexagonal tip (12), in the hole of the guide hitch (1). It must be joined by a grower washer DIN 127 M18 (13) and a nut DIN 936 M18 (14). Once the hexagonal tip is fixed, insert the shaft of the weight support bar ensemble (15) in the hexagonal tip, insert a security ring DIN 471 D=14 (16), in order to avoid its release.

Note: Don't Screw the hexagonal tip very strong in order to avoid its breaking.

- Fig. 2 -

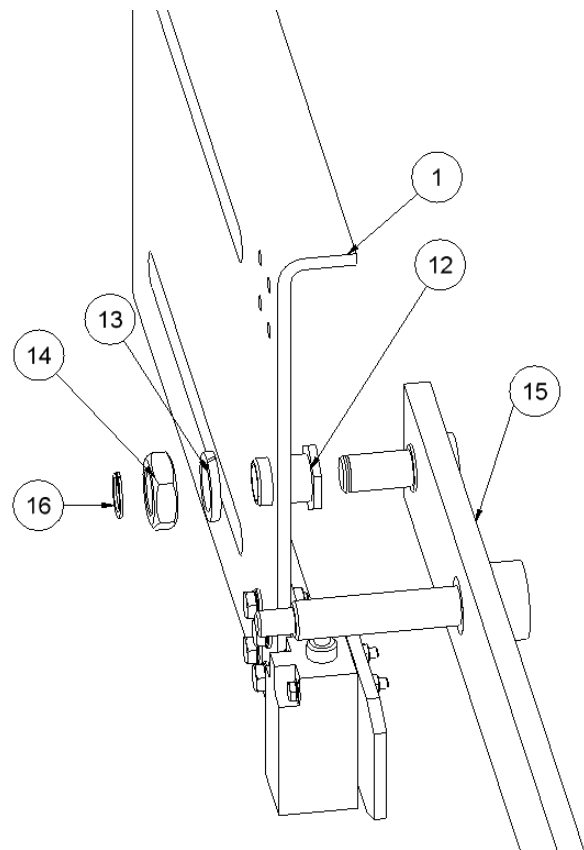

Figure 2

4. ASSEMBLY OF THE PULLEY IN THE WEIGHTSUPPORT BAR:

First insert a tip (17) and a nylon ring (18) in the shaft of the weight support bar (15). The pulley (19) will be inserted in the shaft of the weight support bar.

In order to insert properly the pulley in the shaft, place the bearing ball in the shaft straight. The adjustment of the shaft and the bearing ball should be with a hammer. Use a pipe placed in the internal ring of the bearing. Hit the pipe with the nylon hammer until the pulley make a stop in the tip.

Insert a nylon ring (18).

-Fig3-

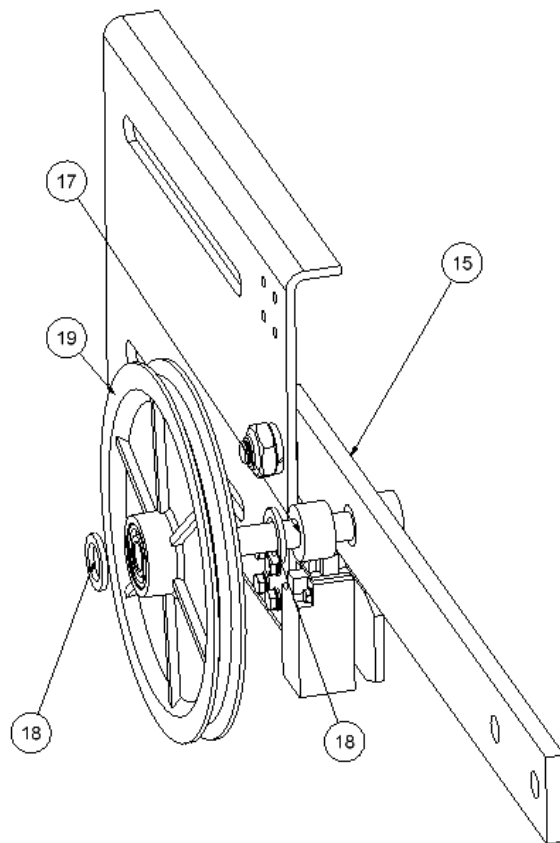

Figure 3

5. ASSEMBLY OF THE PROTECTION PLATE AND THE UNRELEASED ROPE SYSTEM:

Insert the protection plate **(20)** on the thread of the shaft. Place the plate parallel to the weight support bar. Fix it with a washer DIN 125 M10 **(24)** and one Autoblock nut DIN 985 M10 **(25)**.

The rope out protection consists of two screws DIN 933 M5x35 **(21)** Insert them in the protection plate. They will be fixed with two washers DIN 125 M5 **(22)** and two nuts DIN 934 M5 **(23)** - Fig. 4 -.

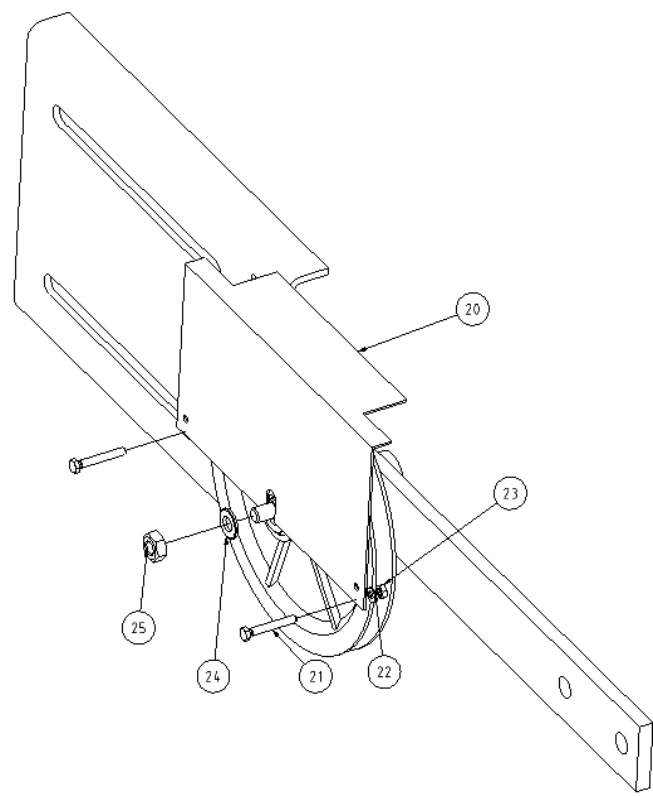

Figure 4

6. PLACING OF THE TENSION PULLEY IN THE GUIDE:

In order to place the tension pulley, use M14 flanges **(26)**.

Place the ensemble in a straight way and screw (not completely) the flanges as appears in the figure.

Note: Check visually that the hitch guide plate is on perpendicular position to the guide.

– Fig.5 -.

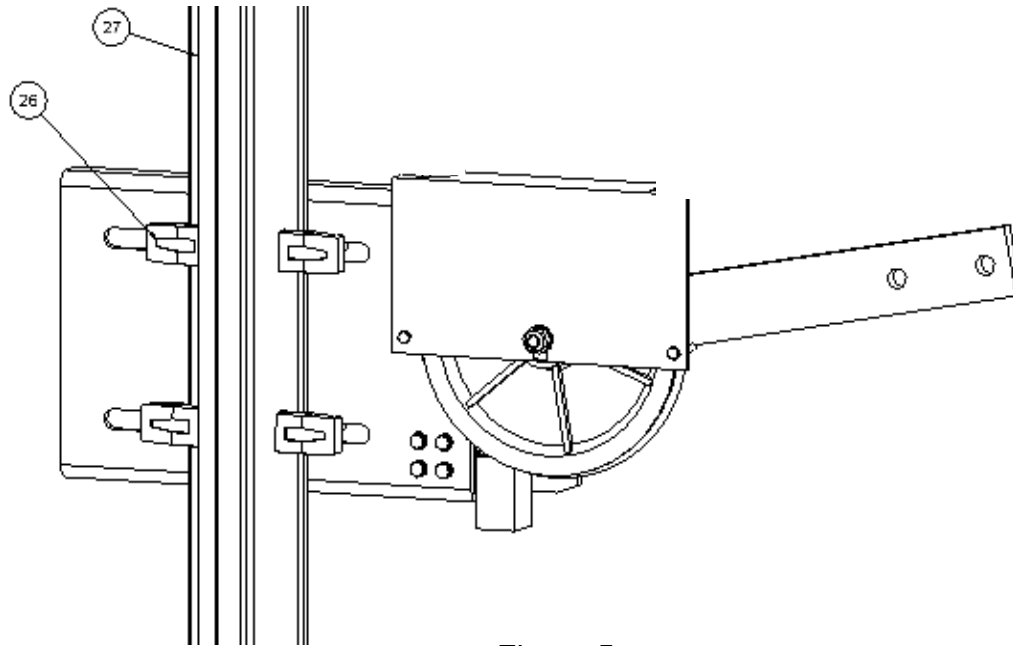

Figure 5

7. PLACING OF THE ROPE:

Once the tension pulley is placed the rope will be inserted in the groove of the pulley and inside the screws of the rope out protection system.

The weight support bar **(15)**, must be as it is shown in the figure more or less, since when the weights tensioning the rope will be joined to the bar, the pulley tension ensemble must be in straight position.

So, in order to get the weight support bar in the mentioned position, the ensemble will have to descend, use a Nylon hammer to hit in the hitch guide plate til the position of the tension pulley is the position shown in the figure 6.

Once placed properly, screw strongly the flanges on the guide.

Note: The tension Pulley must be straight except the weight support bar.

The flanges hitched to the guide will have to be straight so that the subjection surface be maximum.

-Fig.6-.

Date: 31-03-10

Check: 05

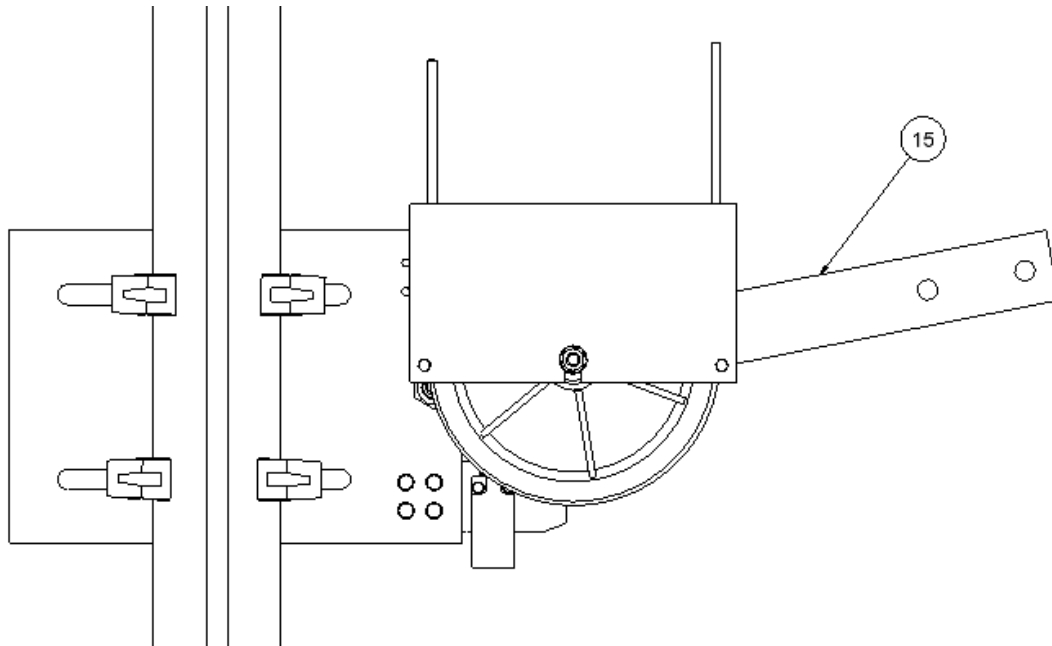

Figure 6

8. ASSEMBLY OF THE WEIGHTS IN THE TENSION PULLEY: The weights (29) will have to be joined in the position as it shown in the figure 7. Use two screws DIN 931 M14x80 (30). Fix them with two Grower washers DIN 127 M14 (32), two washers DIN 125 M14 (31) and two nuts DIN 934 M14 (33).

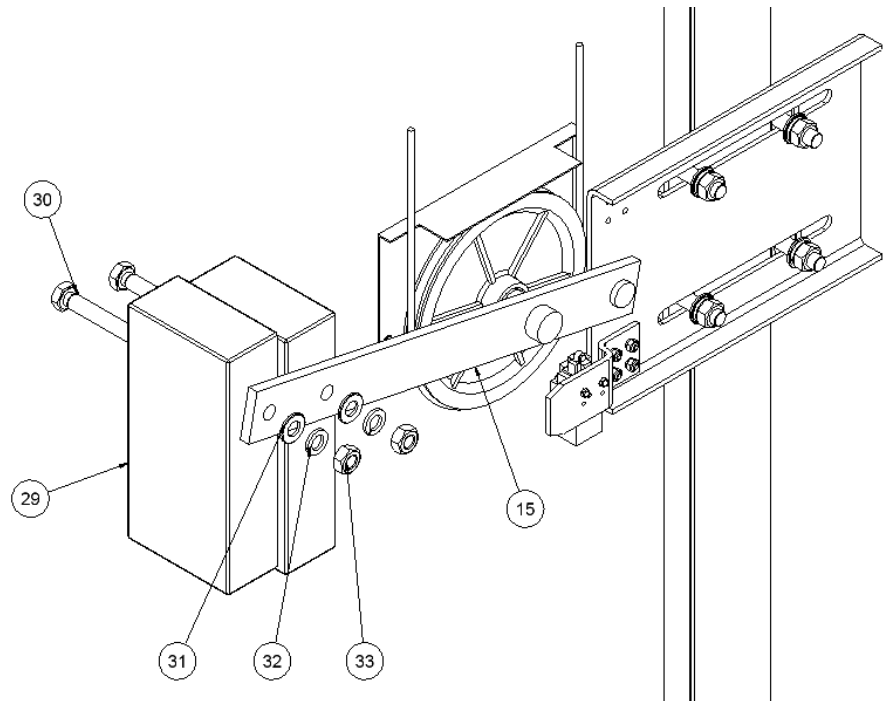

Figure 7

The Tension pulley will be as it is shown in the figure 8.

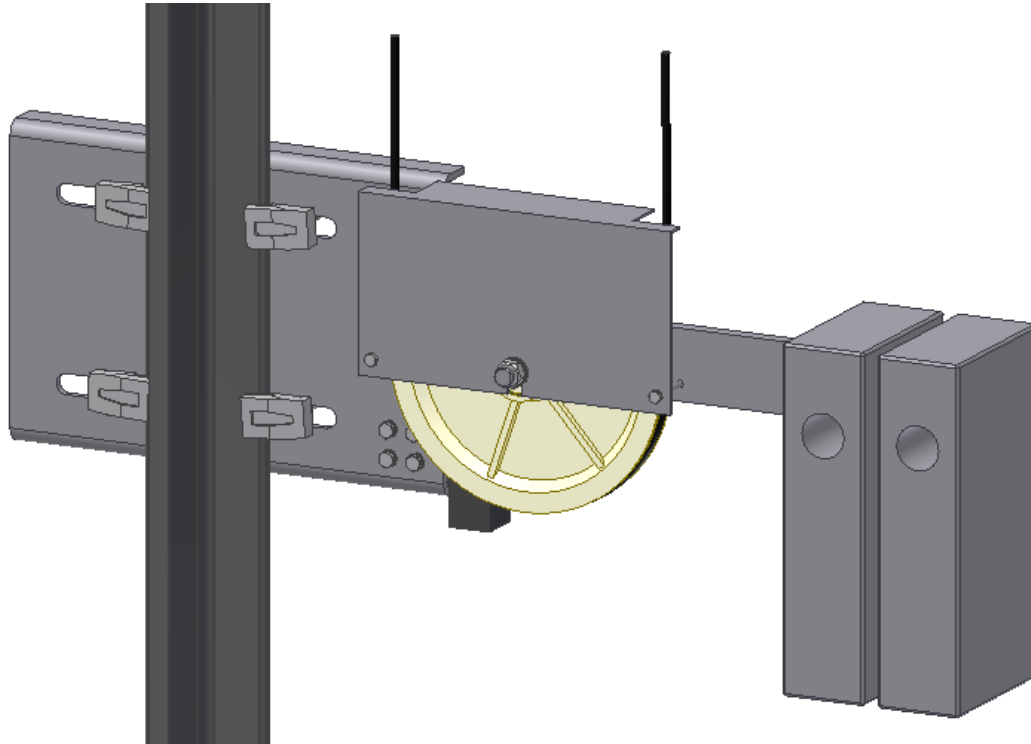
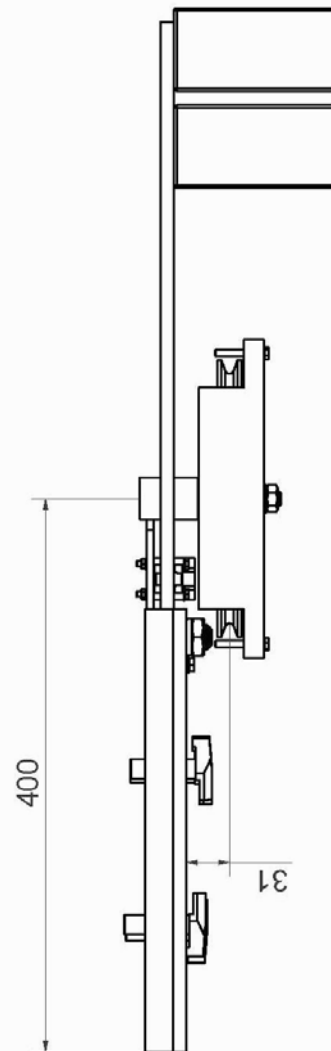
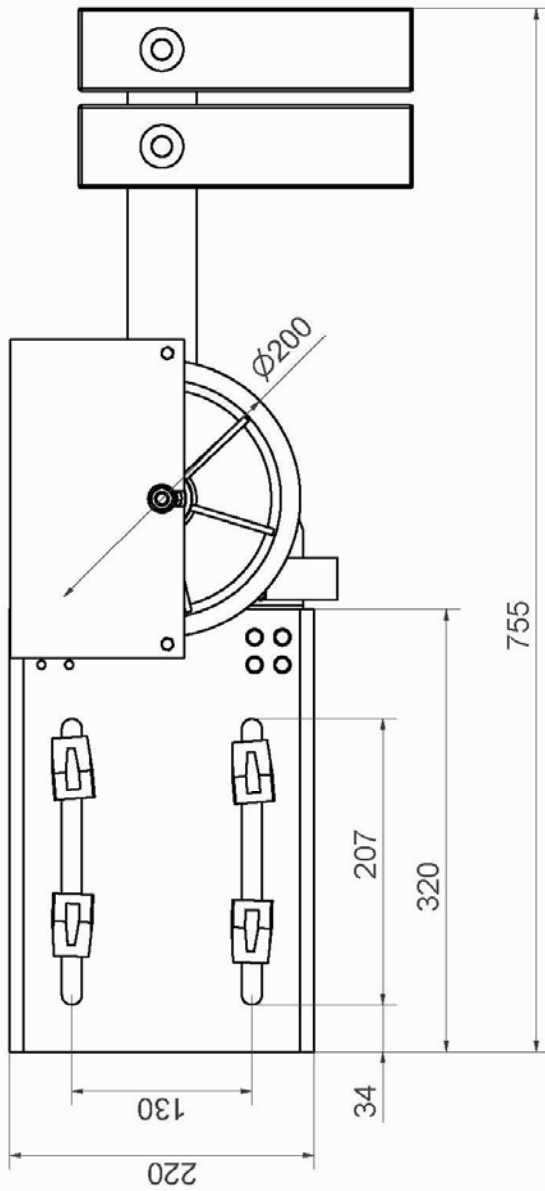
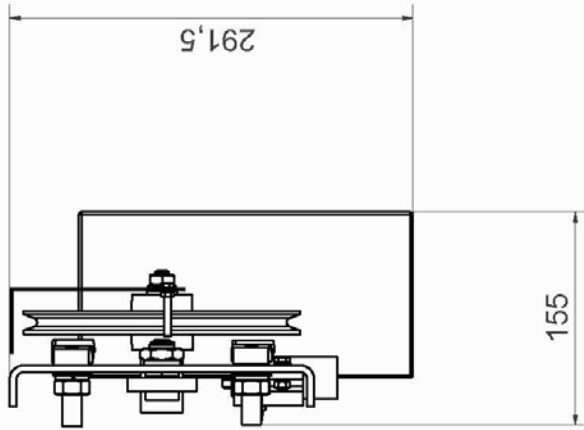
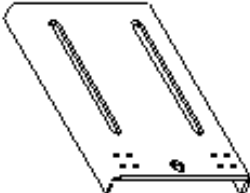

Figure 8



DYNATECH DYNAMICS & TECHNOLOGY	TENSION PULLEY 200 COMPONENTS IDENTIFICATION		CHECK: 05	CÓDIGO: FC-10-42
			DATE: 11 / 12 / 06	
			PAGE: 1 OF 1	



1 guide hitch

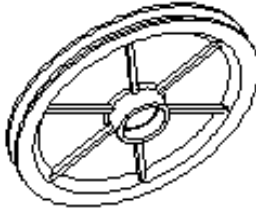

1 Pulley (with bearings)

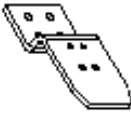

1 Contact support

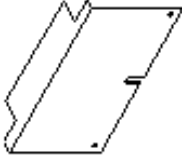

1 Protection Plate

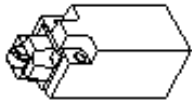

1 Slackening contact

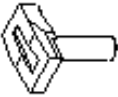

4 Flanges

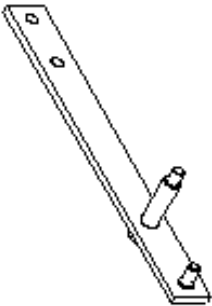

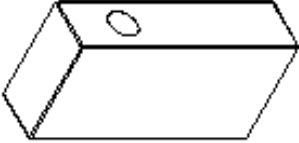

1 Weights support bar



2 Weights

SCREWS IN THE TENSION PULLEY 200

- 2 Screws DIN 931 8.8 M14x80
- 4 Screws DIN 933 8.8 M6x20
- 2 Screws DIN 933 8.8 M5x35
- 2 Screws DIN 933 8.8 M4x35
- 2 Washers DIN 125 M14
- 1 Washer DIN 125 M10
- 4 Washers DIN 125 M6
- 2 Washers DIN 125 M5
- 2 Washers DIN 125 M4
- 1 Washer Grover DIN 127 M18
- 2 Washers Grover DIN 127 M14
- 4 Washers Grover DIN 127 M6
- 2 Toothed washers DIN 6798 M4.
- 2 Nuts DIN 934 M4
- 2 Nuts DIN 934 M5
- 4 Nuts DIN 934 M6
- 2 Nuts DIN 934 M18
- 1 Autolock Nut DIN 985 M10
- 1 Nut DIN 936 M18
- 1 Security Ring DIN 471 D 12

DYNATECH DYNAMICS & TECHNOLOGY	TENSION PULLEY 200 COMPONENTS IDENTIFICATION		CHECK: 00	CODE: FC-10-61
			DATE: 09/07/08	
			PAGE: 1 OF 1	

- PIECES TENSION PULLEY 200**
- (1) Guide hitch
 - (2) Contact support
 - (7) Slackening contact Omron D4N 4132
 - (12) Hexagonal Tip
 - (15) Weights support bar
 - (17) Tip
 - (18) Nylon ring (2 units)
 - (19) Pulley (with bearing)
 - (20) Protection plate
 - (26) Flanges (4 units)
 - (29) Weights (2 units)
- SCREWS IN THE TENSION PULLEY 200**
- 2 Screws DIN 931 8.8 M14x80 (30)
 - 4 Screws DIN 933 8.8 M6x20 (3)
 - 2 Screws DIN 933 8.8 M5x35 (21)
 - 2 Screws DIN 933 8.8 M4x35 (8)
 - 2 Washers DIN 125 M14 (31)
 - 1 Washer DIN 125 M10 (24)
 - 4 Washers DIN 125 M6 (4)
 - 2 Washers DIN 125 M5 (22)
 - 2 Washers DIN 125 M4 (9)
 - 1 Washer Grover DIN 127 M18 (13)
 - 2 Washers Grover DIN 127 M14 (32)
 - 4 Washers Grover DIN 127 M6 (5)
 - 2 Toothed washers DIN 6798 M4 (10)
 - 2 Nuts DIN 934 M4 (11)
 - 2 Nuts DIN 934 M5 (23)
 - 4 Nuts DIN 934 M6 (6)
 - 2 Nuts DIN 934 M14 (33)
 - 1 Nut DIN 936 M18 (14)
 - 1 Autblock Nut DIN 985 M10 (25)
 - 1 Security Ring DIN 471 D 12 (16)

