



P4GU VolTE

4G MOBILE NETWORK GATEWAY
EQUIPMENT FOR ELEVATORS



SUMMARY

SUMMARY	2
GENERAL WARNINGS	5
General Remarks	5
DESCRIPTION	6
Main Features	7
LEDS	7
INSTALLING	9
Tips for installation	9
Consumption table	9
Fixation	10
Inserting the SIM card	11
Installing the antenna	12
Remote alarm	13
Connecting the power supply / battery	14
STARTING	15
PROGRAMMING BY PHONE	16
How to use	17
Roaming configuration	17
Setting the country	17
Adjusting the Transmit/Receive Gain	17
Setting the call codec	18
Telephone number for administration	18
Programming password	18
Dialed Telephone Number Converter	18
2G, 3G, 4G signal level measurement	19
Setting the network type	19
Telephone number for notification	19
Battery Alert	19
Telephone line voltage	20
External power supply fault check	20
Reading battery status	20
Restarting (rebooting)	20
Factory Reset	20

SUMMARY

PROGRAMMING BY SMS	<u>21</u>
Message format	<u>21</u>
Mode / Reading mode of use	<u>22</u>
Configuration / Désactivation of roaming	<u>22</u>
Reading the Roaming status	<u>22</u>
Read / Set country code	<u>22</u>
Reading / Adjusting the transmitter gain	<u>23</u>
Reading / Adjusting the receiver gain	<u>23</u>
Reading / Setting the call codec	<u>23</u>
Definition / Deletion / Reading of the administrator number	<u>23</u>
Programming password settings	<u>23</u>
Dialed Telephone Number Converter	<u>24</u>
Entering / Deleting a pre-recorded number	<u>24</u>
Deleting all pre-stored numbers	<u>24</u>
Playing pre-recorded Nos	<u>24</u>
2G / 3G / 4G signal level measurement	<u>24</u>
Reading / Setting the type of network	<u>25</u>
Definition / Deletion / Reading of the notification number	<u>25</u>
Definition / Reading of the Tel. ANEP protocol	<u>25</u>
Entering / Reading ANEP protocol identifier	<u>25</u>
Enabling / Disabling the battery charge level check	<u>26</u>
Reading the battery charge level check	<u>26</u>
Voltage / Reading Telephone Line Voltage	<u>26</u>
Enabling / Disabling external power supply control	<u>26</u>
Reading the external power supply control	<u>26</u>
Identifying the type of gateway	<u>27</u>
Reading battery status	<u>27</u>
Remote update [DATA flat rate required]	<u>27</u>
Restarting (rebooting)	<u>27</u>
Factory Reset	<u>27</u>

SUMMARY

ADJUSTING THE GAIN	28
AUTOMATIC PHONE NUMBER CONVERTER	29
MEASURE THE SIGNAL LEVEL	31
BATTERY ALERT	32
EXTERNAL POWER FAILURE MONITORING	33
READING ADVANCED GATEWAY PARAMETERS	34
BATTERY STATUS READING	35
REBOOT	36
FACTORY RESET	36
SERVICE	37
SIGNALING	38
TONES	38
CALL SIGNALING	39
LEDS	39
GREEN - 2G / 3G / 4G network strength	39
RED - Device status	40
WHITE - Line status	40
BLUE - Power status	40
PROBLEM RESOLUTION	42
WARRANTY	43

GENERAL WARNINGS

GENERAL REMARKS

Pay close attention to the warnings contained in this section as they provide important guidelines for achieving a safe installation, for correct use and maintenance of the product.

- The appliance must be intended **EXCLUSIVELY** for the use for which it was been designed and ANEP cannot be held responsible for any damage resulting from improper use.
- The product has been designed in compliance with the standards, the installation must be carried out inside compliant installations meeting appropriate standards.
- Before carrying out any intervention inside or outside the product (cleaning, maintenance, etc.) disconnect the appliance from the main power supply and the battery.
- For any repair work, please contact our service exclusively after-sales SAVTEL.
- Install the product in a ventilated room taking into account the ventilation which does not must in no case be obstructed.
- Do not install the product in a potentially explosive environment.
- Ensure that the product is installed according to the prescribed indications.
- Do not introduce objects, liquids or dust, do not use a spray inside the product.
- The packaging elements must not be left within the reach of children, because they can be potential sources of danger.
- In order to capture a better 4G GSM network, install the gateway at the highest possible in the building, ideally in high machinery, otherwise at the top of elevator shaft.



WARNING

Risk of explosion if battery is replaced by an incorrect type.
Dispose of used batteries according to the instructions.



Electrical equipment must be compulsorily recycled according to Directive n°2012/19/EU relating to waste electrical equipment and Electronic (WEEE)

DESCRIPTION

P4GU VoLTE is a device which is connected directly to a fixed telephone or a remote alarm, makes it possible to make and receive calls via the mobile network. For operation, a **SIM** card is required.

P4GU VoLTE has an internal backup battery (to be connected)

GATEWAY
P4GU VoLTE

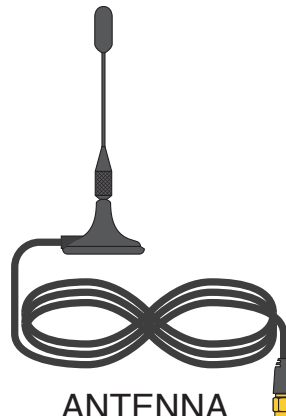

ANTENNA
(cordon 2m)

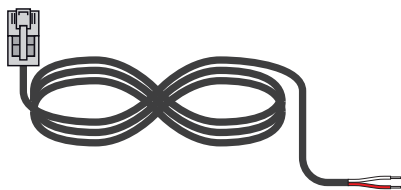

LINE CORD
(Cord 2m)

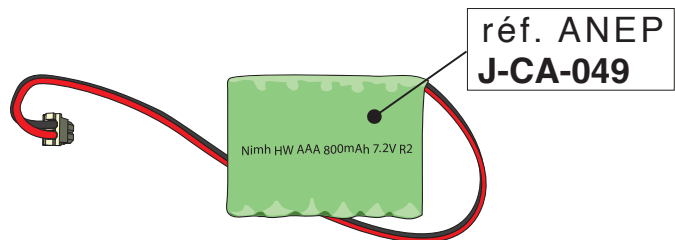

BATTERY
NI-MH 7,2V 800mAh
(To be connected)

P4GU with
Power Supply Socket

réf: **A-EA-022**

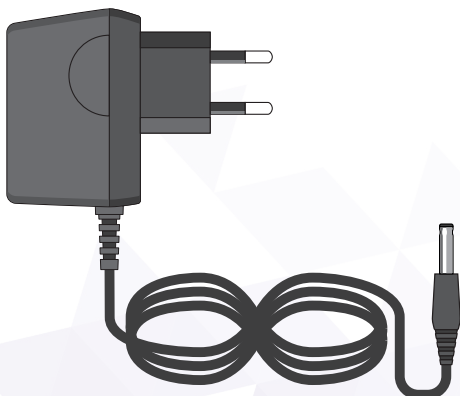

OR

P4GU with
2-WIRE Power Supply

réf: **A-EA-023**



MAIN FEATURES

- Local programming via a telephone set [DTMF]
- Remote programming via SMS
- Roaming service management (roaming)
- Control of the absence of electrical network
- Remote firmware update (**with data plan**)
- Checking the battery charge level
- Power failure notification SMS
- Power restored notification SMS
- Battery exhausted notification SMS
- State of the power supply under ANEP protocol
- Fallback mode: connection to the 4G network, otherwise 3G, otherwise 2G (voice only)
- Reading of 2G, 3G or 4G signal level
- Automatic converter of selected number
- Setting transmit and receive gains
- Remote reset
- Remote firmware update (internal software)
- Mobile network intensity signaling LED
- Device status LEDs
- Line status indicator LED
- Power status indicator LED
- Dual Band Module (European 4G Network)
- Transmit power 2W
- Input for direct 12Vdc power supply
- Input for transformer power supply. external 230Vac / 12Vdc
- External antenna (cable L = 2m) / (antenna with optional 10m cord)
- Plug-in or two-wire external adapter (input 230Vac 50 Hz, output 12Vdc 500mA)
- Dimensions: 140 x 96 x 28mm
- Weight: 220g

LEDS

The **P4GU VoLTE** device has 4 LEDs visible on the outside. For the meaning of the flashing of each of the LEDs, consult the chapter "Signals" (see pages 39 to 43).



Green LED: intensity of the mobile network in 2G, 3G or 4G



Red LED: device status



White LED: line status



Blue LED: power status



> Remove the cover by acting on the upper side.

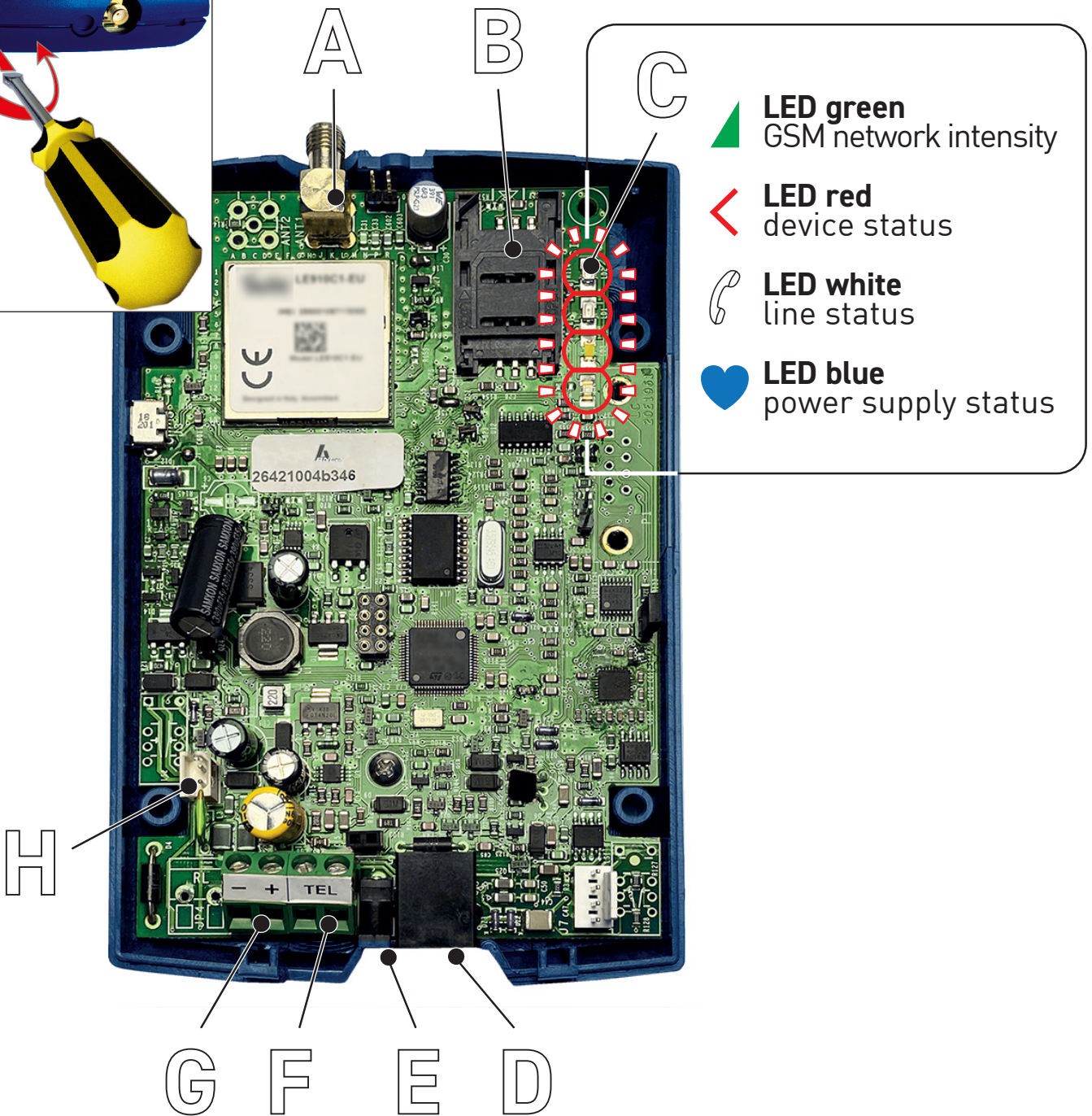

- A ANTENNA cable SMA connector
- B Slot for the SIM card (**standard SIM format 2FF**)
- C 2G, 3G, 4G network reception level LED (green)
 Device status LED (red)
 Line status LED (white)
 Power status LED (blue)
- D RJ11 connector for connecting a fixed telephone or a remote alarm
- E Input for transformer power supply. external 230Vac / 12Vdc
- F Terminal for connecting a fixed telephone or a remote alarm
- G Connection of the external 12V power supply
- H Connecting the internal battery

INSTALLATION

Tips for Installation

- The **P4GU VoLTE** gateway must be installed in a place where the radio signal is sufficient for its correct use. In case that it is impossible to have of the network with the 2m antenna, ANEP can optionally provide a 10 m antenna (ref. A-EA-030), or a 5 m extension (ref : A-EA-025)
- It is important to have sufficient space around the device to optimized maintenance operations.
- The **P4GU VoLTE** device cannot be installed outdoors because there is no protection against atmospheric agents (rain, humidity, etc.) which could damage it.
- Do not install the **P4GU VoLTE** device near other electronics devices (radio or TV equipment, computers, television broadcasting systems, etc.) or magnetic (credit card, tickets, etc.) which may be subject to Radiofrequencies interference from the device: the recommended minimum distance is 2.5 m.
- The **P4GU VoLTE** device should not be installed near medical devices .Its use may harm hearing aids or pacemakers.
- Make sure that the use of the device at the place of installation is authorised. Should not normally be installed in hospitals, aircraft, etc.

Consumption table

Power supply	10Vdc	12Vdc	13,8Vdc	10Vdc	12Vdc	13,8Vdc
	(internal battery disconnected)			(internal battery connected)		
Handset on hook	30mA	30mA	25mA	40mA	60mA	50mA
Off-hook	90mA	80mA	70mA	100mA	105mA	90mA
Talk	130mA	115mA	110mA	140mA	135mA	130mA
SMS transmission	75mA	60mA	55mA	85mA	80mA	75mA

INSTALLATION

1 ATTACHMENT

Check the mobile network strength by the green network strength LED (see chapter “**Signals**”, page 39)

Locate an area where the GSM signal is sufficient, ANEP recommends 3 flashes of the green LED.

Note: The network may vary depending on the telephone company.

- Make two holes of $\varnothing 5$ mm in diameter on the wall spaced between them by 50 mm.
- Insert the 2 dowels and tighten the screw up to 5 mm away from the wall.
- Insert the P4GU VoLTE device, through the two posterior eyelets, on the 2 screws from the wall.

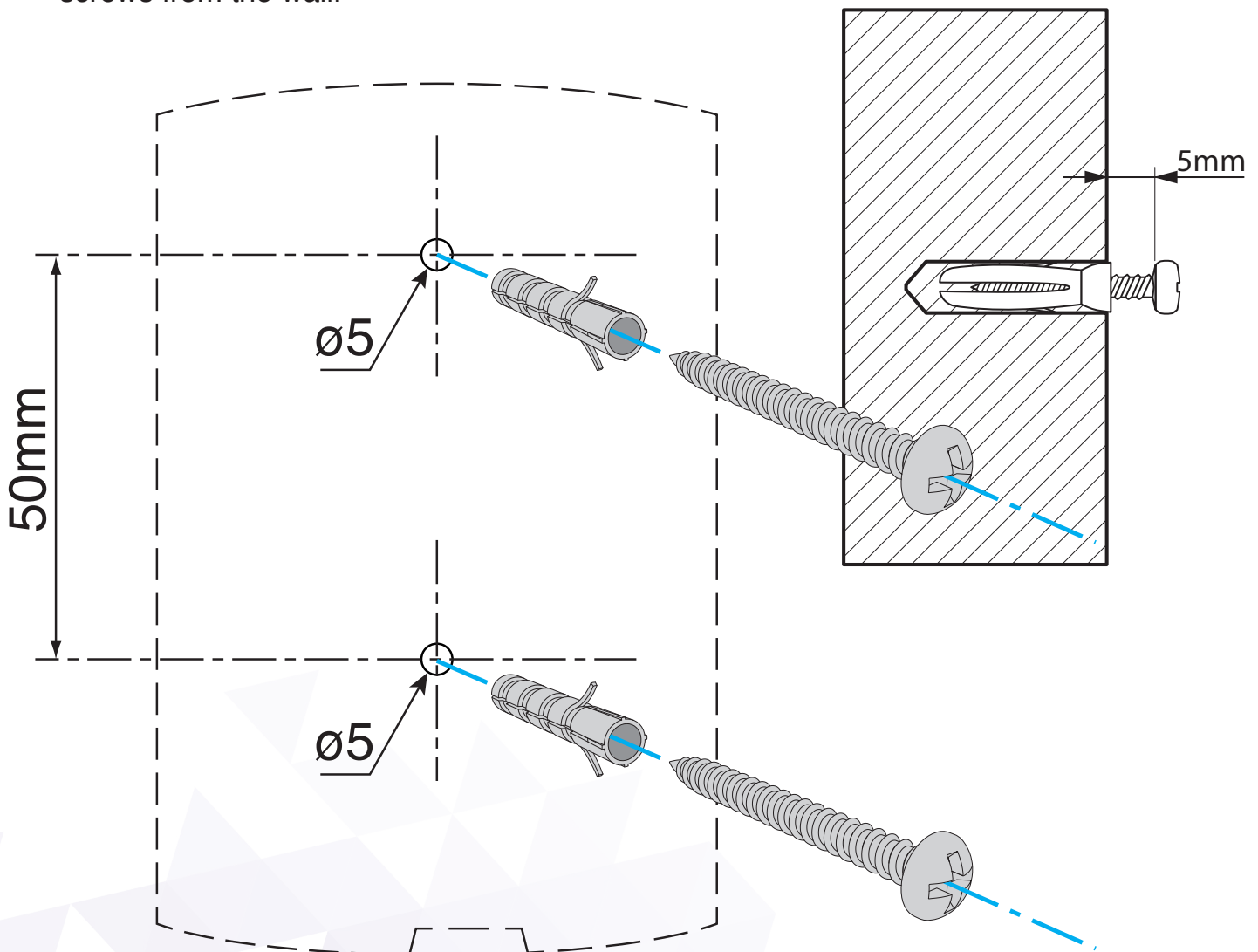

INSTALLATION

2 SIM CARD

(STANDARD SIZE 2FF)

Before inserting the SIM card, make sure you are electrostatically discharged and that the device is switched off to avoid damaging it.

Use all precautions to avoid electrostatic discharge.



ATTENTION

The SIM card must have the PIN CODE DEACTIVATED.
If the SIM card has the PIN CODE activated, it must be deactivated using a cell phone

Gently push the front part of the SIM card slot down (until it releases) and lift it up.

Slide the SIM card into the slot on the front panel.

Lower the front part and push it up until it locks.

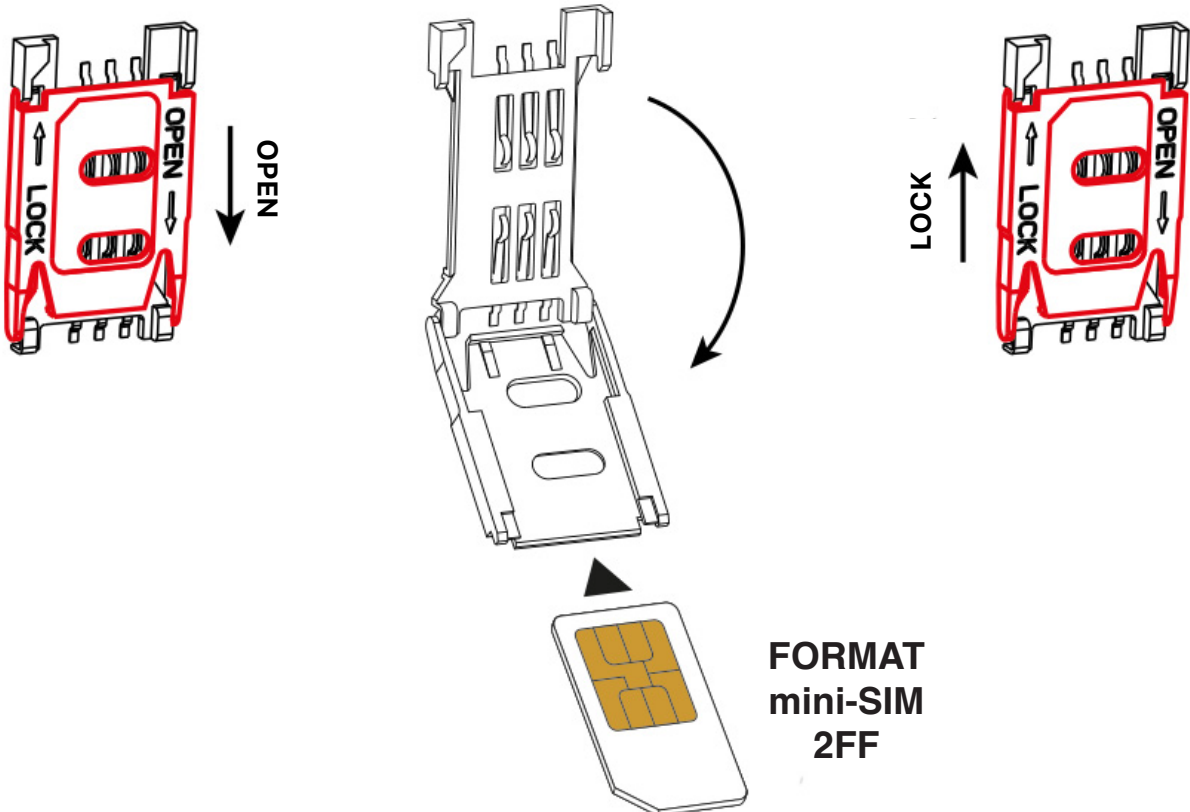

INSTALLATION *(continued)*

3 ANTENNA



WARNING

To avoid damage to the device.
NEVER power the P4GU
without first installing the antenna

Screw the cable (2m) of the supplied antenna
into the SMA connector
(A in picture page 8)

To ensure proper operation of the
correct operation of the **P4GU VoLTE**,
place the magnetic base antenna
so that there are no metal structures that
structures that may mask the signal.



YES

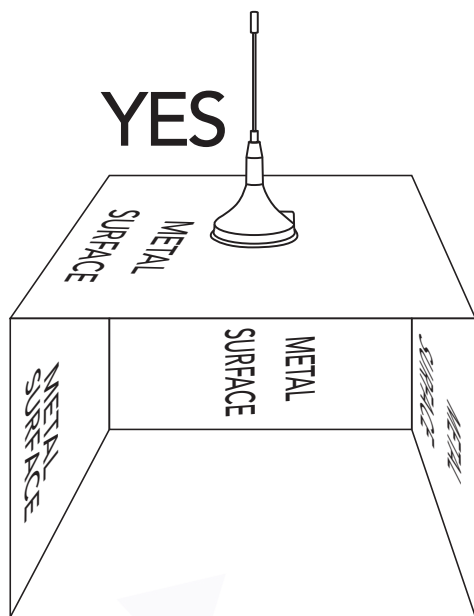

NO

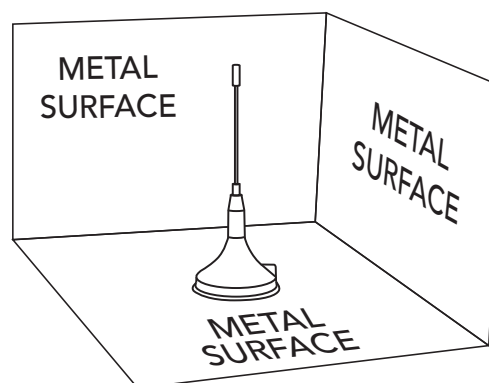

WARNING

Do not install the product near other electrical appliances or
electronic devices that were not designed to be associated with it
and which could be a source of disruption or interference.

INSTALLATION (continued)

4 TELEALARM

Plug through of the RJ11 connector (D see photo page 8) the P4GU VoLTE device to a landline phone or a remote alarm.

or

Connect via the TEL terminal (F see photo page 8) the P4GU VoLTE to a landline telephone or a remote alarm.

Scheme of connection range ANEP BOX

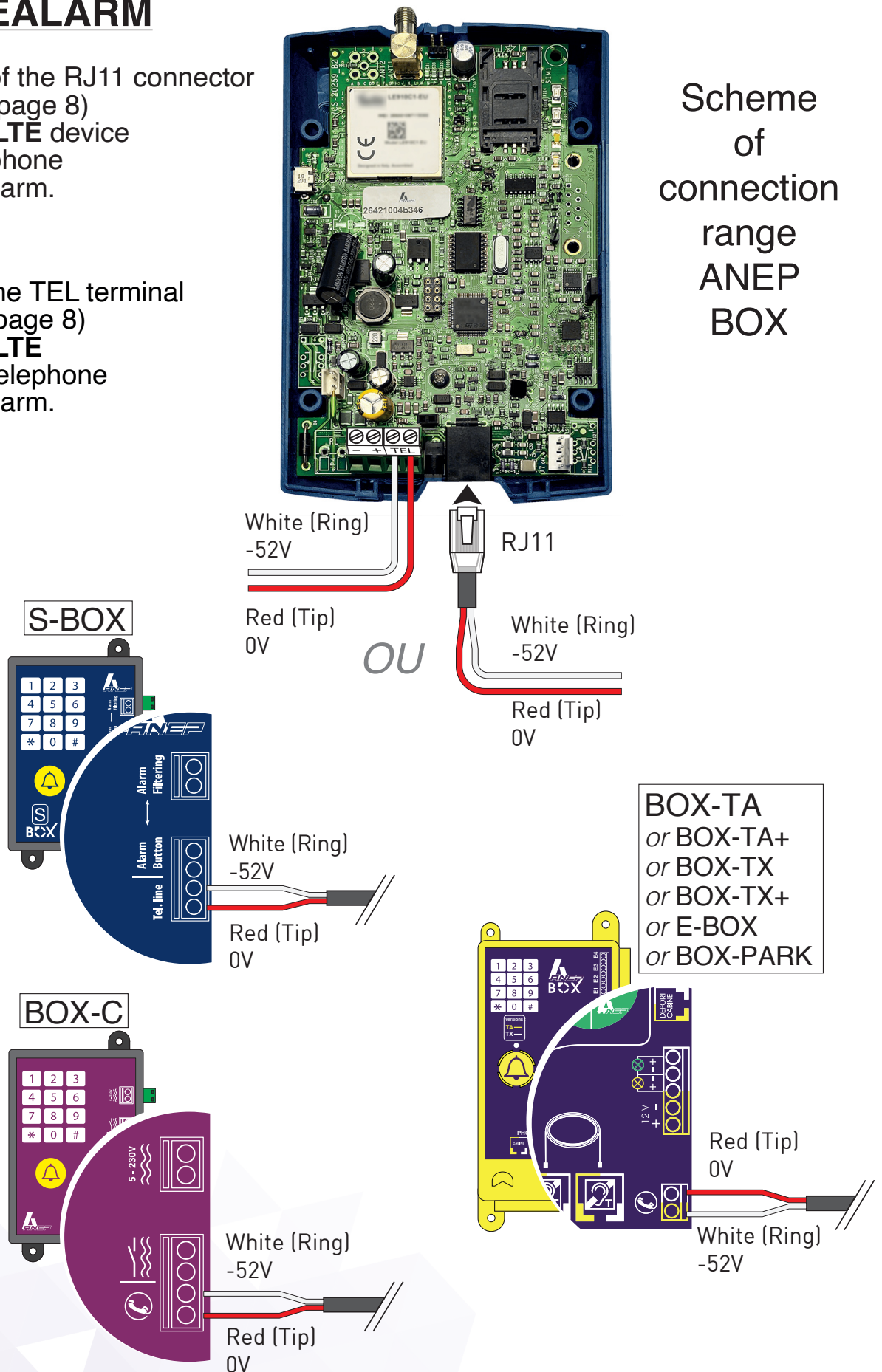

INSTALLATION (continued)

5 POWER SUPPLY by TRANSFO 230Vac / 12Vcc

Power supply by external adapter
230Vac / 12Vcc on terminal **E**

Connect the external adapter
to the **E** input (see photo on page 8)

Nota : It is recommended to
provide upstream of the product
an appropriate electrical protection
appropriate electrical protection,
in order to to cut off the power supply
in the event of a fault.

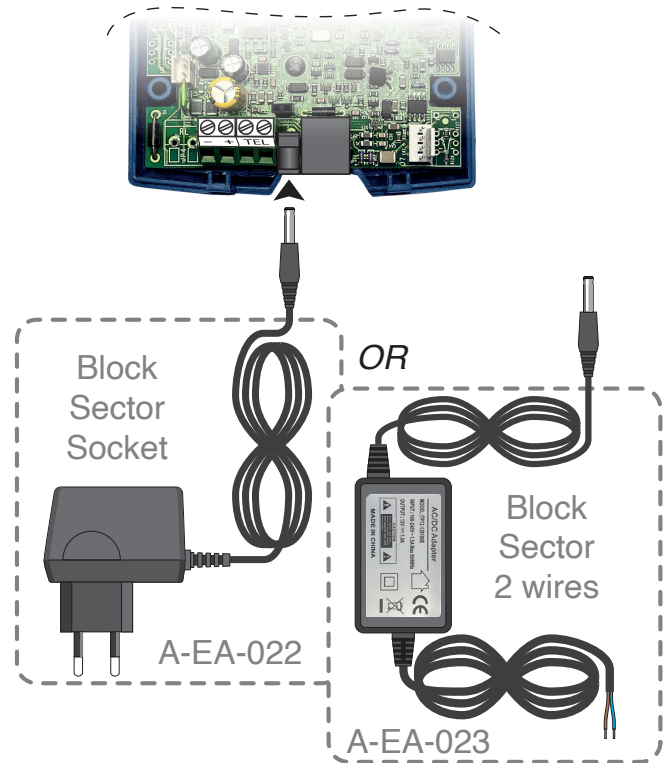

5 OR POWER SUPPLY by direct 12Vcc

Power supply by direct 12Vdc
(Terminal **G**) (see photo page 8)

Connect the power wire to **Terminal G**
(see photo page 8) in respecting the polarities

Nota : The **maximum** supply voltage
that can be supplied is 17 Vdc.
The **minimum** supply voltage
that can be supplied is 10 Vdc.

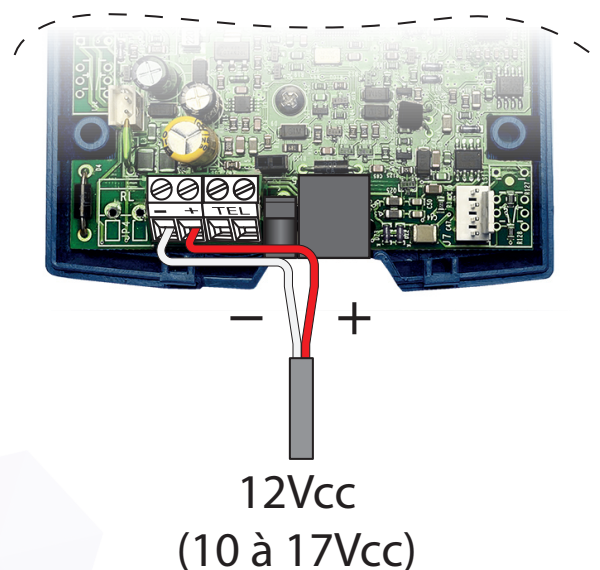

INSTALLATION *(continued)*

6 BATTERY

- Connect the battery as shown opposite

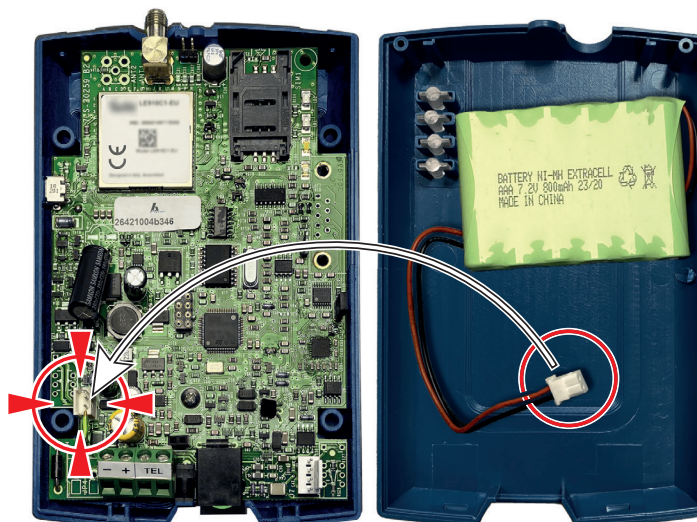

WARNING

The backup battery must be connected **after** the power supply of the **P4GU VoLTE**.

- Close the cover of the device, paying attention to the power cord.

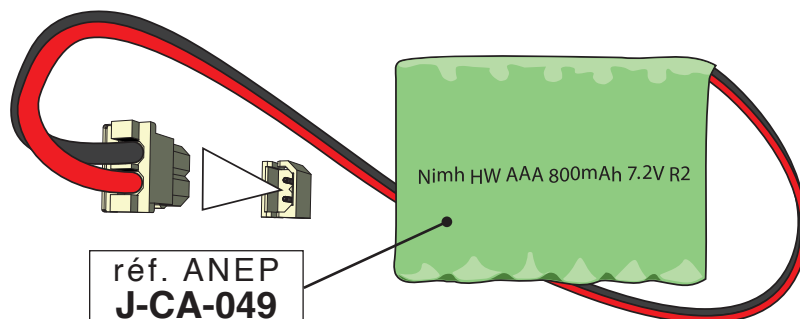

STARTING

- Power up the **P4GU VoLTE** device (see page 14)
- Wait at least 30 seconds to 3 minutes and more for proper registration of the device by the 2G, 3G or 4G mobile network
- Make sure that the device status LED (RED) blinks rapidly once every 3 seconds as once every 3 seconds as described in the chapter "**Signals**" (see page 42)
- If the red device status LED flashes faster and stays on longer (see page 42), the device is not properly connected to the 2G, 3G or 4G network
- Unplug the **P4GU VoLTE** and check if the SIM card is correctly inserted or not blocked by the PIN code.
- See also the chapter "**PROBLEM RESOLUTION**" (see page 43)

PROGRAMMING BY PHONE

Allows the customization of the device according to your own needs. Programming can be done manually using a multi-frequency telephone equipped with a keyboard.

It is possible to program :



= (pick up the phone)

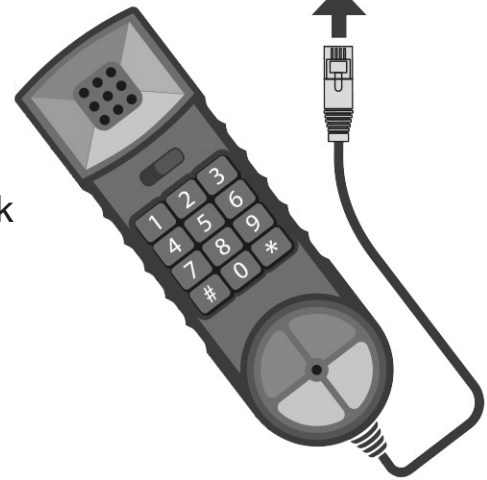

- The configuration of the roaming service
- The number for SMS warning
- The number of the administrator
- The programming password
- Control of the battery charge level
- Control of the absence of the electrical network
- Automatic converter of the selected number
- Receiver gain setting
- Transmitter gain setting
- Front-end call number
- Gateway ID number

Nota : During programming, no more than 5 seconds must pass between one digit and the next. At the end of the 5 seconds without digits there will be a deterrent tone and it will be necessary to hang up.

Nota : At the end of each setting, if it is correct, there will be a confirmation tone. If it is incorrect, there will be an error tone. In any case, the tone of invitation to selection will follow and it will be possible to proceed with the programming and make a call.

Nota : It is possible to carry out the settings even without a network. After the confirmation or error tone there will be a tone indicating that there is no network. It is possible to continue programming or to hang up.

PROGRAMMING BY PHONE

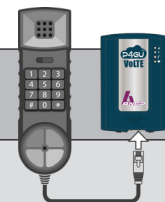

Code	Function	format	Descriptions / Informations
------	----------	--------	-----------------------------

*Note: In the "Programming by telephone" table the value programmed at the factory is shown in **bold** type.*

2X	HOW TO USE	**2X#	X : option from 1 to 2 1 = mobile network line tones 2 = line tones generated by 4G VoLTE (recommended mode for remote alarms or other other devices that perform line tone monitoring) line tones)
5	ITINERANCE (roaming)	**5*1#	Activated
		**5*0* XXX...Y#	Disabled XXX: MCC of your telephone operator Y...Y: MNC of your telephone operator (When roaming is disabled, in case the gateway registers with from a supplier other than the one who is programmed, it is not possible make or receive calls)
		Roaming enabled by default	
9	SETTING FROM THE COUNTRY	**09* X...X#	X...X: the telephone country code where the gateway is installed
		Default: automatic country setting	
10	SETTING TRANSMISSION GAIN (1)	**10*X#	X: choice of 1 (min) to 7 (max) 4 = default (do not modify unless strictly necessary)
11	SETTING RECEPTION GAIN (2)	**11*X#	X: choice from 1 (min) to 5 (max) 3 = default (do not modify unless strictly necessary)

PROGRAMMING BY PHONE

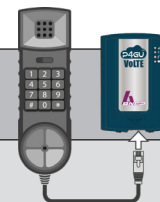

Code	Function	format	Descriptions / Informations
15	SETTING CALLS CODEC (VOICE)	**15*X#	X: option, from 0 to 128 0 = all codecs enabled 1 = RF enabled 2 = EFR enabled 4 = RH enabled 8 = AMR-FR enabled 16 = AMR-HR enabled 32 = GSM-AMR-WB enabled 64 = UMTS-AMR-NB enabled 128 = UMTS-AMR-WB enabled
18	Phone Number FOR ADMINISTRATION	**18*X...X# *X...X#	Phone number with country code (if programmed, this is the only number from which SMS programming is allowed)
		**18#	Erase
19	PROGRAMMING OF PASSWORD	**19*X...X# *Y..Y*Y..Y#	X...X: old password (max. 3 digits) Y...Y: new password (max. 3 digits) 0 by default
25 26	AUTOMATIC DIALED PHONE NUMBER CONVERTER (3)	**25* X...X*Y* Z...Z* Z...Z#	ENTERING THE COUPLING CALL NUMBER X...X: programming password Y: table position, from 1 to 6 Z...Z: telephone number
		**25* X...X*Y#	DELETING THE PAIRING CALL NUMBER X...X: programming password Y: table position, from 1 to 6
		**25* X...X*#	ERASING ALL PAIRING CALL NUMBERS X...X: programming password
		**26* X...X*Y* Z...Z* Z...Z#	ENTERING THE ROUTING CALL NUMBER X...X: programming password Y: table position, from 1 to 6 Z...Z: telephone number
		**26* X...X*Y#	ERASING THE ROUTING CALL NUMBER X...X: programming password Y: table position, from 1 to 6
		**26* X...X*#	ERASING ALL ROUTING CALL NUMBERS X...X: programming password

PROGRAMMING BY PHONE

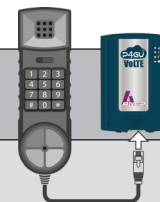

Code	Function	format	Descriptions / Informations
30	LEVEL MEASUREMENT SIGNAL 2G / 3G / 4G (4)	**30#	tone. no network = no network 1 tone = Weak Signal 2 tones = Medium Signal 3 tones = Signal Good 4 tones = High Signal
33	SETTING NETWORK TYPE	**33*X#	X: choice from 0 to 6 0: 2G GSM 1: 2G GSM / 3G UMTS 2: 3G UMTS 3: 4G LTE 4: 3G UMTS / 4G LTE 5: 2G GSM / 4G LTE 6: 2G GSM / 3G UMTS / 4G LTE
40	Phone Number FOR NOTIFICATION	**40*X...X *X...X#	X...X: Designated phone number for SMS notification of battery status, failure/restoration of external power supply, mobile network and for SMS reading of SIM card expiration.
		**40#	Erase
42	DEFINITION OF THE TEL NUMBER. ANEP PROTOCOL	**42*X...X *X...X#	X...X: telephone number designated to receive the ANEP protocol
44	CAPTURE IDENTIFIER ANEP PROTOCOL	**44*X...X *X...X#	X...X: identification number of the BOX (8 digits), or other ANEP product
52	THRESHOLD BATTERY (5)	**5X#	X: Choice of 0 to 1 0 = Alert enabled (default) 1 = Alert disabled
		**52*X#	X: Choice of 0 to 7 0 = 7 hour 1 = 6:30 a.m. 2 = 6:00 a.m. 3 = 5:30 a.m. 4 = 4 hour (default) 5 = 2.5 hours 6 = 1.5 hours 7 = 1:00 a.m. (Minimum number of operating hours, in backed up mode, guaranteed by the battery charge) Below this threshold, a notification SMS is sent.

PROGRAMMING BY PHONE

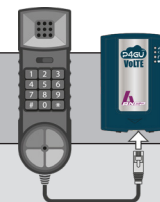

Code	Function	format	Descriptions / Informations
61	LINE VOLTAGE TELEPHONE	**61*X#	X: choice from 0 to 1 0 = 36 VDC 1 = 52 VDC
81	CONTROL BREAKDOWN FOOD EXTERNAL (6)	**81* XXYY#	XX: minutes of external power failure, from 01 to 99 YY: External power recovery minutes, from 01 to 99
		**81*0#	Deactivation
		Control disabled by default	
91	READING STATE OF THE BATTERY (8)	**91#	Tones: 0 tone = Battery absent, not connected, damaged 1 tone = 1 hour 2 tones = 2 hours 3 tones = up to 7 hours 4 tones = more than 7 hours
98	RESTART (REBOOT) (9)	**98#	Resetting the gateway does not modify its programming
99	RESET CONFIGURATION FACTORY (10)	**99#	Restoring factory settings does not change the programming password and settings entered for the "Automatic Dialed Phone Number Converter"
0002	WRITING MIN SE End of SESSION	**0002* XY#	X=0 <se_expire> 1800 secondes X=1 <se_expire> 900 secondes Y=0 <min_se> 1800 secondes Y=1 <min_se> 900 secondes
0087	WRITING URI MODE	**0087* X#	X=1 SIP URI X=2 TEL URI

Page 34

Page 35

Page 37

Page 37

PROGRAMMING BY SMS

Programming via SMS can be performed from any mobile phone or other device capable of sending SMS.

If the administrator number has been configured, programming via SMS is allowed only by this phone number.

An SMS notification from programming confirmation is transmitted from the P4GU to the number that sent the SMS from programming.



WARNING

SMS programming made and sent via the Internet may not work if the required format is not respected.

Message Format

Each programming SMS must contain the password allowing to access programming and the programming codes to be performed.

The message format should be as follows:

AN-GWU*xxx#c..c#

Or :

AN-GWU : beginning of the programming chain

***xxx#** : password chain (default xxx = 0)

c..c : programming code as in the table below

: programming code separator character or character end of chain

SMS notification of the return of a rejected order : **AN?GWU*xxx#c..cERR#**

PROGRAMMING BY SMS



Code	Function	format	Descriptions / Informations
2X	MODE OF USE	AN-GWU*0#2X#	X: option from 1 to 2 1 = mobile trunk tones 2 = line tones generated by 4G VoLTE (recommended mode for remote alarms or other devices performing the control line tones)
2R	READING MODE OF USE	AN-GWU*0#2R	Answer (example) AN?GWU*0#21# => The P4GU VoLTE is in mode 1
5	ACTIVATING ROAMING	AN-GWU*0#5*1#	Enabled (default)
	DISABLING ROAMING	AN-GWU*0#5*0*XXXY...Y#	Disabled XXX: MCC of your telephone operator Y...Y: MNC of your telephone operator (When roaming is disabled, in case the gateway registers with a different provider than the one programmed, it is not possible to make or receive calls)
	READ ROAMING STATUS	AN-GWU*0#5*R	
9	COUNTRY CODE SETTING	AN-GWU*0#09*X.X#	X...X = country code where the gateway is installed
	COUNTRY CODE READING	AN-GWU*0#09R	Answer (example) AN?GWU*0#09*208# => 208 = France

PROGRAMMING BY SMS



Code	Function	format	Descriptions / Informations
10	TRANSMITTER GAIN ADJUSTMENT (1)	<u>AN-GWU*</u> <u>0#10*X#</u>	<i>X: value, from 1 (min) to 7 (max)</i> 4 = default <i>(do not modify unless strictly necessary)</i>
	TRANSMITTER GAIN READING (1)	<u>AN-GWU*</u> <u>0#10R</u>	Answer (example) AN?GWU*0#10*4# => gain setting on 4
11	RECEIVER GAIN ADJUSTMENT (2)	<u>AN-GWU*</u> <u>0#11*X#</u>	<i>X: value, from 1 (min) to 5 (max)</i> 3 = default <i>(do not modify unless strictly necessary)</i>
	READ RECEIVER GAIN (2)	<u>AN-GWU*</u> <u>0#11R</u>	Answer (example) AN?GWU*0#11*3# => gain setting to 3
15	CALL CODEC SETTING (VOICE)	<u>AN-GWU*</u> <u>0#15*X#</u>	<i>X: choice from 0 to 2</i> 0: all codecs are enabled 1 = only FR GSM enabled (default) 2: all codecs are enabled, except AMR WB
	CALL CODEC READING (VOICE)	<u>AN-GWU*</u> <u>0#15R</u>	Answer (example) AN?GWU*0#15*2*# => 2 = EFR and HR activated / ANEP
18	DEFINITION OF THE ADMINISTRATOR NUMBER	<u>AN-GWU*</u> <u>0#18*X..X</u> <u>*X..X#</u>	<i>X..X: telephone number with country code (if defined, this is the only number from which programming by SMS is authorized)</i>
	DELETE ADMINISTRATOR NUMBER	<u>AN-GWU*</u> <u>0#18#</u>	
	READING THE ADMINISTRATOR NUMBER	<u>AN-GWU*</u> <u>0#18R</u>	Answer (example) AN?GWU*0#18*0# => The number is not filled in
19	PROGRAMMING PASSWORD SETTING	<u>AN-GWU*</u> <u>19*X..X*</u> <u>Y..Y*Y..Y#</u>	<i>X...X: old password (max. 3 digits)</i> <i>Y...Y: new password (max. 3 digits)</i> 0 by default

PROGRAMMATION PAR SMS



Code	Function	format	Descriptions / Informations
25	AUTOMATIC DIALED PHONE NUMBER CONVERTER (3)	<u>AN-GWU*</u> <u>0#25*</u> <u>X..X*Y*</u> <u>Z..Z*Z..Z#</u>	ENTERING THE COUPLING CALL NUMBER X...X: programming password Y: table position, from 1 to 6 Z...Z: telephone number
		<u>AN-GWU*</u> <u>0#25*</u> <u>X..X*Y#</u>	DELETING THE PAIRING CALL NUMBER X...X: programming password Y: table position, from 1 to 6
		<u>AN-GWU*</u> <u>0#25*</u> <u>X..X*#</u>	ERASING ALL PAIRING CALL NUMBERS X...X: programming password
		<u>AN-GWU*</u> <u>0#25*</u> <u>X..X*YR</u>	READING THE PAIRING CALL NUMBER X...X: programming password Y: table position, from 1 to 6
26	ENTERING A PRE-RECORDED NUMBER	<u>AN-GWU*</u> <u>0#26*</u> <u>X..X*Y*</u> <u>Z..Z*Z..Z#</u>	ENTERING THE ROUTING CALL NUMBER X...X: programming password Y: table position, from 1 to 6 Z...Z: telephone number
	DELETING A PRE-RECORDED NUMBER	<u>AN-GWU*</u> <u>0#26*</u> <u>X..X*Y#</u>	ERASING THE ROUTING CALL NUMBER X...X: programming password Y: table position, from 1 to 6
	DELETING ALL PRE-RECORDED NUMBERS	<u>AN-GWU*</u> <u>0#26*</u> <u>X..X#</u>	ERASING ALL ROUTING CALL NUMBERS X...X: programming password
	READING PRE-RECORDED NUMBERS	<u>AN-GWU*</u> <u>0#26*</u> <u>X..X*YR</u>	READING THE ROUTING CALL NUMBER X...X: programming password Y: table position, from 1 to 6
30	2G/3G/4G SIGNAL LEVEL MEASUREMENT (4)	<u>AN-GWU*</u> <u>0#30#</u>	Level from 0, 1 to 4 Answer (example) AN?GWU*0#30*3# => Signal of 3 out of 4

PROGRAMMATION PAR SMS



Code	Function	format	Descriptions / Informations
33	NETWORK TYPE SETTING	<u>AN-GWU*</u> <u>0#33*X#</u>	X : choice from 0 to 6 0 : 2G GSM 1 : 2G GSM / 3G UMTS 2 : 3G UMTS 3 : 4G LTE 4 : 3G UMTS / 4G LTE 5 : 2G GSM / 4G LTE 6 : 2G GSM / 3G UMTS / 4G LTE
	READING THE TYPE OF NETWORK	<u>AN-GWU*</u> <u>0#33R</u>	Answer (example) AN?GWU*0#33*6# => configured for 6
40	DEFINITION OF NOTIFICATION NUMBER	<u>AN-GWU*</u> <u>0#40*</u> <u>X..X*X..X#</u>	X...X: Designated phone number for SMS notification of battery status, failure/restoration of external power supply, mobile network and for SMS reading of SIM card expiration.
	DELETE NOTIFICATION NUMBER	<u>AN-GWU*</u> <u>0#40#</u>	Erase
	READ NOTIFICATION NUMBER	<u>AN-GWU*</u> <u>0#40R</u>	Reading of the telephone number assigned to the reception of notification SMS
42	DEFINITION OF THE TEL NUMBER. ANEP PROTOCOL	<u>AN-GWU*</u> <u>0#42*</u> <u>X..X*X..X#</u>	X...X: telephone number designated to receive the ANEP protocol
	READING OF THE TEL NUMBER. ANEP PROTOCOL	<u>AN-GWU*</u> <u>0#42R</u>	Reading of the telephone number designated to receive the ANEP protocol
44	ANEP PROTOCOL IDENTIFIER ENTRY	<u>AN-GWU*</u> <u>0#44*</u> <u>X..X*X..X#</u>	X...X: identification number of the BOX (8 digits), or other ANEP product
	READ ANEP PROTOCOL IDENTIFIER	<u>AN-GWU*</u> <u>0#44R</u>	Reading the ANEP product identification number (8 digits)
50	ACTIVATION OF THE BATTERY CHARGE LEVEL CONTROL (5)	<u>AN-GWU*</u> <u>0#50#</u>	Activation of the battery charge level control (of the P4GU gateway)

PROGRAMMING BY SMS



Code	Function	format	Descriptions / Informations
51	DISABLE BATTERY CHARGE LEVEL CONTROL	<u>AN-GWU*</u> <u>0#51#</u>	Disabling the battery charge level control (of the P4GU gateway)
52	THRESHOLD BATTERY (5)	<u>AN-GWU*</u> <u>0#5x#</u>	X: Choice of 0 to 1 0 = Alert enabled (default) 1 = Alert disabled
		<u>AN-GWU*</u> <u>0#52*x#</u>	X: Choice of 0 to 7 0 = 7 hour 1 = 6:30 a.m. 2 = 6:00 a.m. 3 = 5:30 a.m. 4 = 4 hour (default) 5 = 2.5 hours 6 = 1.5 hours 7 = 1:00 a.m. (Minimum number of operating hours, in backed up mode, guaranteed by the battery charge) Below this threshold, a notification SMS is sent.
5R	READING OF THE BATTERY CHARGE LEVEL CONTROL	<u>AN-GWU*</u> <u>0#5R</u>	Reading of the battery charge level control (from the P4GU gateway)
61	TELEPHONE LINE VOLTAGE	<u>AN-GWU*</u> <u>0#61*X#</u>	X: choice from 0 to 1 0 = 36 VDC 1 = 52 VDC
	Gateway reset required for validation 0#98#		
	TELEPHONE LINE VOLTAGE READING	<u>AN-GWU*</u> <u>0#61R</u>	Answer (example) AN?GWU*0#61*1# => Value of 1 (52V)
81	EXTERNAL POWER SUPPLY CONTROL ACTIVATION (6)	<u>AN-GWU*</u> <u>0#81*XXYY#</u>	Enabling External Power Control XX = minutes of power failure (01 to 99) YY = power restore minutes (01 to 99)
	DISABLE EXTERNAL POWER SUPPLY CONTROL (6)	<u>AN-GWU*</u> <u>0#81*0#</u>	Disabling the function
	READING OF THE CONTROL POWER SUPPLY EXTERNAL (6)	<u>AN-GWU*</u> <u>0#81R</u>	Reading the status of the power control Response (example) AN?GWU*0#81*0105# => Value of 0105 (default)

PROGRAMMING BY SMS



Code	Function	format	Descriptions / Informations
90	IDENTIFICATION TYPE OF GATEWAY (7)	<u>AN-GWU*</u> <u>0#90#</u>	2 sms : AN?GWU*0#904G-NET*209110501 Jun 29 2021 09:07:57 ELS61-E R2 REVISION 02.000 A-REVISION 01.000.02 35835101425588 ATC:4G MCC:208 MNC: 20 TAC: 79BC Cell: 7BCCE01 RSRP:-84 RSRQ:-7.5 POW ONH RM:NO#
91	READING BATTERY STATUS (8)	<u>AN-GWU*</u> <u>0#91#</u>	Answer (example) AN?GWU*0#91*x# X : Choice from 0 to 4 0 = Battery missing, not connected, damaged 1 = 1 hour 2 = 2 hours 3 = up to 7 hours 4 = more than 7 hours
97	REMOTE UPDATE	<u>AN-GWU*</u> <u>0#97#</u>	Updating the firmware of the remote gateway (DATA PACKAGE REQUIRED)
98	RESET (REBOOT) (9)	<u>AN-GWU*</u> <u>0#98#</u>	<u>Nota</u> : Resetting the gateway does not modify its programming
99	FACTORY RESET (10)	<u>AN-GWU*</u> <u>0#99#</u>	Return to default configurations
0002	READING MIN END OF SESSION	<u>AN-GWU*</u> <u>0#0002R</u>	Answer (exemple) AN?GWU*0#0002*01# X=0 et Y=1
0002	WRITING MIN END OF SESSION	<u>AN-GWU*</u> <u>0#002*XY#</u>	X=0 <se_expire> 1800 secondes X=1 <se_expire> 900 secondes Y=0 <min_se> 1800 secondes Y=1 <min_se> 900 secondes

Page 35

Page 36

Page 37

Page 37

PROGRAMMING BY SMS



Code	Function	format	Descriptions / Informations
0087	READ MODE URI	<u>AN-GWU*0#0087R</u>	Answer (example) AN?GWU*0#0087*1# X=1 SIP URI
0087	WRITING URI MODE	<u>AN-GWU*0#0087*X#</u>	X=1 SIP URI X=2 TEL URI
C F G	READING APN SELECTED	<u>AN-GWU*0#RCRFRG</u>	Answer (example) AN?GWU*0#C*objcobytel.com#F#G#
C F G	WRITING APN SELECTED	<u>AN-GWU*0#Cx#Fy#Gz#</u>	x: Operator APN (APN = Operator Network Access Point) y: APN user (optional) z: APN password (optional) ORANGE -> AN-GWU*0#Corange#Forange#Gorange# BOUYGUES -> AN-GWU*0#Cmmsbouygtel.com#F#G# BOUYGUES -> AN-GWU*0#Cobjcobytel#F#G# -> (VoLTE) SFR -> AN-GWU*0#Csl2sfr#F#G# -> (VoLTE) example writing (reset APN) AN-GWU*0#C#
N	WRITING IP TYPE CODE	<u>AN-GWU*0#N*1*X*#</u>	X: choice of 1 to 3 1 = IPv4 (default) 2 = IPv4v6 3 = IPv6
O	READING NETWORK APN	<u>AN-GWU*0#RO</u>	Answer (example) AN?GWU*0#O*apn#

(1)(2) GAIN SETTINGS

CODE CODE

10	11	See programming tables by PHONE or SMS
-----------	-----------	--

These settings are used to adjust the gain of transmission and reception.



WARNING

The values saved by default are the optimal ones, modify them only if it is really necessary.

Transmission

By default :

4
0db

- Enter a value (1 ~ 7) according to the following table:

1	2	3	4	5	6	7
-6dB	-4dB	-2dB	0dB	2dB	4dB	8dB

Reception

By default :

3
-8db

- Enter a value (1 ~ 5) according to the following table:

1	2	3	4	5
-12dB	-10dB	-8dB	-5dB	-2dB

(3) AUTOMATIC CONVERTER OF THE TELEPHONE NUMBER DIALED (ROUTING AND COUPLING)

CODE CODE

25	26	See programming tables by PHONE or SMS
-----------	-----------	--

If the function is activated, the gateway, instead of calling the telephone number dialed from the connected telephone (BOX-TA remote alarm, or other device telephone), forwards the call to a previously defined number.

It is possible to predefine up to 6 telephone numbers to call, each one of which can be combined, through programming and/or activating the function. Each of them can be associated, by programming and/or learning automatic, to a dialed number.

When the dialed number is not associated with any predefined number, the call will be automatically forwarded to the first preset phone number.

Nota : To activate the "Automatic Converter" Service, simply preselect a phone number

To deactivate this service, all phone numbers must be deleted. preselected phone.

Example: Table of presets

Emplacement	Phone number selected (code 25)	Phone number predefined (code 26)
1	0123456789	0601020304
2	0123456790	0601020305
3	0123456791	0601020306
4	0123456792	0601020307
5	0123456793	0601020308
6	0123456794	0601020309

By selecting the phone number 0123456789, the gateway will make a call to 0601020304

By selecting the phone number 0123456790, the gateway will make a call to 0601020305 etc...

When you select a number that is not in the "Selected phone number" column, the gateway sends a call to the first phone number in the "Predefined phone number" column.

Automatic phone number matching

- Enter the number to call in a slot in the table using the programming code 26.
- Enter the number dialed, to be associated, in the same location of the table using the programming code 25.

Automatic learning procedure

The automatic learning procedure makes it possible to automatically match each predefined number with the numbers dialed by the telephone connected (BOX remote alarm or other telephone device) with the gateway.

- Enter the number to call using programming code 26.
- Dial a telephone number with the telephone connected (BOX remote alarm or other telephone device) to the gateway.

The gateway will check if the number already matches a predefined phone number. If so, it sends a call to the predefined number.

If not, it will match the dialed number to the first available predefined number and make a call to that number.

If there are no predefined numbers available, but it is still possible to make associations, the dialed number will be automatically associated with the first predefined number.

If the 6 possible associations have been made, the call will be sent to the first predefined number.

An SMS containing the dialed number and the preselected number is sent to the administrator's number (if provided) when creating any new association.

An SMS is also sent each time a different selection of the 6 presets is made.

(4) SIGNAL LEVEL MEASUREMENT

CODE

30

See programming tables by [PHONE](#) or [SMS](#)

This procedure allows you to check the level of the 2G (GSM), 3G (UMTS) or 4G (LTE) signal via your telephone, or by SMS.

By telephone :

- Pick up the handset and dial ****30#**
- Wait for signal reading.

The gateway will send a number of short tones corresponding to the signal level:

Tones	Quality
No lack of network	No signal / No network
1 Tone	Low (not functional)
2 Tone	Medium (random operation)
3 Tone	good (recommended level)
4 Tone	high

As the signal may be subject to variations, we recommend repeating the code ****30#**, 2 or 3 times at intervals of a few seconds, in order to obtain a reliable signal.

Nota : in case of weak or average signal, we recommend to install the gateway in a different area with better signal.

Nota : if you receive the "no signal" tone, it means that the gateway was not registered correctly by the network operator.
We recommend that you try again after a few moments, and if not, check that the SIM card is working properly.

(5) **BATTERY ALERT**

CHECKING THE CHARGE LEVEL OF THE BATTERY

CODE CODE

50	52	See programming tables by PHONE or SMS
----	----	--

If the low battery check is activated, the P4GU VoLTE checks the charge level of the latter at all times..

When the charge level drops below the level necessary to guarantee 4 hours of autonomy, in standby, a warning message is sent to a pre-recorded number.

This information is transmitted either by SMS (by default) or to ANEPCenter by voice (DTMF).

See “Signaling the absence of external power supply or the level of battery charge via ANEPCenter”.

Transmission by SMS (default):

The device sends a single warning SMS.

A new warning SMS is sent only if the state of charge rises and then falls below the threshold necessary to guarantee 4 hours of autonomy, on standby.

The text of the message sent is as follows: "*Battery discharged*"

The internal backup batteries guarantee 8 hours of operation in standby and 1 hour in conversation.

On the other hand, when the remote alarm line is seized, a discontinuous dial tone is generated. This tone allows ANEP BOX-TA, TA+, TX or TX+, S-BOX, BOX-CAN, E-BOX and BOX-PARK equipment to generate a "*GSM battery fault*".

(6) EXTERNAL POWER FAILURE CHECK

CODE

81	See programming tables by PHONE or SMS
-----------	--

If the external power supply failure check is activated, the gateway constantly checks the external power supply (230Vac or 12Vdc)

If the external power grid failure lasts longer than the preset time interval, a notification SMS is sent with the following text message:

«External Power Failure»

If the external power supply is restored for a time interval equal to the predefined threshold, a new SMS is sent with the following text message:

«External power restored».

(7) READING ADVANCED

GATEWAY PARAMETERS

CODE

90	See programming tables by SMS (only)
-----------	--

This procedure allows you to check the advanced settings of the P4GU VoLTE device and GSM gateway.

Send the following SMS to **P4GU : AN-GWU*xxx#90#**

or :

AN-GWU Beginning of the programming chain

***xxx#** password string (default xxx = 0)

P4GU VoLTE Will send one or two text messages to the number that sent the request, with the following data:

Values (the values shown are for illustrative purposes)	Signification
AN?GWU*XXX#90P4GU*	start of string
211000501 Mar 19 2021 08:52:32	P4GU software version
ELS61-E R2 02.000 ARN 01.000.05	Radio module data
359206065733230#	Code IMEI
4G	ACT: Access Technology
208	MCC Code (Country Code)
20	MNC Code (Operator Code)
7537	TAC (Tracking Area Identifier) LAC (Location Area Identifier)
7A69401	CELL (cell ID)
-108	RSRP (Received Reference Signal Power)
-15	RSRQ (Reference signal reception quality)
POW or BATT	POW or BAT POW (External Power Present) BATT (External Power Supply Absence)
ONH or OFH	ONH (Line in use) OFH (Line available)

(8) BATTERY STATUS READING

CODE

91	See programming tables by PHONE or SMS
-----------	--

If the battery charge level control is activated, you can interrogate the P4GU VoLTE device for battery status.

This procedure allows you to check the battery status through your telephone, or by return text.

The gateway sends a number of short tones corresponding to the number guaranteed operating hours in standby mode:

Tones	Standby hours
No dial tone	Battery missing or damaged
1 Tone	1 hour
2 Tone	2 hour
3 Tone	until 7 a.m.
4 Tone	more than 7 hours

(9) REBOOT

CODE

98

See programming tables by [PHONE](#) or [SMS](#)

It is possible, at any time, by telephone or SMS to restart the P4GU VoLTE without turning off the power.

Note: Restarting the P4GU VoLTE does not change any programming.

(10) RESET TO FACTORY SETTINGS

It is possible to return, at any time, to the factory settings using the code:

CODE

99

See programming tables by [PHONE](#) or [SMS](#)

Factory settings:

Roaming	enabled
Checking the battery charge level	enabled / 4h
Control of the absence of the electrical network	disabled
Transmitter gain	0dB
receiver gain	-8dB

Identification of the 2G or 4G gateway model:

By SMS by sending the code 90 (ref page 27)

Feedback message for **2G** version : : **AN?GWU*0#90PGU....**

Feedback message for **4G** version : **AN?GWU*0#90P4GU...**

SERVICES

Incoming calls

Allows you to answer incoming calls.

When receiving a phone call, the line status LED (white) will briefly flash 4 times every 4 seconds as described in chapter "**Signals**" (see page 39) and the telephone will ring. Décrochez le combiné pour répondre à l'appel.

The line status LED (white) and the device status LED (red) will light up, and communication with the caller will be established.

Outgoing calls

Allows you to dial a number on the 2G / 3G / 4G network.

The fallback feature is a feature that allows phones covered by the 4G network to fall back on the 2G/3G network to be able to make a call.

If the gateway is connected to a PABX (autocom), please refer to the switchboard manual.

If the gateway is connected to a telephone :

- Pick up the handset

The line status LED (white) lights up and the dial tone is heard.

- Dial the phone number to call.

When the called party answers, the device status LED (red) lights up.

Nota : once you have dialed the number, you can either press # to send the number immediately, or you can wait for the call to be automatically transferred once that the call will be automatically transferred once the time of dialing between digits will have elapsed (default 5 seconds)

Nota : if you receive the dissuasion tone when picking up the handset the handset, check if the signal is present and make sure that the SIM card is working properly.

SIGNALS

TONE

Invitation to Dial (Continuous Tone) :



Indicates that the device is ready to receive the selection.

Deterrence :

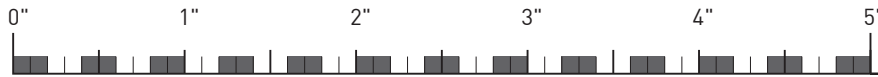

Indicates that there is a delay in programming selection, that the caller has hung up or an unauthorized access has been made.

Busy :

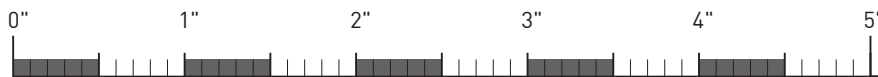

Indicates that the called party is busy.

Confirm :



Indicates that the programming performed has been accepted.

Error :



Indicates that the programming performed has not been accepted.

Signal quality:



Indicates that the signal level is low.

Signal quality:



Indicates that the signal level is medium.

Signal quality:



Indicates that the signal level is good.

Signal quality :

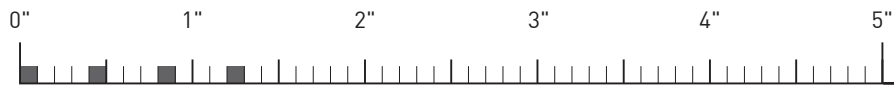

Indicates that the signal level is high.

Signal quality:

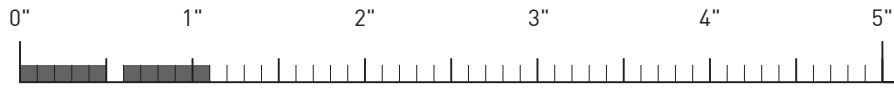

Indicates the absence of the signal.

CALL SIGNALING

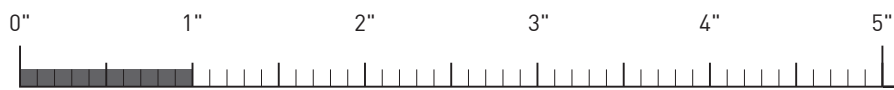

Indicates the arrival of an incoming call.

LED



LED (GREEN) 2G, 3G, 4G network strength (without VoLTE)

Indicates no signal.

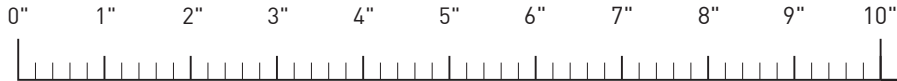

Indicates that the signal level is low.



Indicates that the signal level is medium.



Indicates that the signal level is good.



Indicates that the signal level is high.



LED (GREEN) 4G VoLTE network strength

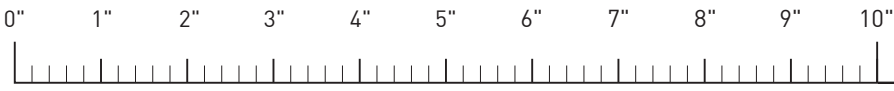

Indicates no signal.

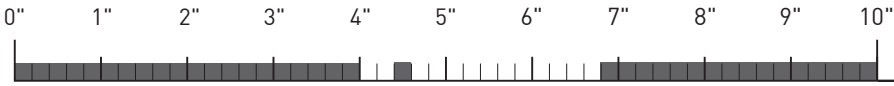

Indicates that the signal level is low.

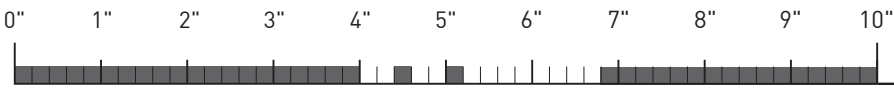

Indicates that the signal level is medium.

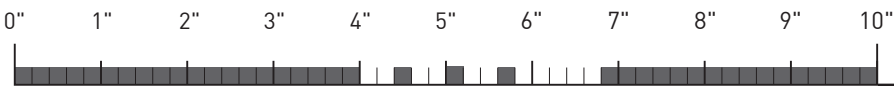

Indicates that the signal level is good.

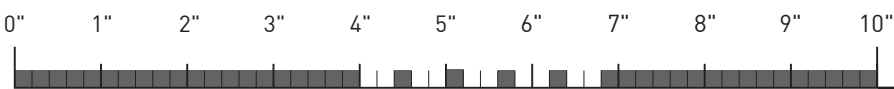

Indicates that the signal level is high.

LED (RED) device Status



1

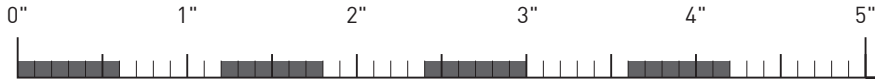

When lit, it indicates that a registration of the device to the network is in progress, then it indicates that the device is not correctly registered to the network, that the SIM card is protected by the PIN or other problems.

2

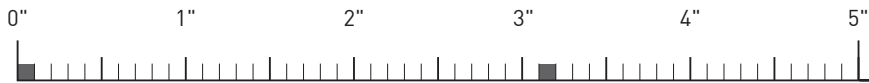

Indicates that the device is successfully registered to the network.



Indicates a voice connection in progress.

LED (WHITE) line status



Indicates that the line is busy.



Indicates that the line is not picked up.

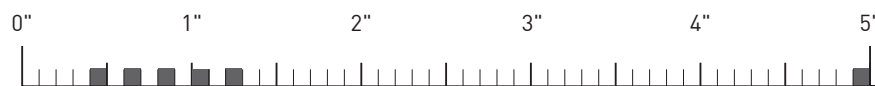

Indicates an incoming call.

LED (BLUE) power status



Indicates power is on and battery is fully charged.

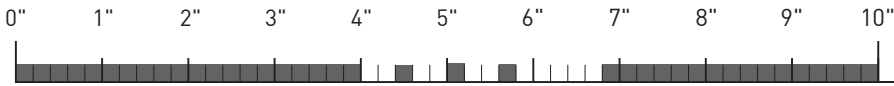

Indicates power is on and battery charge is high.

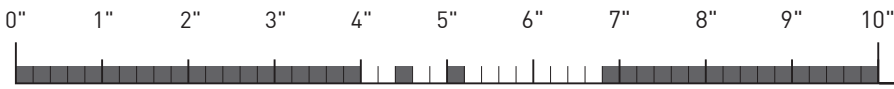

Indicates power is on and battery charge is medium.

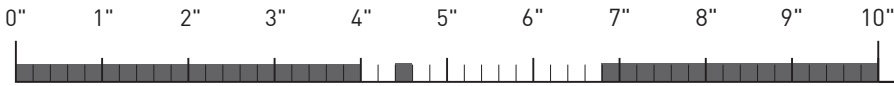

Indicates power is on and battery charge is low.



Indicates that the power is connected and the battery is damaged or is not connected.

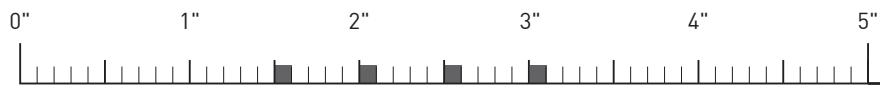

Indicates that the power is not connected and the battery guarantees more than 7 hours of standby operation.

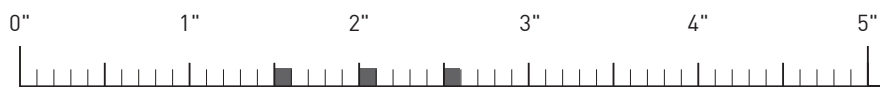

Indicates that the power is not connected and the battery guarantees up to 7 hours of standby operation.

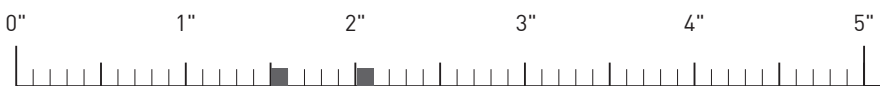

Indicates that the power is not connected and the battery guarantees 2 hours of standby operation.



Indicates that the power is not connected and the battery guarantees 1 hour of standby operation.

PROBLEM RESOLUTION

This chapter recalls the most common problems that can occur. Before calling technical assistance, carry out these simple checks.

Condition	Causes	Solutions
All LEDs are off	P4GU not powered	Check Power
The red LED flashes (as visualized on 1 page 42)	The SIM card is not inserted or incorrectly inserted	Correctly insert the SIM card in its lodging
	Protected SIM card by PIN code	Remove PIN code with mobile phone
	Expired SIM card or damaged	Check operation of the SIM card with a mobile phone
	SIM card not compatible	Use a GSM / UMTS / LTE SIM card
		Perform a control test with the SIM card of another operator
	Antenna not connected or cable damaged	Check the antenna connection and the integrity of the cable
	Lack of mobile network coverage	Check for the presence of mobile network coverage with a mobile phone
	Supply insufficient	check power supply
	Generic problem software	Switch off and on again the P4GU
The red LED flashes (as visualized on 2 page 42) but the green one is off	Mobile network signal level too low to guarantee the call	Move the P4GU and the antenna to a position where the signal will be better

NOTES

NOTES

ANEP applies a method of continuous development, therefore, ANEP reserves the right to make changes and improvements to any product described in this document, without notice.

ANEP cannot under any circumstances be held liable for any loss of data, as well as any particular damage or incident, resulting from poor implementation or non-compliant use of the product.

The contents of this document are provided “as is”. No warranty of any form, express or implied, is made as to the accuracy, reliability, or content of the document. ANEP reserves the right to revise this document or withdraw it at any time without notice.

WARRANTY

This product is guaranteed for **3 years** from the date of invoicing of the product, with the exception of batteries and cells which are guaranteed for **6 months**.

However, this guarantee does not apply in the event of:

- Use that does not comply with the instructions in this manual.
- Deterioration from a cause external to the product (act of vandalism, fire, flood, storm, overvoltage...).
- Installation carried out by an unqualified installer not approved by ANEP.
- Modifications or repairs carried out by entities not approved by ANEP.
- Opening of the product by a non-ANEP approved person.



IMPORTANT

Particular care and rigor must be taken in the cabling and connection, in order to obtain the best sound results and optimal reliability of the product.

The equipment must be connected, installed and programmed according to the rules of the trade.



THE AFTER SALES SERVICE IS PROVIDED BY

SAVTEL

4 bis rue de Paris 94470 Boissy-Saint-Léger

+33 1 45 98 34 44



Website : www.anepstore.com