

Installation of OIL BUFFER OBC10B

This paragraph shows useful information for the installation of oil buffer Hydronic Lift model **OBC10B**.



NOTE: Remove the plastic film or the plastic bag that protect the ram during the shipment before installing the buffer.

1. BUFFER LIFTING

Use a textile rope for lifting so that the buffer surface does not get damaged.

Use the strap by hooking it under the head stem of the buffer.

NOTE: Buffers are shipped in vertical position and filled with oil. During transporting and handling, the oil buffers must keep in vertical position to avoid oil leakage.

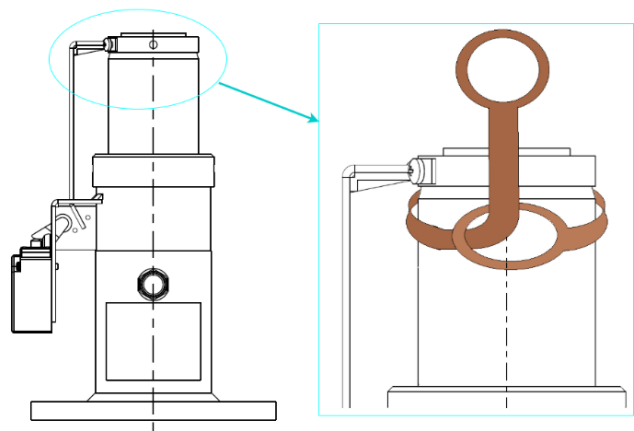

2. WORKING CONDITIONS

Temperature: -5/45°C; (for different temperature range contact to Hydronic Lift)

Humidity: less than 95%

Environmental without explosion risk, no risk of corroding metal and destroying insulation.

Pit is clean and no ponding.

3. LIFETIME

The life of the unit is assessed only on “condition monitoring” practice.

As an example, the replacement of the unit will be made if:

- During planned checks, if presence of corroded metal parts are noted.
- Following occasional events that may have compromised the integrity and functionality of some components of the hydraulic damper, such as flooding of the pit or fire.

4. BUFFER INSTALLATION

Base plate fastening

Nr. 4 screw M 12 o
 Nr. 4 anchor bolt M 12 x 105 for direct fastening to the pit

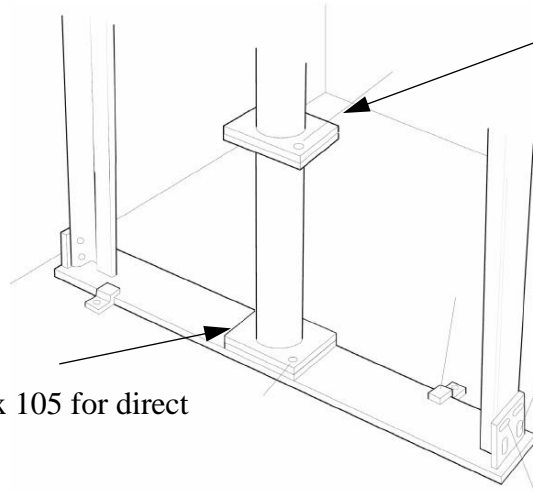

With buffer extension
 Nr. 4 screw M 12

Support

The supports are installed according to the following table and drawing.

The clearance between the support(1) and the car must be 100...150 mm when the car is standing on the compressed buffer. The buffer and the extension are fastened with steel clamps to the support

CL	HE	BB	support (1)	support (2)
< 2000	-	< 2000	-	-
≥ 2000	-	≥ 2000	X	-
< 2000	< 2000	≥ 2000	X	-
≥ 2000	< 200	< 4000	X	-
< 2000	≥ 2000	< 4000	-	X
≥ 2000	≥ 2000	≥ 4000	X	X
< 2000	≥ 2000	≥ 4000	X	X

*Dimensions in [mm]

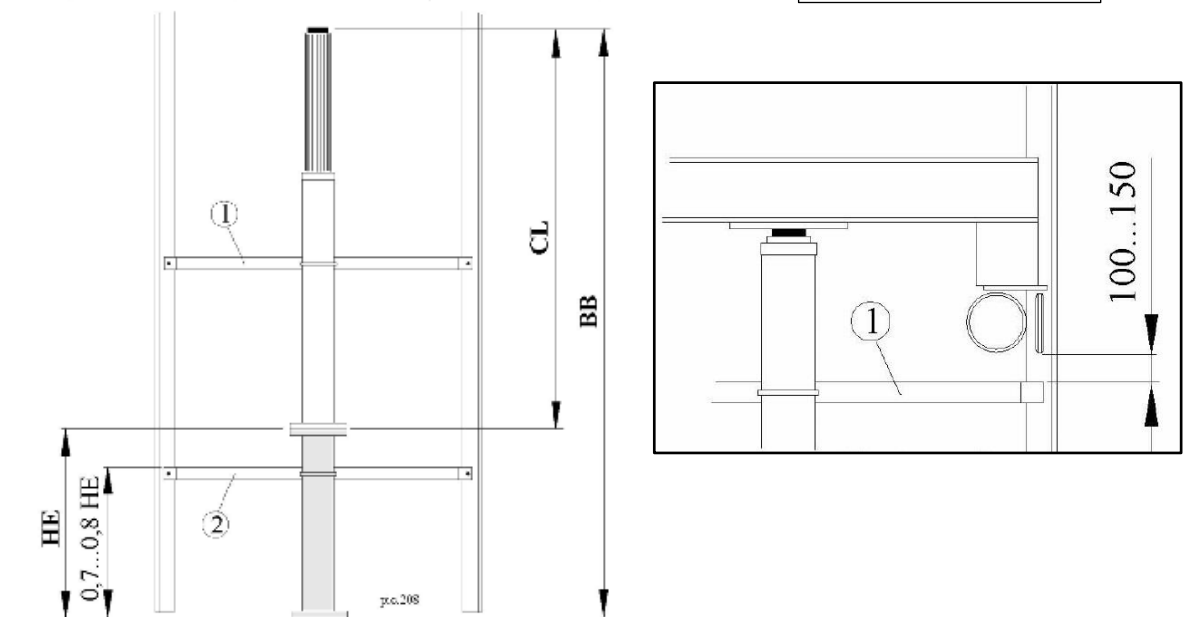

Buffer alignment

Check that the buffer is plumb.

- Check that the buffer is fix in a correct vertical position with a spirit level (bubble level).



Impact area

The contact between buffer and car frame must happen between rubber pad of buffer and a flat metal surface of car frame. This metallic surface is referred to a load-bearing component of car frame.

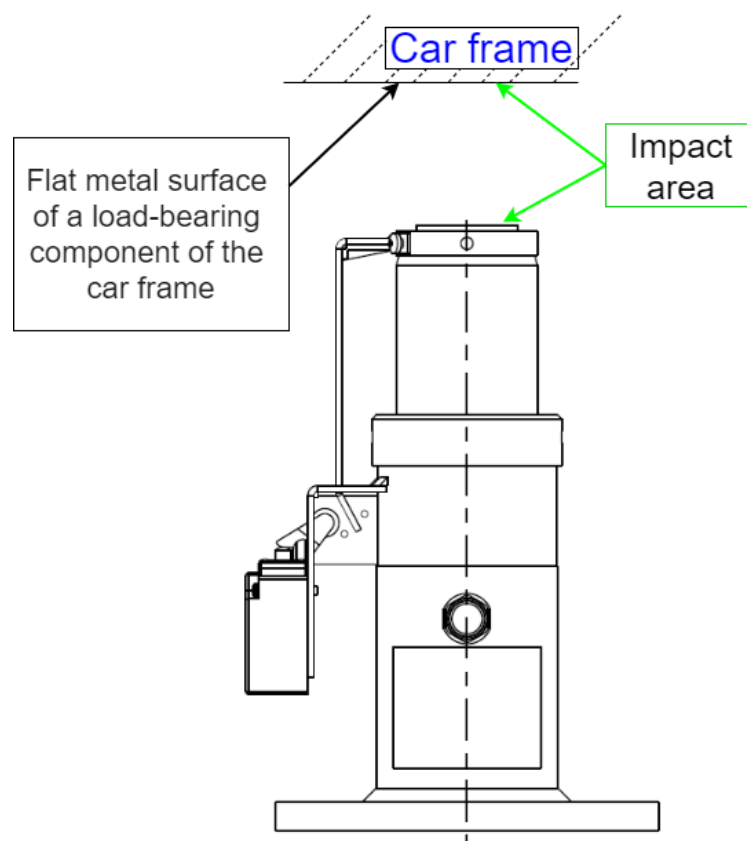

5. CHECKS BEFORE PUTTING INTO SERVICE: CHECK OIL LEVEL



Before putting into service the oil buffer, check the oil level with the following steps:

1. Fix the buffer in a vertical position and look the transparent oil level indicator for oil level checking. The oil level must be present inside the transparent cap.

ATTENTION: the oil level check must be performed after at least 10 minutes in which the buffer is released in a quiet and in vertical extended position and without further additions or drains of oil.

If you do not see the oil inside the transparent cap, the oil level is too low and an oil addition is necessary.

If the transparent cap is complete filled with oil, the oil level is too high and you must remove some oil.

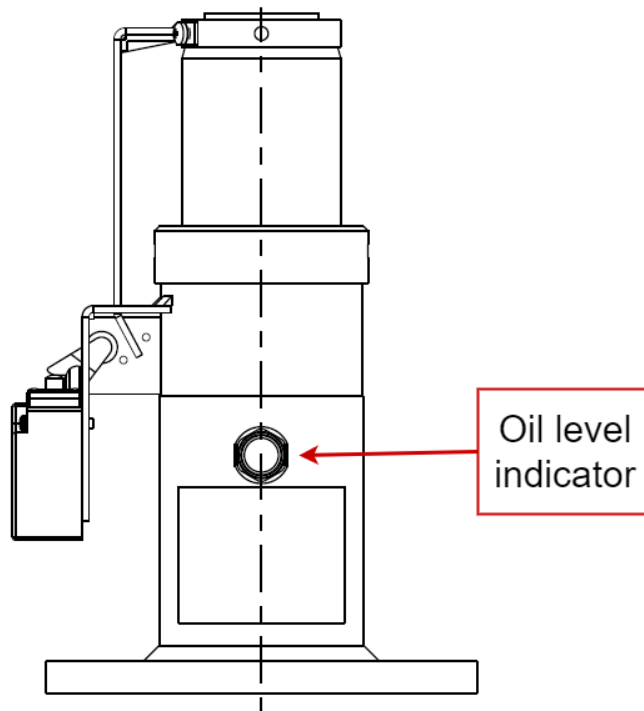

During functional test at the rated buffer speed, is allowed a small oil leakage from air vent holes. Always check the oil level after an impact at nominal speed.

Buffer is a safety component that prevents damage during an impact at the rated working condition of lift.

If the oil buffer is compressed during installation or maintenance, it is recommended to allow adequate time (10 minutes) to elapse before performing a further compression.

6. OIL FILLING AND DRAIN, OIL BUFFER OBC10B

Use mineral oil type: ISO VG GRADE 46, VI 104 min.

Buffer OBC10B is already filled with oil.

In the event that the shock absorbers must be filled, topped up or discharged with oil, proceed as follows.

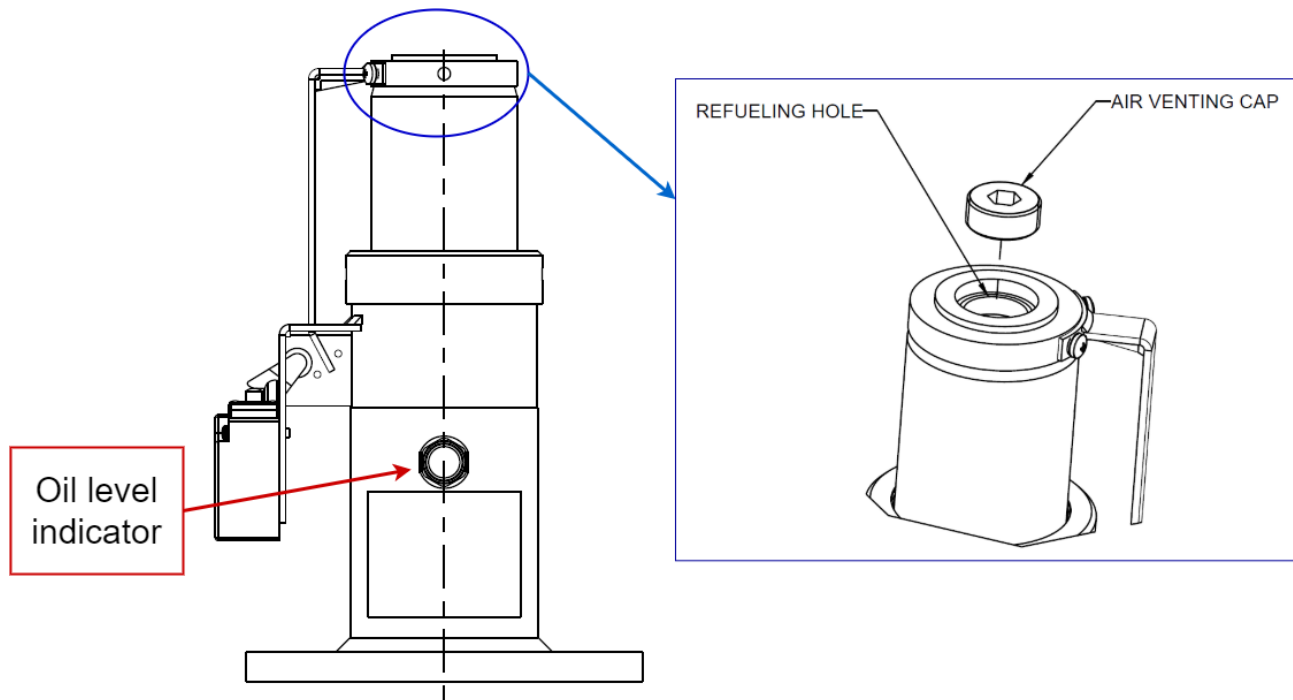

Complete filling of buffer:

- Place the buffer in a safe position, take care handling oil.
- Remove the air venting cap located in the center of the stem head.
- Check that the oil level indicator is closed.
- Insert the oil in the right quantity from the head of the stem trough the refueling hole (for oil quantity, see table in the catalog or identification plate on the cylinder of buffer).
- Wait at least 10 minutes.
- Check the level through the appropriate transparent indicator.
- If necessary, add again some oil until the correct oil level or let excess oil drain from the hole of oil indicator (you should remove the oil level indicator for few seconds).
- Reposition the air venting cap in the stem head and check the correct fixing of oil indicator.

Topping up oil:

- Place the buffer in a safe position, take care handling oil.
- Remove the air venting cap located in the center of the stem head.
- Check that the oil level indicator is closed.
- Fill in a little oil quantity at a time.
- Wait a few minutes.
- Check the oil level.
- Repeat the cycle until the oil is at the correct level.
- Once the oil has been leveled, fix the air venting cap on the stem head.

Oil drain:

- Make sure that the oil level is over than the maximum level even after the buffer has been at least 10 minutes in quiet and in extended vertical position.
- Place the buffer in a safe position, take care handling oil.
- Remove the oil indicator, the oil will start to leak.
- Wait a few moments and fix again the oil indicator in its seat.
- Check the oil level.
- Repeat the operation until the oil level is correct: the oil level must be visible inside the transparent part of oil level indicator.
- Check the correct fixing of oil indicator.