

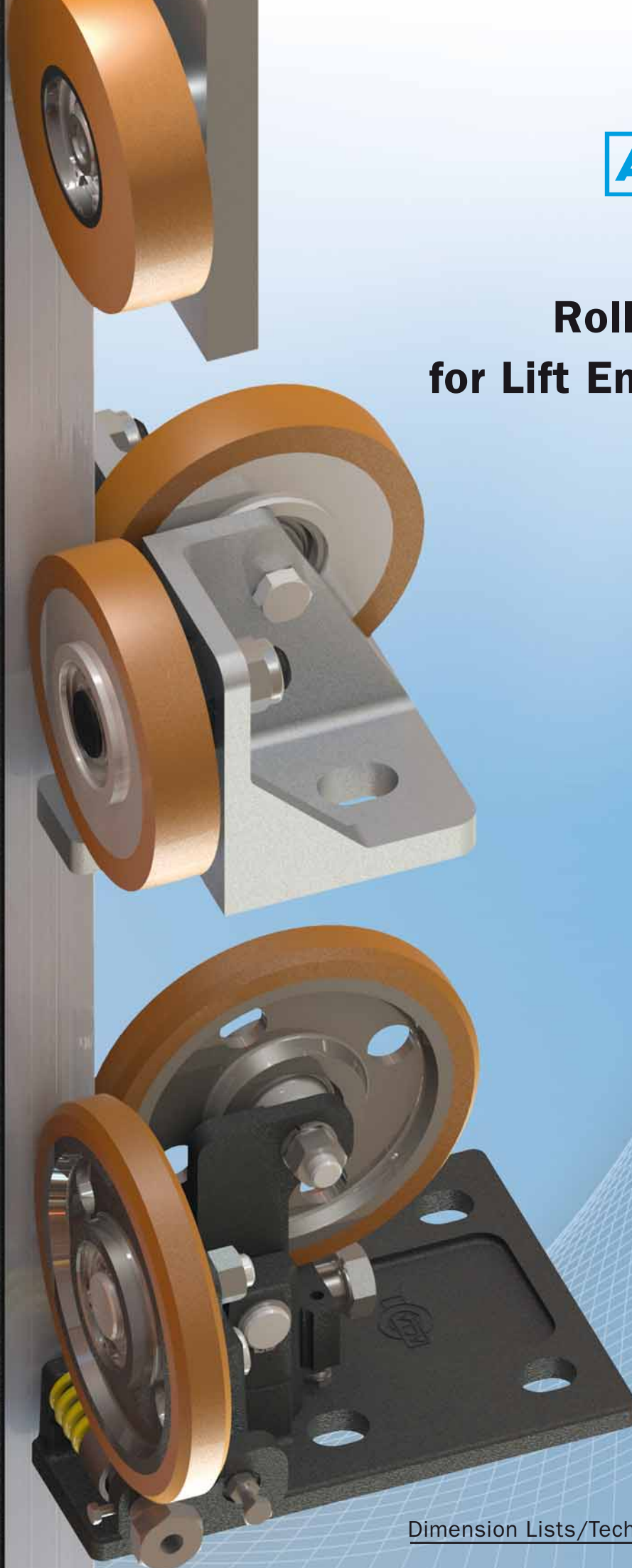

Roller Guides for Lift Engineering



Contents		Page
Practicable Roller Guides for Lift Engineering		3
Roller Guide AR 0.1	Roller Guide AR 0	4
Roller Guide AR 1	Roller Guide AR 1B	5
Roller Guide AR 3	Angled Roller Guide ARW 2	8
Spring loaded Roller Guide AR 1F	Spring loaded Roller Guide AR 3F	9
Roller Sliding Guide HSM RG	Roller Sliding Guide HSML RG	11

ACLA-Roller Guides are distinguished by a thought-out design

The ACLA-RollerGuide program consisting of many roller guides and roller sliding guides is designed for high-speed electric and hydraulic lifts.

With the roller guides the construction principle of of eccentrically adjustable king pins and oblong holes enable a correct adaption to the existing rail. Depending on type of roller guide an infinitely variable adjustment to rail widths from 4 to 36 mm is possible in an easy way by means of a fixed spanner or socket wrench.

The base supports of special alloy and steel used assure an excellent stability of the complete roller guide units.

Exact dimensioning of the rollers used

The experience of ACLA-WERKE in lift engineering for many years and the know-how as manufacturer of high-quality polyurethane elastomers enable our technicians to achieve an exact dimensioning of the rollers used for the individual application.

In combination with the choice of the appropriate polyurethane elastomer the ACLA rollers proved successful in roller guide units with excellent load values on a worldwide scale.

Rollers of ACLATHAN®

The premounted rollers of the high-quality polyurethane elastomer ACLATHAN for the lift industry offer the following advantages for the application:

- low rolling resistance
- high loading capacity
- excellent abrasion and wear resistance
- low oscillation on account of high concentricity
- silent running
- maintenance-free
- oil-resistant
- minimum compression set (flattening) after temporary standstill



type: AR 0.1

ACLA-Roller Guides are deliverable with roller dias. from 40 to 200 mm



type: AR 3

Roller Guide AR 0.1

∅ 40 x 15

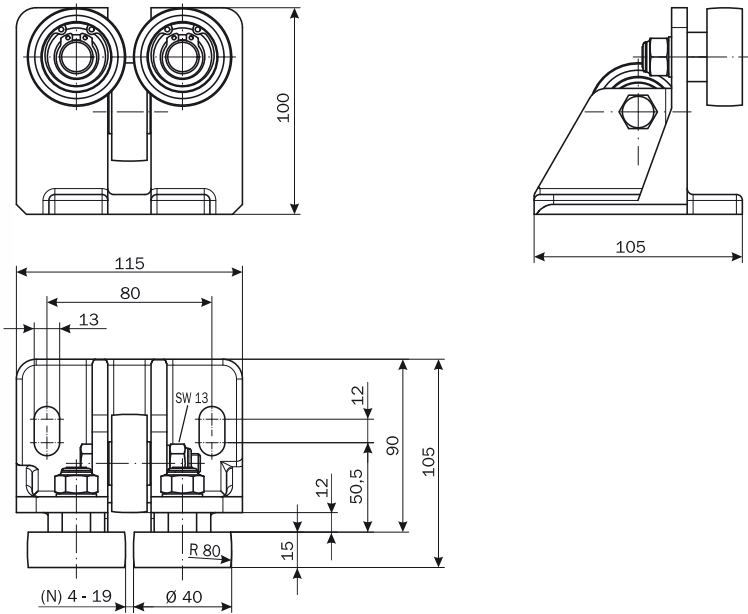
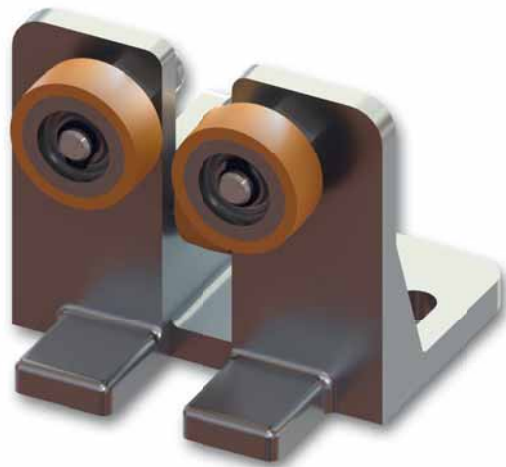

Design Details

- Infinitely adjustable to rail width from **4 to 19 mm** in no time. A gap between roller and rail of 0,1 to 0,5 mm has to be considered
- King pins adjustable in the oblong holes, SW 19
- The breaking limit of the base support is ca. 10 kN

art. no.	rollers ∅ D x b	complete weight ca. kg	*max. load [N] per roller with v nominal [m/s]		
			0,63	1,0	2,5
142294.04	40 x 15	1,15	630	600	570

*Information as to load: The load of the central roller decreases depending on the relation between rails and roller width.

Roller Guide AR 1

∅ 80 x 25 to ∅ 125 x 25

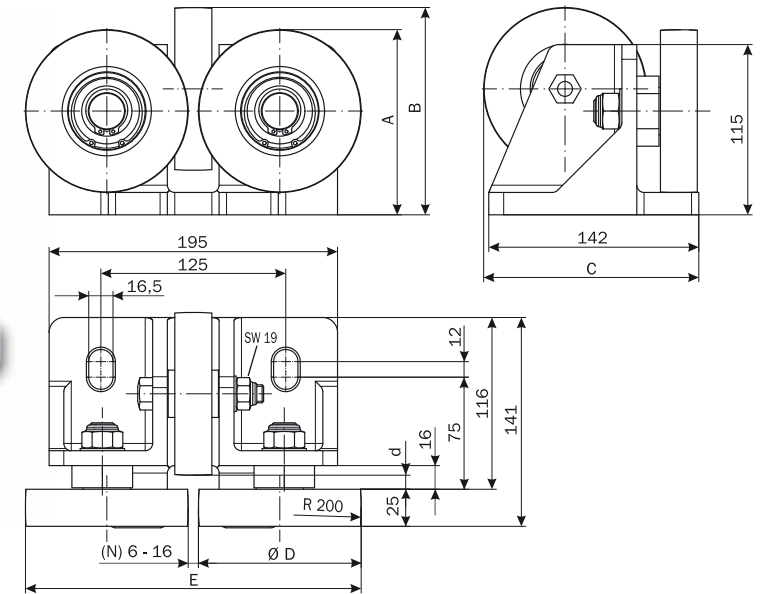

Design Details

- Infinitely adjustable to rail width from **6 to 16 mm** in no time. A gap between roller and rail of 0,1 to 0,5 mm has to be considered
- Excentrically adjustable king pins, SW 41
- The breaking limit of the base support is ca. 40 kN

art. no.	rollers ∅ D x b	no. of ball bearings	complete weight ca. kg	*max. load [N] per roller with v nominal [m/s]			mounting dimensions				
				0,63	1,0	2,5	A	B	C	d	E
141 895.04	80 x 25	1	3,6	1.830	1.790	1.480	max. 103	130	110	4	max. 177
141 896.04	100 x 25	2	5,1	2.360	2.310	1.910	max. 123	135	130	4	max. 217
141 897.04	125 x 25	2	7,1	3.120	2.980	2.570	max. 149	146	153	2	max. 267

*Information as to load: The load of the central roller decreases depending on the relation between rails and roller width.

Roller Guide AR 0

∅ 50 x 18 to ∅ 70 x 18

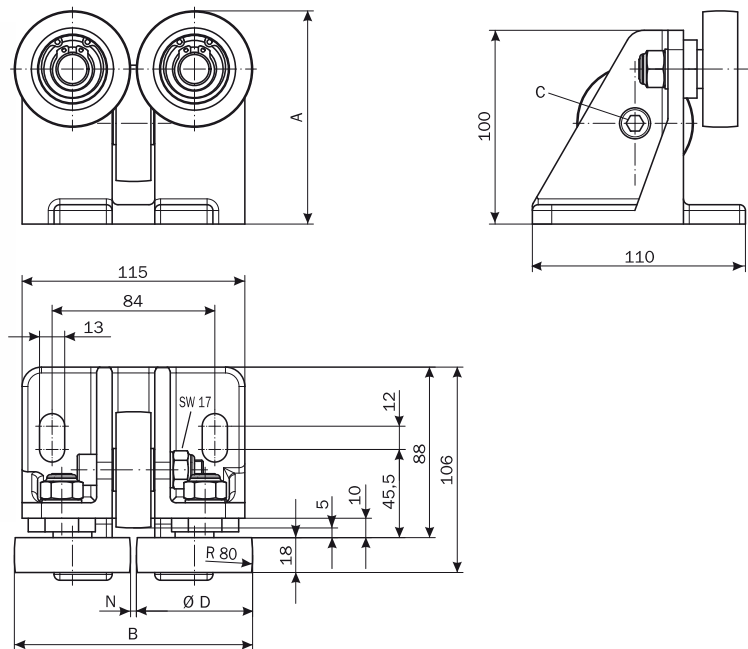
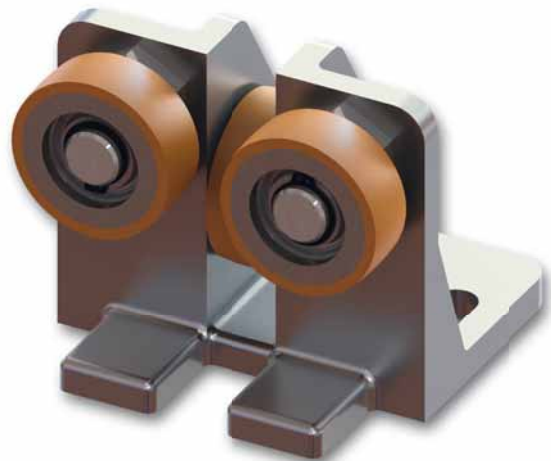

Design Details

- Infinitely adjustable to rail width from **5 to 25 mm** in no time. A gap between roller and rail of 0,1 to 0,5 mm has to be considered
- Excentrically adjustable king pins, SW 30
- The breaking limit of the base support is ca. 30 kN

art. no.	rollers ∅ D x b	complete weight ca. kg	*max. load [N] per roller with v nominal [m/s]			mounting dimensions		
			0,63	1,0	2,5	A	B	N
142042.04	50 x 18	1,3	1.000	960	900	max. 110,5	max. 126	5 - 25
142 043.04	60 x 18	1,35	1.200	1.100	1.050	max. 115,5	max. 141	5 - 20
142 044.04	70 x 18	1,42	1.300	1.250	1.200	max. 120,5	max. 161	5 - 20

*Information as to load: The load of the central roller decreases depending on the relation between rails and roller width.

Roller Guide AR 1B

∅ 125 x 30 side rollers
∅ 120 x 30 central roller

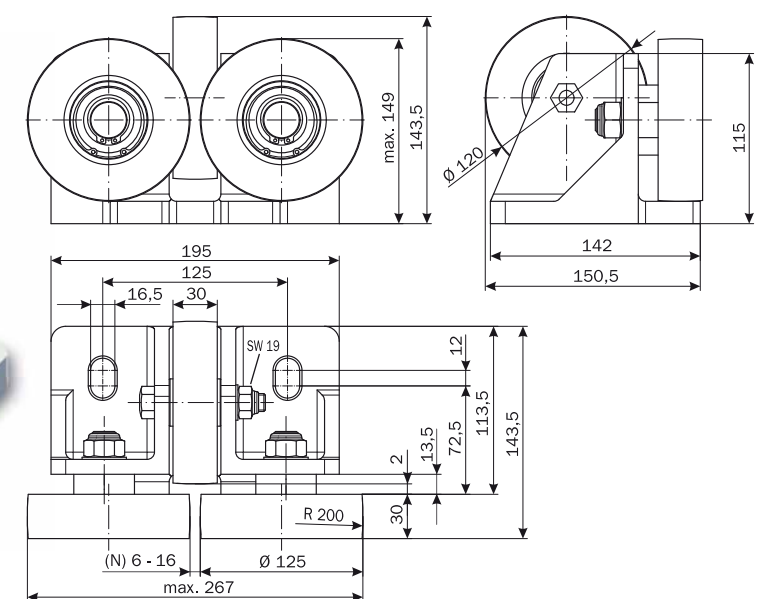
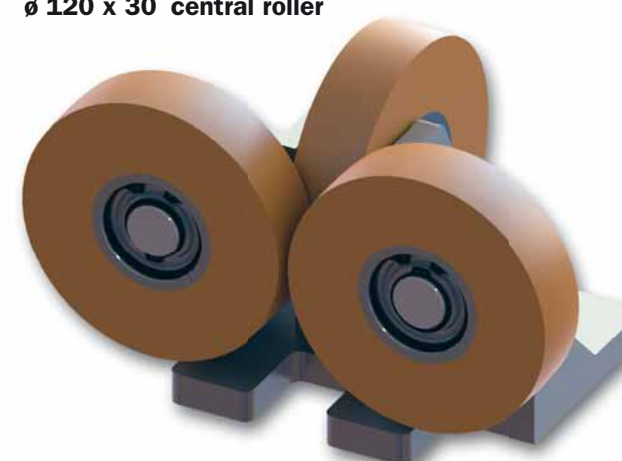

Design Details

- Infinitely adjustable to rail width from **6 to 16 mm** in no time. A gap between roller and rail of 0,1 to 0,5 mm has to be considered
- Excentrically adjustable king pins, SW 41
- The breaking limit of the base support is ca. 40 kN

art. no.	rollers ∅ D x b	no. of ball bearings	complete weight ca. kg	*max. load [N] per roller with v nominal [m/s]		
				0,63	1,0	2,5
142621.04	125 x 30 (2 x side roller) 120 x 30 (1 x central roller)	1	4,5	3.300	3.100	2.800
		1		2.790	2.730	2.330

*Information as to load: The load of the central roller decreases depending on the relation between rails and roller width.

**ACLA roller guides:
well conceived construction to the detail**

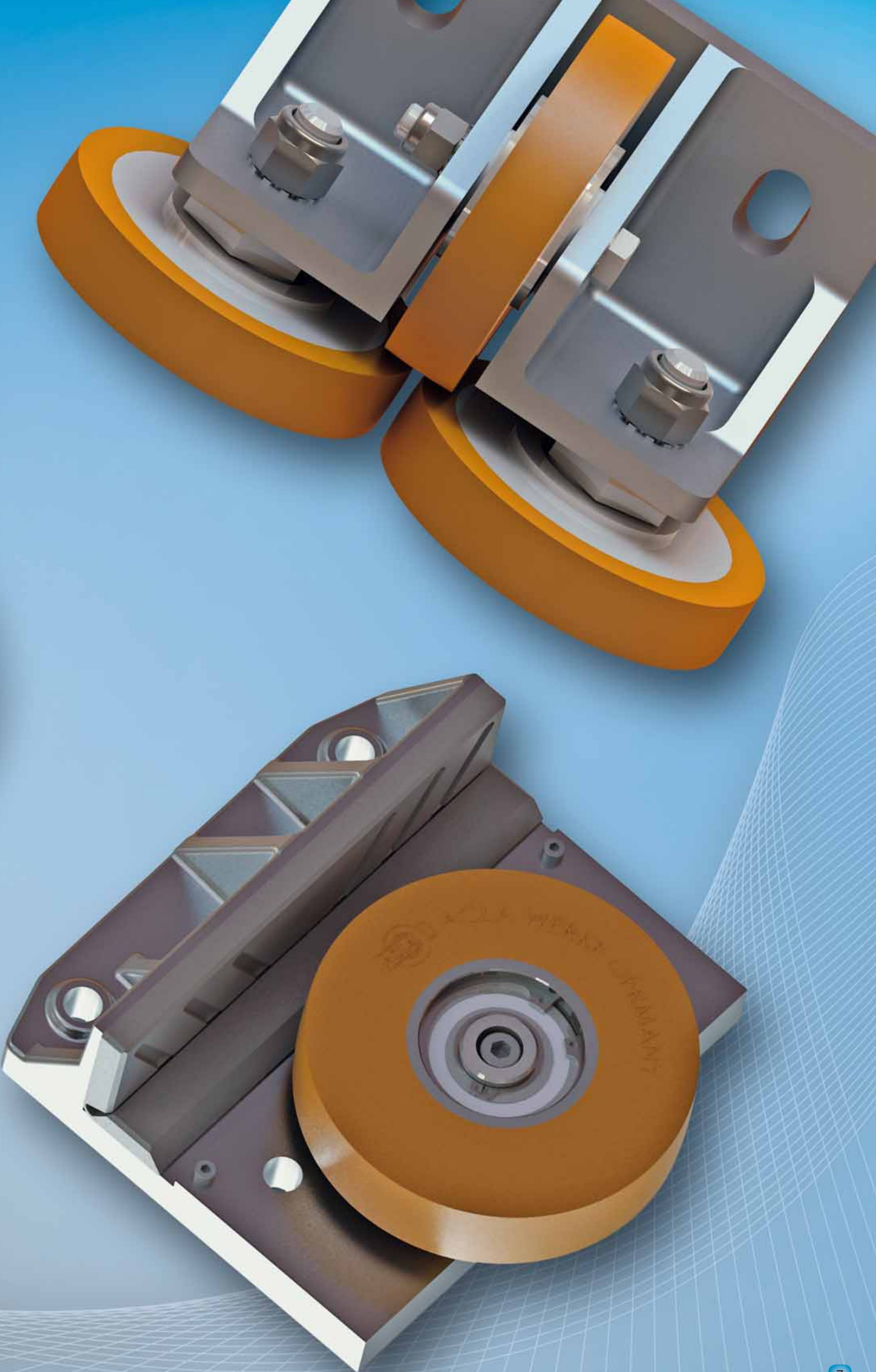

Roller Guide AR 3

ø 150 x 40 to ø 200 x 40

Also available as „special execution“ with particularly high-quality installation components.

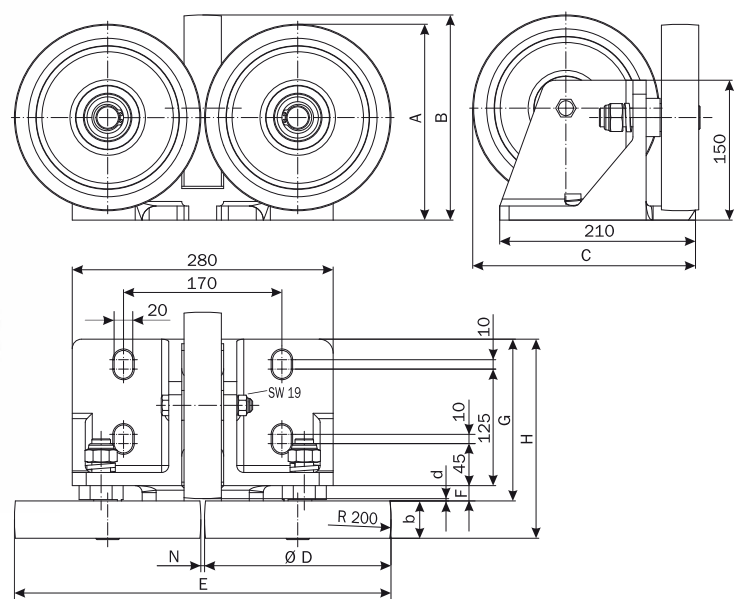

Design Details

- Infinitely adjustable to rail width from **4 to 36 mm** in no time. A gap between roller and rail of 0,1 to 0,5 mm has to be considered
- Excentrically adjustable king pins, SW 41
- The breaking limit of the base support is approx. 40 kN

art. no.	rollers ø D x b	complete weight ca. kg	no. of ball bearings	*max. load [N] per roller with v nominal [m/s]				mounting dimensions								
				0,63	1,0	2,5	4	A	B	C	d	E	N	F	G	H
142 836.04	150 x 40	12	2	5.460	5.140	3.990	2.900	max. 176	169	188	4,5	max. 330	6 - 34	17,5	172,5	212,5
142 380.04	180 x 35	13	2	5.150	4.990	4.310	3.000	max. 207	200	219	4,5	max. 396	9 - 36	18,5	175,5	210,5
142 389.04	200 x 40	16	2	6.300	6.090	5.250	3.700	max. 217	220	239	2,5	max. 432	4 - 32	16,5	173,5	213,5

*Information as to load: The load of the central roller decreases depending on the relation between rails and roller width.

Angled Roller Guide ARW 2

ø 80 x 20

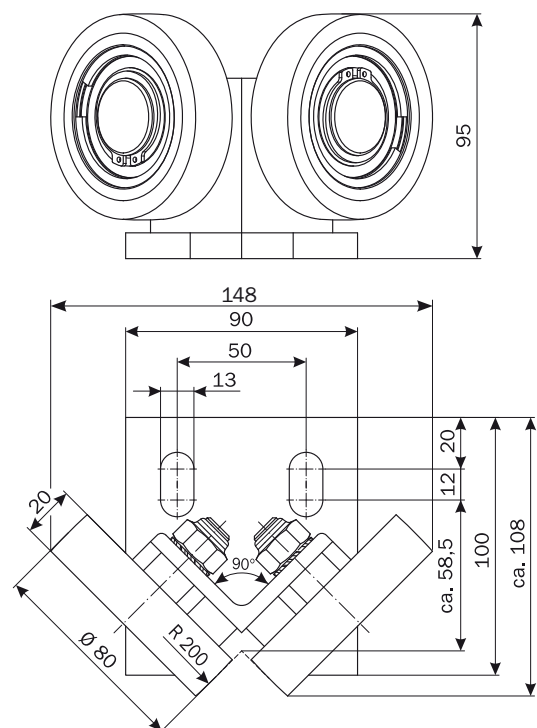
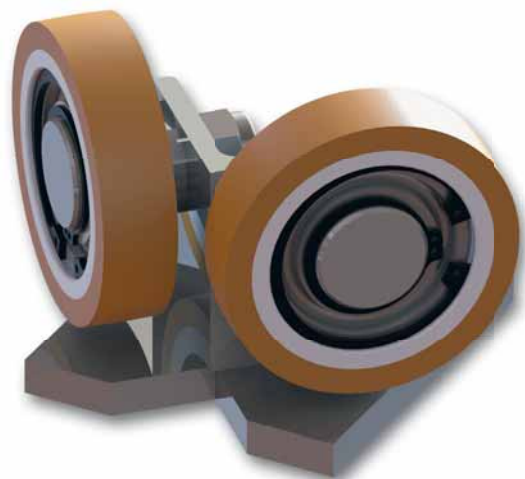

Design Details

- for angled rails and rondles

art. no.	rollers ø D x b	complete weight ca. kg	max. load [N] per roller with v nominal [m/s]		
			0,63	1,0	2,5
142 993.04	80 x 20	2,0	1.580	1.370	1.050

Mounting instruction: Between roller and rail a gap of 0,1 to 0,5 mm is to be considered at the oblong hole of the support base.

Spring loaded Roller Guide AR 1F

ø 100 x 25

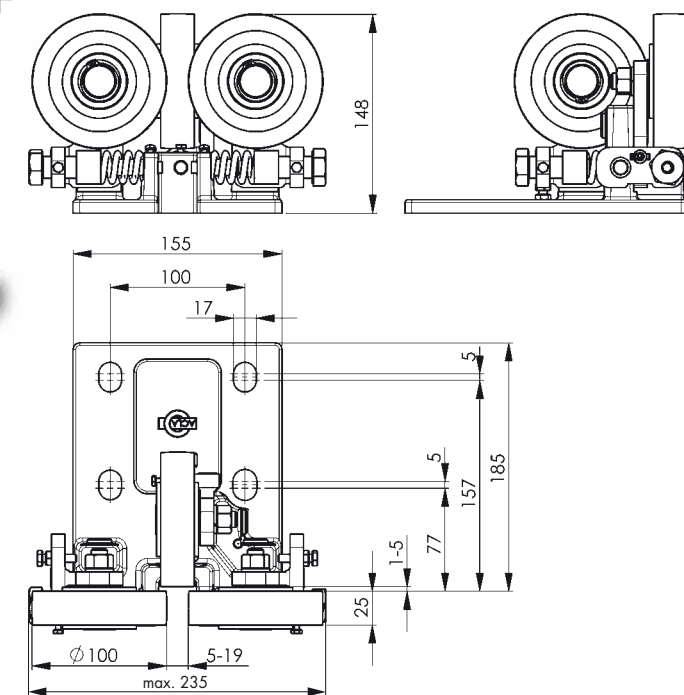
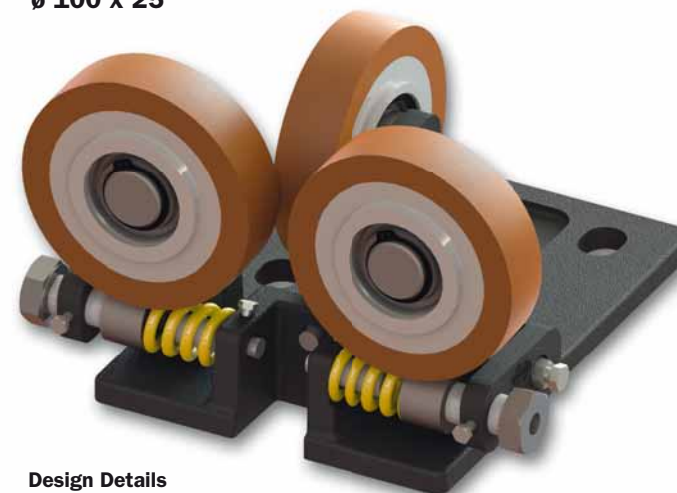

Design Details

- Infinitely adjustable to rail width from **5 to 19 mm** in no time
- Spring stroke and emergency stops are adjustable
- A wide range of springs is applicable (see table below)
- Due to the execution in steel cast the breaking load of the support is considerably higher than for the Aluminium die casts supports
- Each roller is equipped with two ball bearings

art. no.	rollers ø D x b	complete weight ca. kg	*max. load [N] per roller with v nominal [m/s]		
			0,63	1,0	2,5
pls. see table on the right	100 x 25	8,2	2.260	2.210	1.820

*Information as to load: The load of the central roller decreases depending on the relation between rails and roller width.

Spring configuration					
spring	SWB 25-30	SWH 25-30	SWM 25-30	SWL 25-31	SWF 25-32
hardness	extremely hard	hard	middle	soft	extremely soft
spring rate	400 N/mm	255 N/mm	128 N/mm	69 N/mm	33 N/mm
colour	brown	green	red	blue	yellow
art. no.	143 284	143 284.02	143 284.01	143 284.03	143 284.04

Spring loaded Roller Guide AR 3F

ø 148 x 20

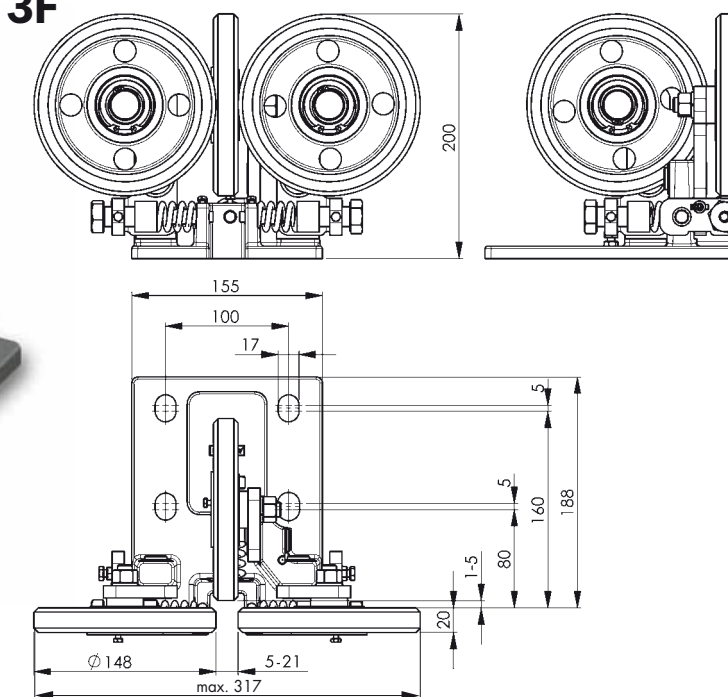

Design Details

- Infinitely adjustable to rail width from **5 to 21 mm** in no time
- Spring stroke and emergency stops are adjustable
- A wide range of springs is applicable (see table below)
- Due to the execution in steel cast the breaking load of the support is considerably higher than for the Aluminium die casts supports
- Each roller is equipped with two ball bearings

art. no.	rollers ø D x b	complete weight ca. kg	*max. load [N] per roller with v nominal [m/s]		
			0,63	1,0	2,5
pls. see table on the right	148 x 20	9,9	3.190	3.000	2.330

*Information as to load: The load of the central roller decreases depending on the relation between rails and roller width.

Spring configuration					
spring	SWB 25-30	SWH 25-30	SWM 25-30	SWL 25-31	SWF 25-32
hardness	extremely hard	hard	middle	soft	extremely soft
spring rate	400 N/mm	255 N/mm	128 N/mm	69 N/mm	33 N/mm
colour	brown	green	red	blue	yellow
art. no.	143 448	143 448.02	143 448.03	143 448.04	143 448.05

Focus on quality in ACLA production processes



Roller Sliding Guide HSM RG

with roller $\varnothing 80 \times 20$

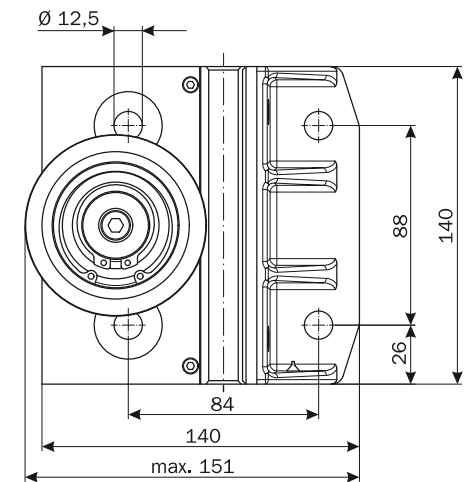
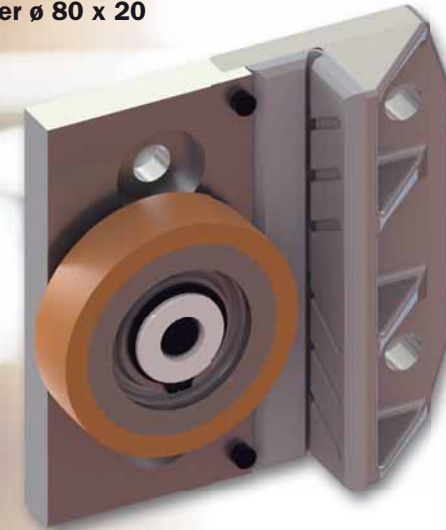

Design details

- Aluminium guide shoe with half a guide shoe insert of ACLASYN GR as sliding guide
- For rail widths from 5 to 16 mm

art. no.	rail width [mm]	rollers $\varnothing D \times b$	complete weight ca. kg	max. load [N] per roller with v nominal [m/s]		
				0,63	1,0	2,5
142 988.04	16	80 x 20	1,1	1.580	1.370	1.050
142 988.05	9	80 x 20	1,1	1.580	1.370	1.050
142 988.06	5	80 x 20	1,1	1.580	1.370	1.050

Mounting instruction: Between roller/sliding guide and rail a gap of 0,1 to 0,5 mm is to be considered.

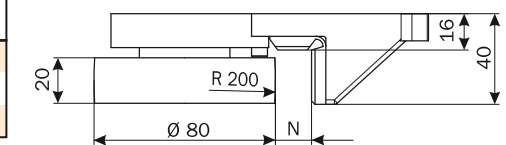

Roller Sliding Guide HSML RG

with roller $\varnothing 100 \times 30$ or $\varnothing 125 \times 30$

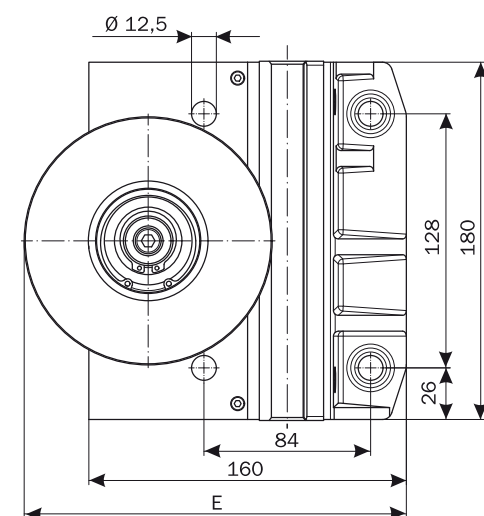

Design details

- Aluminium guide shoe with half a guide shoe insert of ACLASYN GR as sliding guide
- For rail widths from 5 to 19 mm

art. no.	rollers $\varnothing D \times b$	complete weight ca. kg	max. load [N] per roller with v nominal [m/s]			mounting dimensions E
			0,63	1,0	2,5	
142 987.04	100 x 30	2,1	2.730	2.520	2.100	max. 195
142 786.04	125 x 30	2,3	3.300	3.100	2.800	max. 182,5

Mounting instruction: Between roller/sliding guide and rail a gap of 0,1 to 0,5 mm is to be considered.

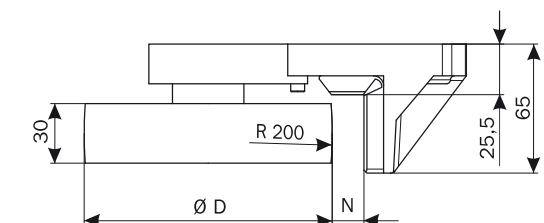

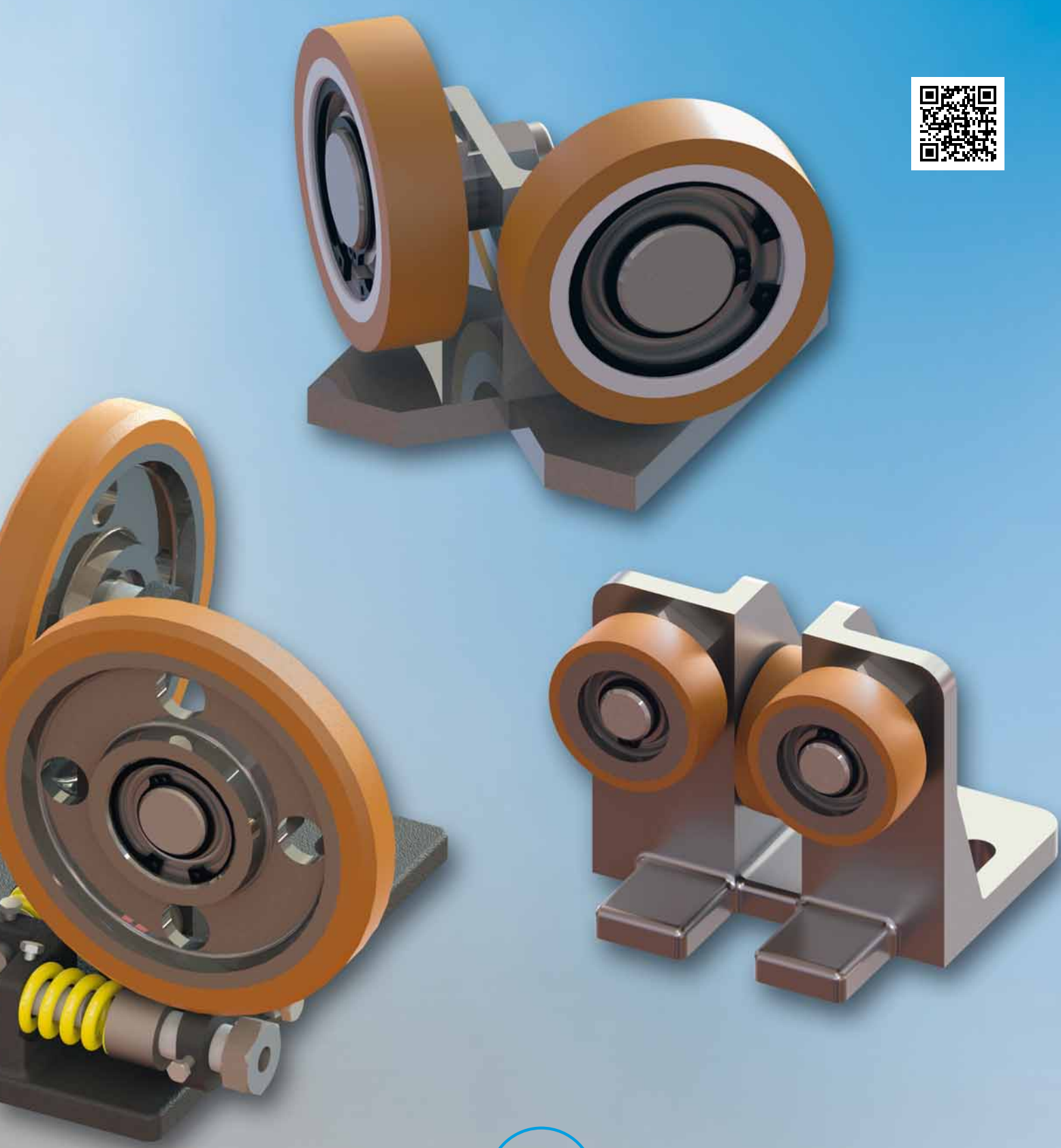

ACLA-WERKE GMBH

Frankfurter Str. 142-190 · 51065 Köln · Germany · Tel. +49 (0)221/69998-0 · Fax +49 (0)221/697121 · e-mail: info@acla-werke.de · www.acla-werke.de

ACLA USA, INC.

509 Thomson Park Drive · Cranberry TWP, PA 16006 · Tel. +1 724 / 7 76 00 99 · Fax +1 724 / 7 76 04 77 · e-mail: andym@aclausa.com

ACLA FRANCE POLYURETHANE S.A.R.L.

Z.A. de la Fontaine des Tournelles · F-77230 Saint-Mard · Tel. +33 (0)1 64 02 77 87 · Fax +33 (0)1 64 02 79 27 · e-mail: aclafrance@acla-werke.de; acla.france@wanadoo.fr

Dimensions in mm. We reserve the right to change sizes. Further dimensions and special types on request. Our verbal or written recommendations for any application as well as tests are carried out to the best of our knowledge. They are without engagement also as far as patent rights of third parties are concerned, and do not exempt you from checking the products supplied by us to their suitability for the intended procedure and purpose. Application, use and processing of the products are outside our control, and are exclusively the responsibility of the customer. Moreover our general sales conditions apply.

© ACLA-WERKE GMBH. Printed in Germany. All figures are protected in copyright matters. Each duplication requires the agreement of ACLA-WERKE GMBH, 51065 Cologne/Germany.