



Industrie Service

EC type-examination certificate

Certificate no.:	AGB 065/6
Notified body:	TÜV SÜD Industrie Service GmbH Zertifizierungsstelle für Aufzüge und Sicherheitsbauteile Westendstraße 199, 80686 München - Germany
Applicant/ Certificate holder:	P.F.B. s.r.l. Via Raimondo Dalla Costa, 690 41100 Modena - Italy
Date of submission:	2006-05-09
Manufacturer:	P.F.B. s.r.l. Via Raimondo Dalla Costa, 690 41100 Modena - Italy
Product, type:	Overspeed governor, type R6
Test Laboratory:	TÜV SÜD Industrie Service GmbH Prüfbereich Aufzüge und Sicherheitsbauteile Westendstrasse 199, 80686 München - Germany
Date and number of test report:	2006-05-19 065/6
EC-directive:	95 / 16 / EG
Statement:	The safety component conforms to the directives safety requirements for the respective scope of application stated on page 1 of the Annex to this EC type-examination certificate.
Certificate date:	2006-05-19

Zertifizierungsstelle für Aufzüge und Sicherheitsbauteile
EC identification number: 0036

D. Roas

Dieter Roas





Industrie Service

Annex of EC type-examination certificate no. AGB 065/6

1. Scope of application

1.1	Permissible tripping speed	0,44 – 2,40 m/s
1.2	Permissible rated speed	≤ 2,09 m/s
2.3	Driving rope	
1.3.1	Category	Round strand rope made of steel wire
1.3.2	Diameter	6 – 8 mm
1.4	Minimum tension force (force produced by the tensioning weight, acting on the axis of rope diverting pulley)	
1.4.1	Tension force determined in the test (new rope and groove)	222 N
2.3.A	Tension force determined by calculation (coefficient of friction $\mu = 0,09$)	706 N
1.5	Tensile force at minimum tension force	550 N

2. Remarks

- 2.1 The adjusted tripping speed, the safety switch and the weight of the operating lever must be sealed against unauthorised adjustment (safety switch and weight of the operating lever for example by colour sealing of the fastening bolts. Safety switch only if switching off is required prior to achieving the tripping speed)
- 2.2 The direction of rotation for retracting the safety gear is to be marked at the overspeed governor.
- 2.3 Design with and without preliminary switch off intended.
- 2.4 Remote tripping device permissible
- 2.5 Remote resetting device of the safety switch permissible
- 2.6 In order to provide identification and information about the basic design and its functioning and to show the environmental conditions and connection requirements pertaining to the tested and approved type, and to differentiate it from others, drawing No. 96/5001 index number 1 dated November 2001 is to be enclosed with EC type-examination certificate and the annex thereto.
- 2.7 The EC type - examination certificate may only used in connection with the pertinent annex.

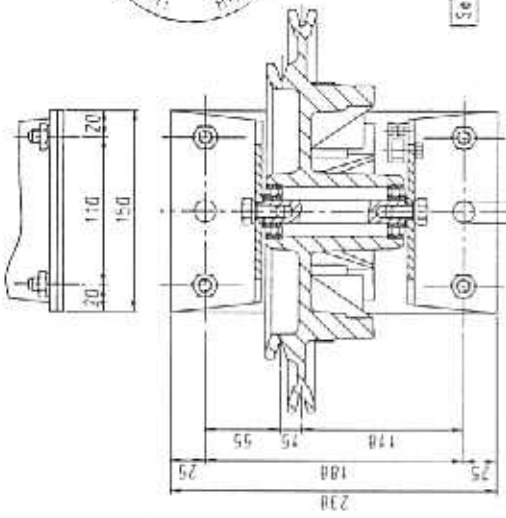

10. DEC. 2001
VERSIONE STANDARD
STANDARD VERSION
(R. 6/DX - R. 6/SX)

GEPROUFT -
 TÜV SÜDTIROL
 Aufwachen, Aufpassen, Achtung, Achtung, Achtung
 Wachen, Achtung, Achtung, Achtung, Achtung
 Achtung, Achtung, Achtung, Achtung, Achtung

Set A-A

N°2 FORI Ø15

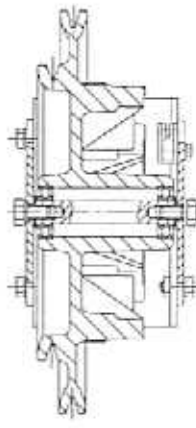

VERSIONE 'R' INGOMBRO RIDOTTO
VERSION 'R' WITH SMALL BASE
(R. 6/RDX - R. 6/R SX)



Set A-A

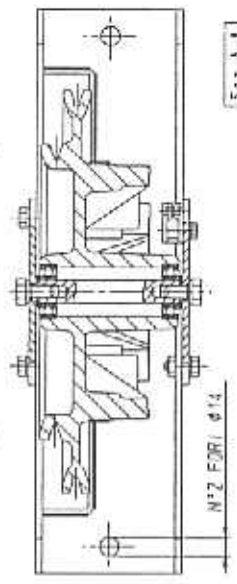
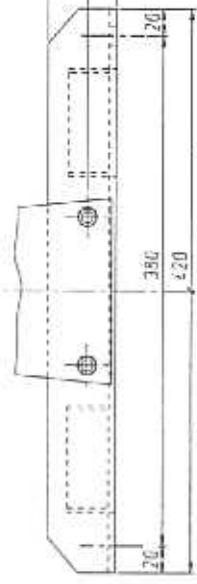

VERSIONE 'SP'
CON BASAMENTO SALVAFUNE
VERSION 'SP' WITH BASE
PROTECTION OF ROPE
(R. 6/SPDX - R. 6/SPSX)

Set A-A

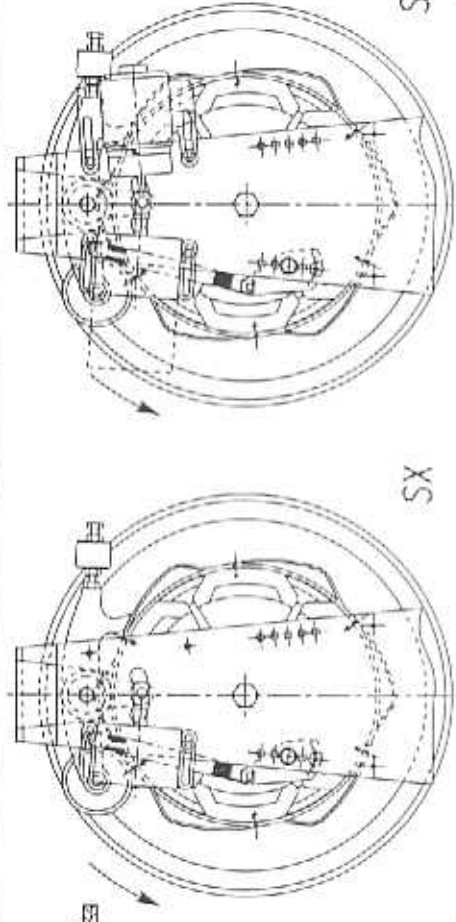
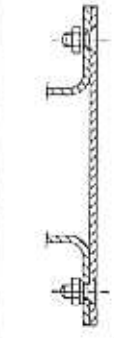

SX

SX

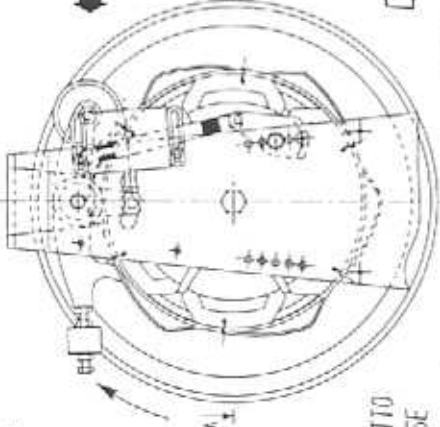

DX

DX

DIVERSE VERSIONI
DIFFERENT VERSIONS

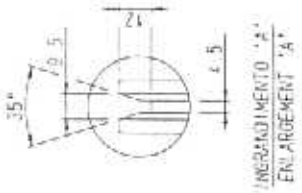

INGRANDIMENTO 'A'
 ENLARGEMENT 'A'

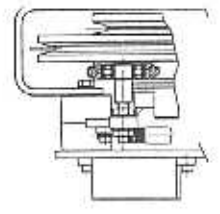

VISTA DA 'B'

CONTATTO AUTOMATICO
 AUTOMATIC RESET SWITCH
 COMANDO PIANO A DISTANZA
 REMOTE RESET SWITCH

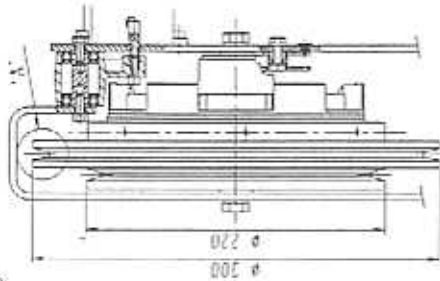

MODIFICHE - MODIFIKATIONEN

NR.	DATA	DESCRIZIONE
NO.	DATA	BESCHREIBUNG
1	11/01	MODIFICATO SALTARELLO E AGGIUNTA VERSIONE CON COMANDO A DISTANZA

Smussi non quotati	45°	scale	1/4	q. ca'	LAVOR. GEN.	NOTE
Raggi non quotati					MATERIALE	
TOLL. QUOTE LIBERE					DENOMINAZIONE	
S.L.					COMPLESSIVO	
RUGG.					GRUPPO LIMITATORE DI VELOCITA' R. 6	
TOLL.					MACCHINA	
▽	± 0.2				DIST. N°	
▽▽	± 0.15				COMP.L. N°	
▽▽▽	± 0.1				DIST. N°	
▽▽▽▽	± 0.05				DIST. N°	
▽▽▽▽▽	± 0.02				DIST. N°	
▽▽▽▽▽▽	± 0.01				DIST. N°	
▽▽▽▽▽▽▽	± 0.005				DIST. N°	
▽▽▽▽▽▽▽▽	± 0.002				DIST. N°	
▽▽▽▽▽▽▽▽▽	± 0.001				DIST. N°	
QUALITA'					MATERIALE	
STATO N° - MOD.					MATERIALE	
DIMEN.					MATERIALE	
PESO Kg.					MATERIALE	
T.T.					MATERIALE	
DIS.					MATERIALE	
VER.					MATERIALE	
DATA					MATERIALE	
10/9					MATERIALE	
COMP.L. N°					MATERIALE	
DIST. N°					MATERIALE	
96/6001					MATERIALE	

