

SCELTA DEL TENDITORE A MOLLA R4M / R4MS
CHOICE OF SPRING TENSIONER R4M / R4MS

PARAMETRI DI SCELTA	CHOICE PARAMETERS	TIPO TYPE R4M	TIPO TYPE R4MS
PULEGGIA Ø 120	PULLEY Ø 120	●	●
PULEGGIA Ø 150	PULLEY Ø 150	●	●
PULEGGIA Ø 180	PULLEY Ø 180	●	●
PULEGGIA Ø 200	PULLEY Ø 200	●	●
PULEGGIA Ø 250	PULLEY Ø 250	—	—
PULEGGIA Ø 300	PULLEY Ø 300	—	—
PULEGGIA Ø 315	PULLEY Ø 315	—	—
FUNE DA 6 A 6,5 mm.	ROPE FROM 6 TO 6,5 mm.	●	●
FUNE DA 6 A 8 mm.	ROPE FROM 6 TO 8 mm.	—	—
FUNE DA 8 A 10 mm.	ROPE FROM 8 TO 10 mm.	—	—
VEL.INTERVENTO MAX 2,00 m/s.	MAX. TRIPPING SPEED 2,00 m/s.	●	●
FISSAGGIO ALLA GUIDA.	GUIDE RAIL FIXING	●	●
FISSAGGIO A PAVIMENTO	FLOOR FIXING	●	—
FISSAGGIO ALLA GUIDA E A PAVIMENTO	GUIDE RAIL AND FLOOR FIXING	●	—
CARTER DI PROTEZIONE	PROTECTION	●	●
ANTISCARRUCOLAMENTO	ROPE SAFETY GUARD	●	●

● = DISPONIBILE / AVAILABLE / — = NON DISPONIBILE / NOT AVAILABLE



COMPONENTI MECCANICI
PER ASCENSORI
MECHANICAL LIFT
COMPONENTS

TENDITORE A MOLLA R4M

SPRING TENSIONER R4M

T242

CON PULEGGE Øp 120/150/180/200
WITH PULLEY Øp 120/150/180/200

PULEGGIA IN ALTO
PULLEY AT THE TOP

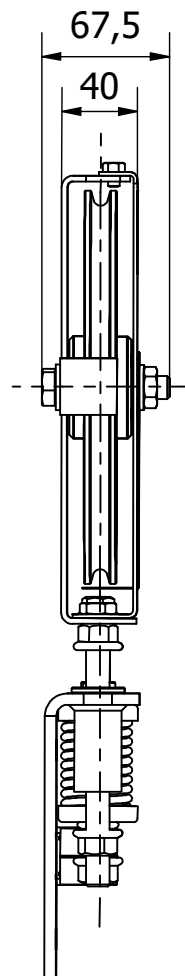
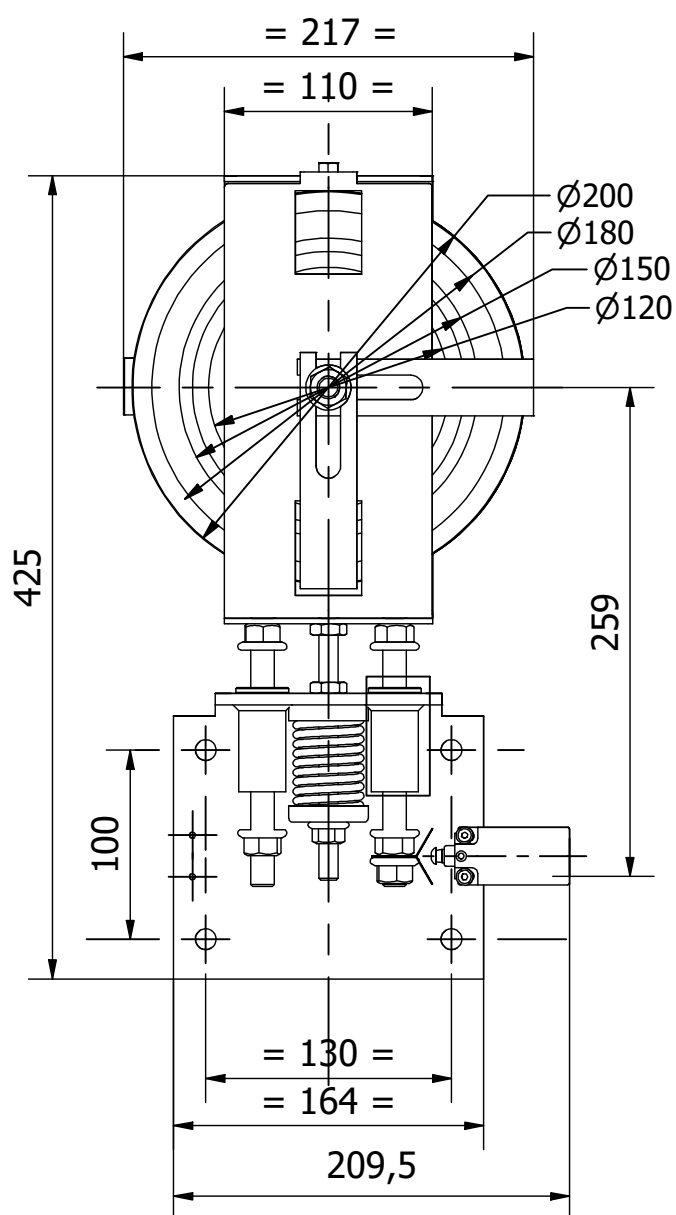

MICRO A SINISTRA
SWITCH ON THE LEFT

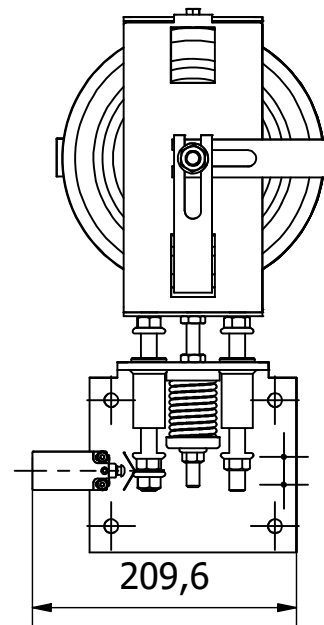

TIPO TENDITORE
SPRING TENSIONER TYPE

TIPO LIMITATORE DI VELOCITA'
OVERSPEED GOVERNORS TYPE

R4M

LK120

LX150

LX180

LX200

R5-R5R-R5S
LK200 INTERVENTO DISCESA
DOWN TRIPPING DIRECTION

R4M PER FISSAGGIO A PAVIMENTO
R4M FOR FLOOR FIXING

15 N° 2
ASOLE/SLOTS

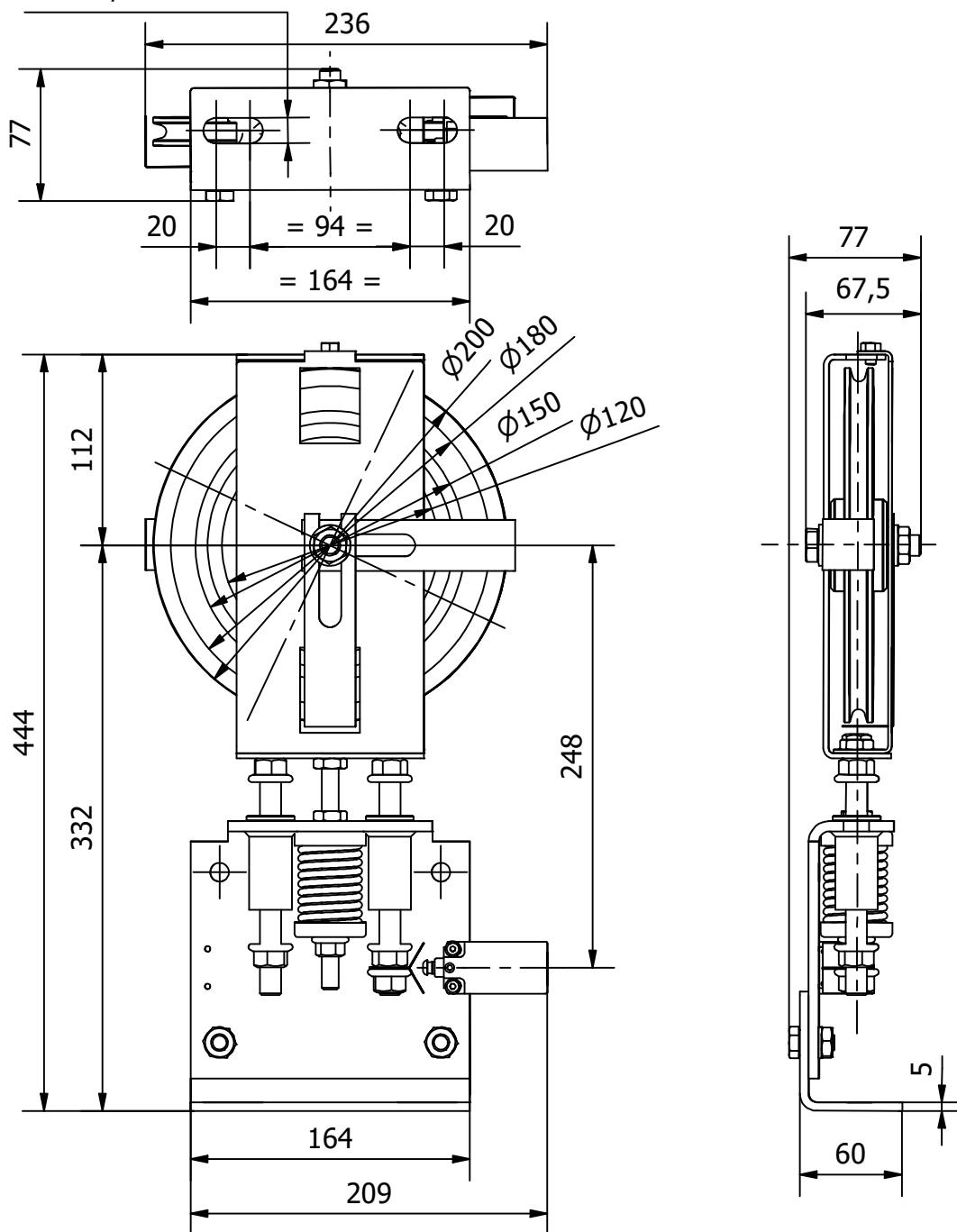

TENDITORE A MOLLA R4M / SPRING TENSIONER R4M	
TIPO / TYPE	CODICE / CODE
R4M Ø 120	8024213000M
R4M Ø 150	8024215000M
R4M Ø 180	8024218000M
R4M Ø 200	8024220000M

PIASTRA TENDITORE A MOLLA R4M PER FISSAGGIO A PAVIMENTO
PLATE SPRING TENSIONER R4M FOR FLOOR FIXING

PIASTRA FISSAGGIO
FIXING PLATE

CODICE
CODE

8015000100

R4M PER FISSAGGIO ALLA GUIDA
R4M FOR GUIDE RAIL FIXING

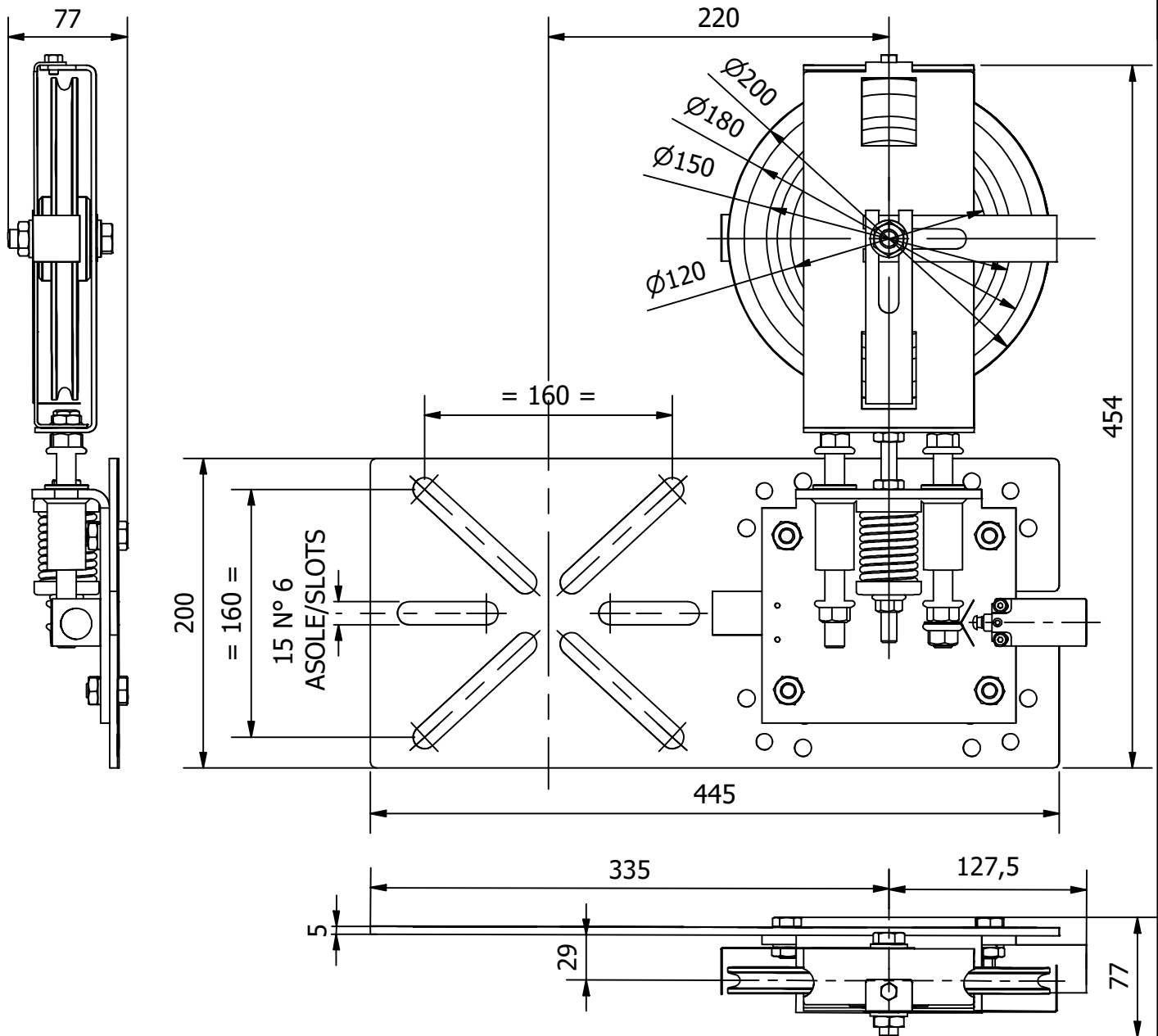

TENDITORE A MOLLA R4M / SPRING TENSIONER R4M	
TIPO / TYPE	CODICE / CODE
R4M Ø 120	8024213000M
R4M Ø 150	8024215000M
R4M Ø 180	8024218000M
R4M Ø 200	8024220000M

PIASTRA TENDITORE A MOLLA R4M PER FISSAGGIO ALLA GUIDA
PLATE SPRING TENSIONER R4M FOR GUIDE RAIL FIXING

PIASTRA FISSAGGIO
FIXING PLATE

CODICE
CODE

8015000090



COMPONENTI MECCANICI
PER ASCENSORI
MECHANICAL LIFT
COMPONENTS

TENDITORE A MOLLA R4MS
SPRING TENSIONER R4MS

T242

CON PULEGGE Øp 120/150/180/200
WITH PULLEY Øp 120/150/180/200

PULEGGIA IN BASSO
PULLEY AT THE BOTTOM

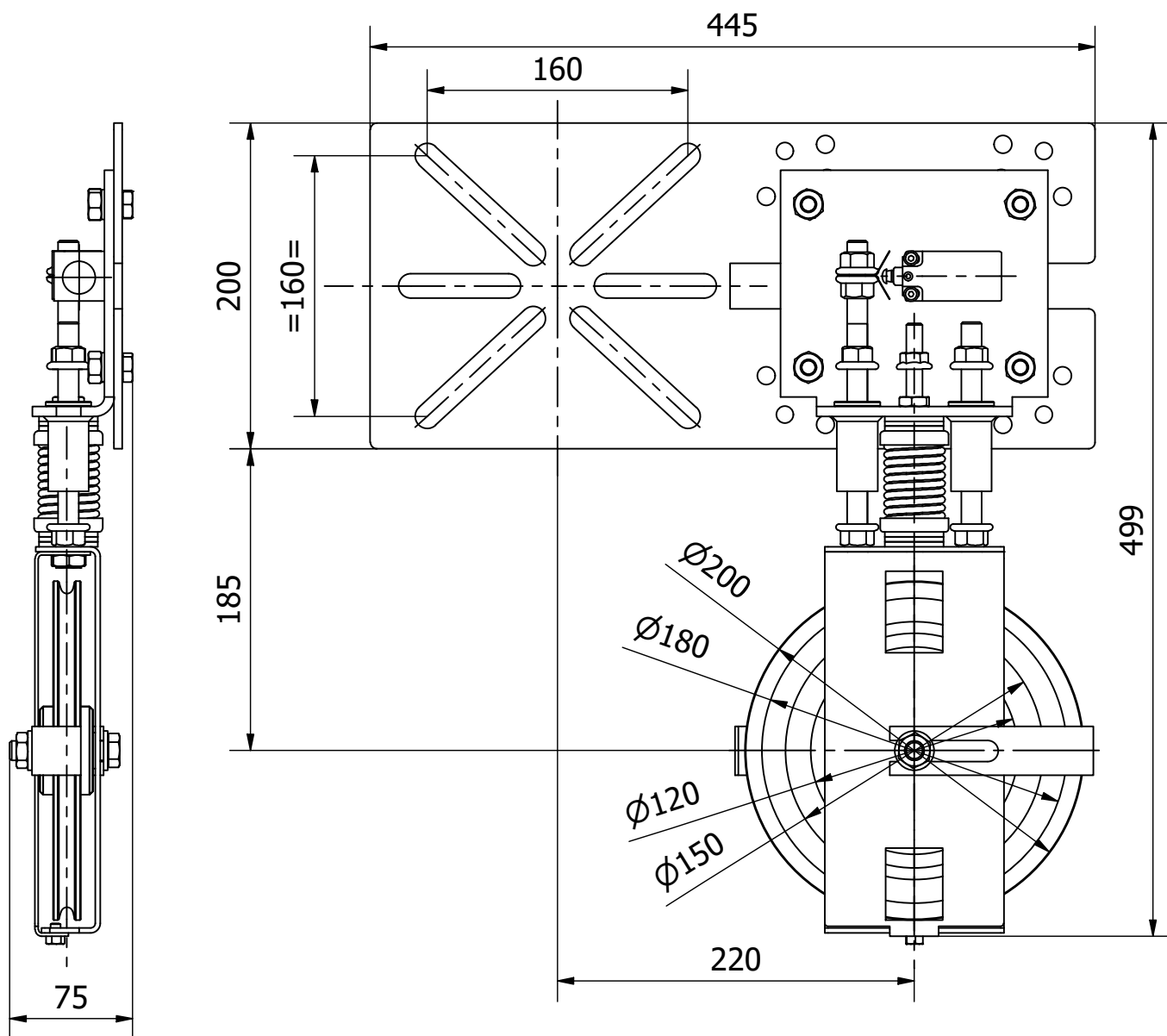

TIPO TENDITORE SPRING TENSIONER TYPE	TIPO LIMITATORE DI VELOCITA' OVERSPEED GOVERNORS TYPE
R4MS	LK120
	LX150
	LX180
	LX200
	R5-R5R-R5S LK200 INTERVENTO DISCESA DOWN TRIPPING DIRECTION

TENDITORE A MOLLA R4MS SPRING TENSIONER R4MS	
TIPO / TYPE	CODICE / CODE
R4MS Ø 120	8024213000MS
R4MS Ø 150	8024215000MS
R4MS Ø 180	8024218000MS
R4MS Ø 200	8024220000MS

CODICI TIPI TYPE CODE
--

TENDITORE A MOLLA R4MS / SPRING TENSIONER R4MS	
TIPO / TYPE	CODICE / CODE
R4MS Ø 120	8024213000MS
R4MS Ø 150	8024215000MS
R4MS Ø 180	8024218000MS
R4MS Ø 200	8024220000MS

TIPO TENDITORE SPRING TENSIONER TYPE	TIPO LIMITATORE DI VELOCITA' OVERSPEED GOVERNORS TYPE
R4MS	LK120
	LX150
	LX180
	LX200
	R5-R5R-R5S LK200 INTERVENTO DISCESA DOWN TRIPPING DIRECTION



TIPO "A"
TYPE "A"

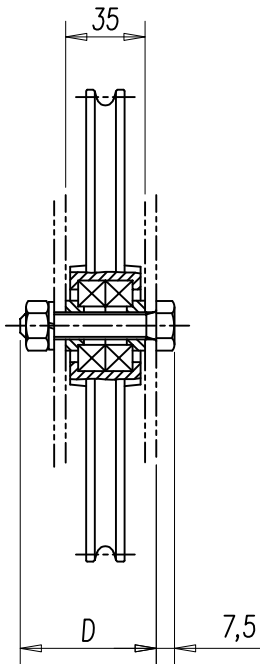

TIPO "B"
TYPE "B"

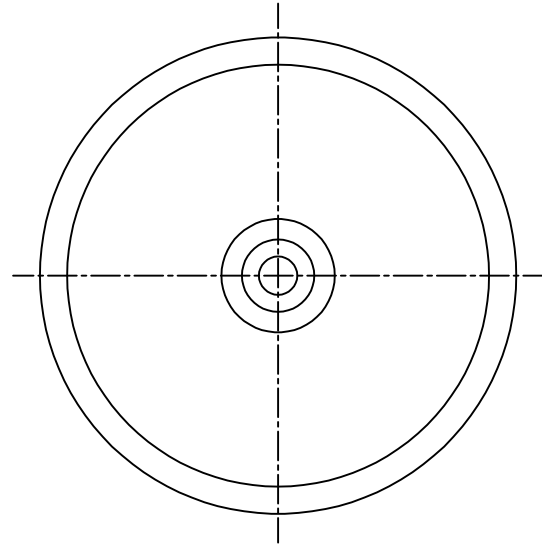
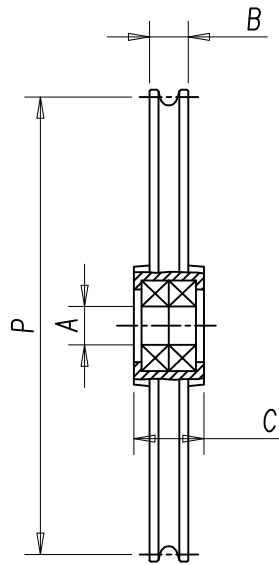

P	TIPO TYPE	Ø FUNE ROPE Ø	A	B	C	CUSCINETTO BALL BEARINGS	TIPO/TYPE R4M/R4MS		
							D	PUL.STANDARD IN POLIAMMIDE	PULEGGE IN GHISA CAST IRON PULLEYS
120	A	6-6,5	17	17	29	6203-ZZ	60	8025012000	-
	B						-	8025012010	-
150	A	6-6,5	17	17	32,5	6203-2RS	60	-	8025015100
	B						-	-	8025015110
180	A	6/6,5	17	17	32,5	6203-2RS	60	-	8025018100
	B						-	-	8025018110
200	A	6-6,5	17	17	32,5	6203-2RS	60	8025020000	8025020100
	B						-	8025020010	8025020110