

MAIN DIFFERENCES BETWEEN THE D-BOX AND THE SD-BOX

1.- GENERAL

The same casing with the same measurements has been kept, and only the design of the upper sticker has been updated, changing the position and function of certain LEDs, as can be seen in Figures 1 and 2.

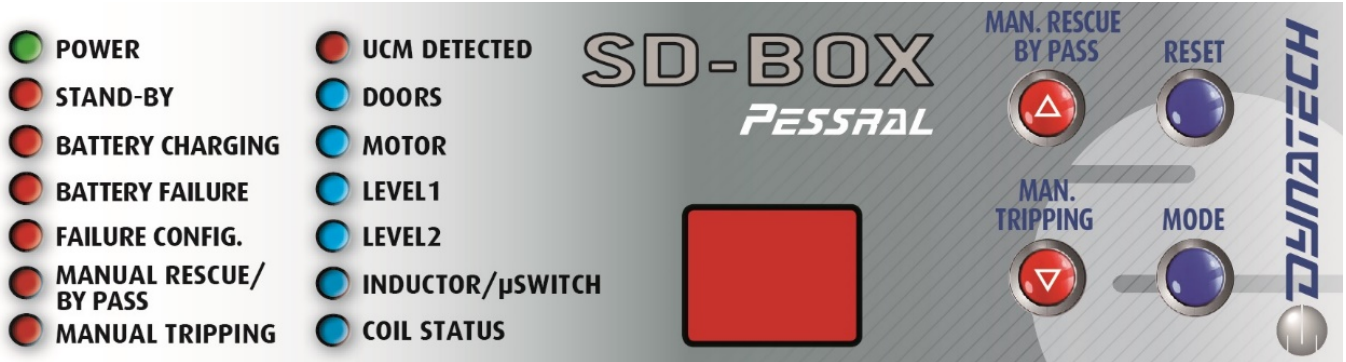

Figure 1 Upper sticker on SD-BOX

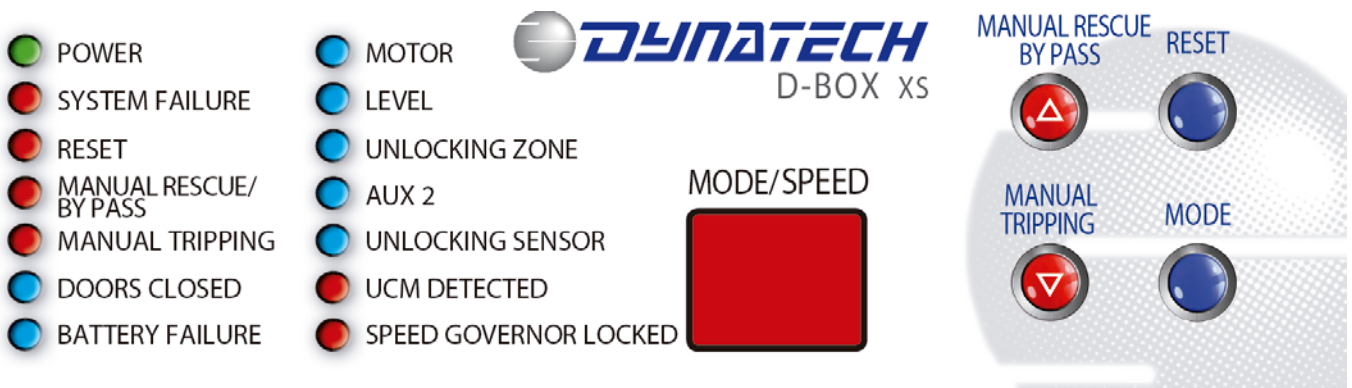

Figure 2 Upper sticker on D-BOX

2.- FUNCTIONS

The SD-BOX is certified as a SIL2 programmable electronic safety device (PESSRAL) according to Standards 81-20/50 to which new functions have been added in relation to the previous D-BOX.

The SD-BOX has its own certificate and, therefore, apart from maintaining the current assembly certificates (ASG with STAR/VEGA/QUASAR), it can be used with any other safety gear and/or speed governor.

A "STAND-BY" energy-saving mode has been implemented that switches off the display completely (except the STAND-BY LED, which indicates it is in saving mode) if no button is pressed for over 1 hour.

Furthermore, detection of the errors shown by the DISPLAY has been improved to differentiate and detect the problem more easily, with 23 different errors now defined in the new SD-BOX instead of the previous 6 errors, yet maintaining the same classification, such as the UCM detection "F2".

To perform a rescue or bypass, the MAN.RESCUE/BYPASS button must be kept pressed down on the new SD-BOX (or the EXT.MANUAL RESCUE input powered externally at 24V) for more than 3 seconds, unlike the previous D-BOX that did so instantly after pressing the button briefly. This avoids problems due to accidental button pushes, thus increasing system safety.

The type of output to be obtained with the FAILURE relay can also be programmed on the SD-BOX. Depending on the programme you select, the output relay can be enabled according to the status of the coil (on or off) or the relay can be enabled according to whether or not an error has been detected.

Unlike the D-BOX, the SD-BOX does not offer the possibility of changing the level signal logic according to its voltage. For the SD-BOX, the "level" will be detected by the LEVEL1 and LEVEL2 input when 24V is detected and "no level" will be detected at 0V.

3.- CONNECTIONS

The main power supply to the SD-BOX must be connected by using a 24V SELV/PELV source, and an auxiliary 12V battery can also be connected as back-up.

For read redundancy on the safety signals, 2 independent bypass level/zone sensors must be connected on the SD-BOX. 2 individual sensors or a double sensor can be installed, provided that the readings are independent and synchronised. Both 0-24V signals (0V off level and 24V on level) will be connected at the terminals marked LEVEL1 and LEVEL2.

The position of some of the inlets/outlets has been changed and the encoder input signal has been removed, as can be seen in the following figures:

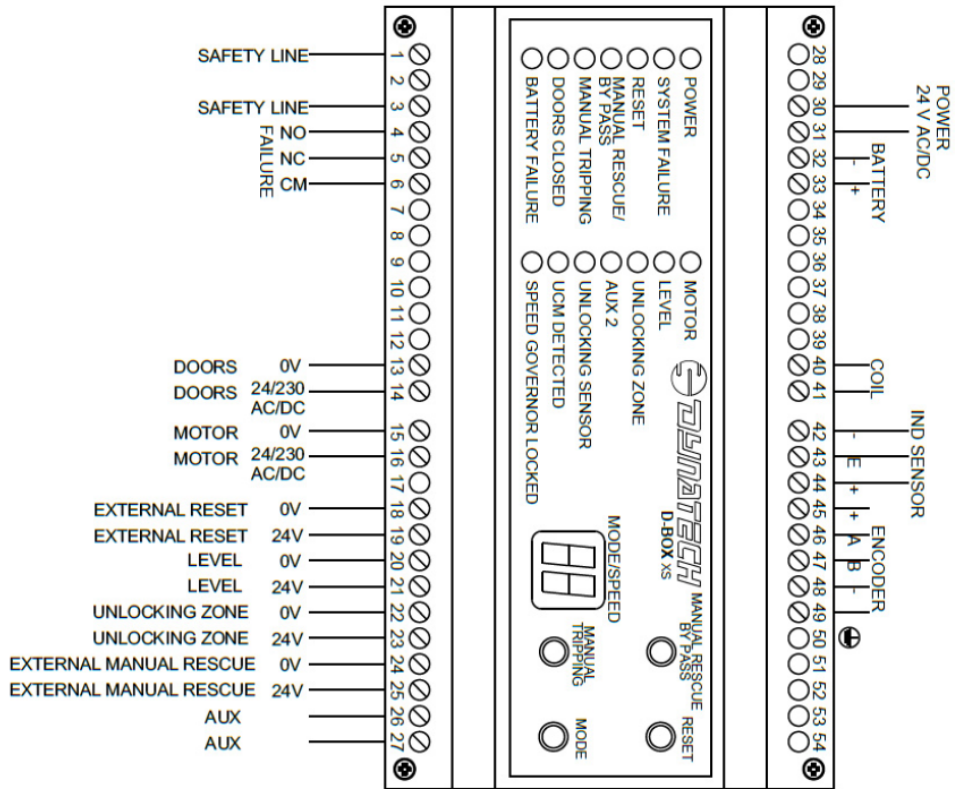

Figure 3 D-BOX connections

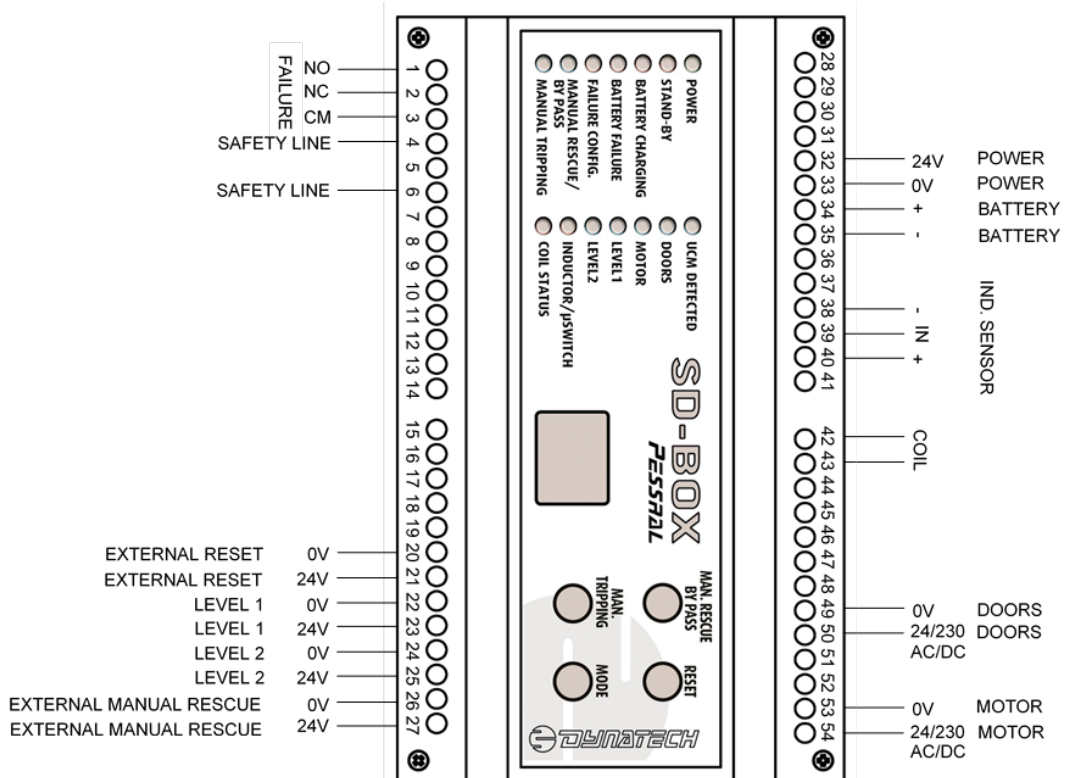

Figure 4 SD-BOX connections