

BOX M

INTERCOM FOR ELEVATOR MACHINE ROOM

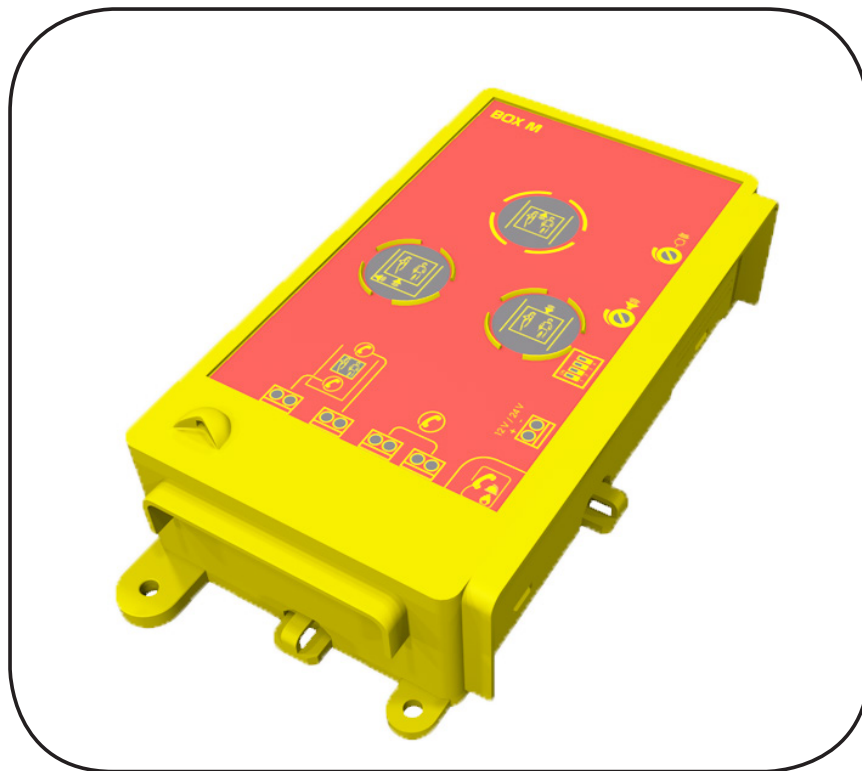

www.anepanywhere.com

TABLE OF CONTENTS

1 - GENERAL POINTS

Page 3

1 - BOX M Module Principle

2 - CONNECTIONS

Page 6

2.1 - BOX M Module power supply

2.2 - BOX M several connections

3 - INTERCOM FUNCTIONS

Page 7

3.1 - BOX M volume adjustment

3.2 - Machine room/car intercom

3.3 - Machine room/top of car intercom

3.4 - Under car/pit intercom

3.5 - Forced alarm

4 - FIREMAN INTERCOM

Page 9

4.1 - Fireman square

1 - GENERAL POINTS

BOX M module is an intercom system enables communication between :

- Machine room and top of car,
- Machine room and inside the car,
- Machine room and pit,
- « Fireman Square » module at main floor landing and inside car

BOX M complies with codes* regarding :

- Fireman square
- Lifts with travel higher than 30 meters
- Lift with remote machine room (i.e. : Hydraulic lifts).

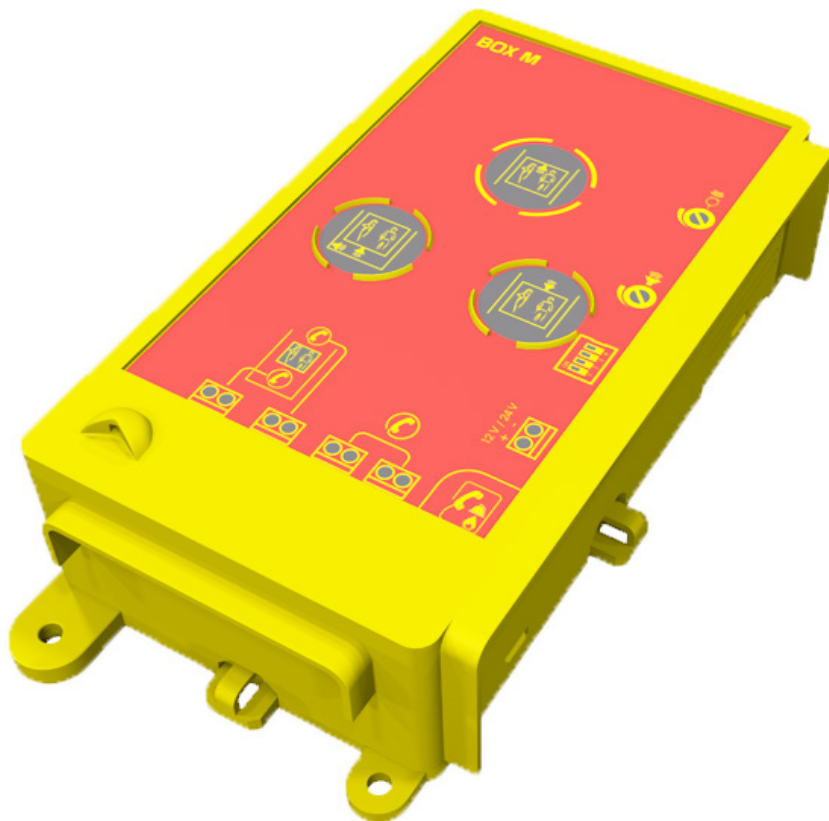

* Codes : EN 81 - 1 / EN 81 - 2 / EN 81 - 72

1 - BOX M Module principle

BOX M module is installed inside machine room or inside landing panel, depending upon lift's configuration.

Connections between devices are carried out by 2 electric wires, preferably shielded to avoid any external interference.

BOX M module works with other ANEP box range of products.

ANEP BOX - C, ANEP BOX - TA, ANEP BOX - TX, ANEP BOX - TX+

or with a simple analog telephone.

It allows the coupling of a 3 emergency voice point with a firefighter intercom, on a single telephone line.

The activation of the firefighter intercom (Square) has priority over all phases of intercom and communication.

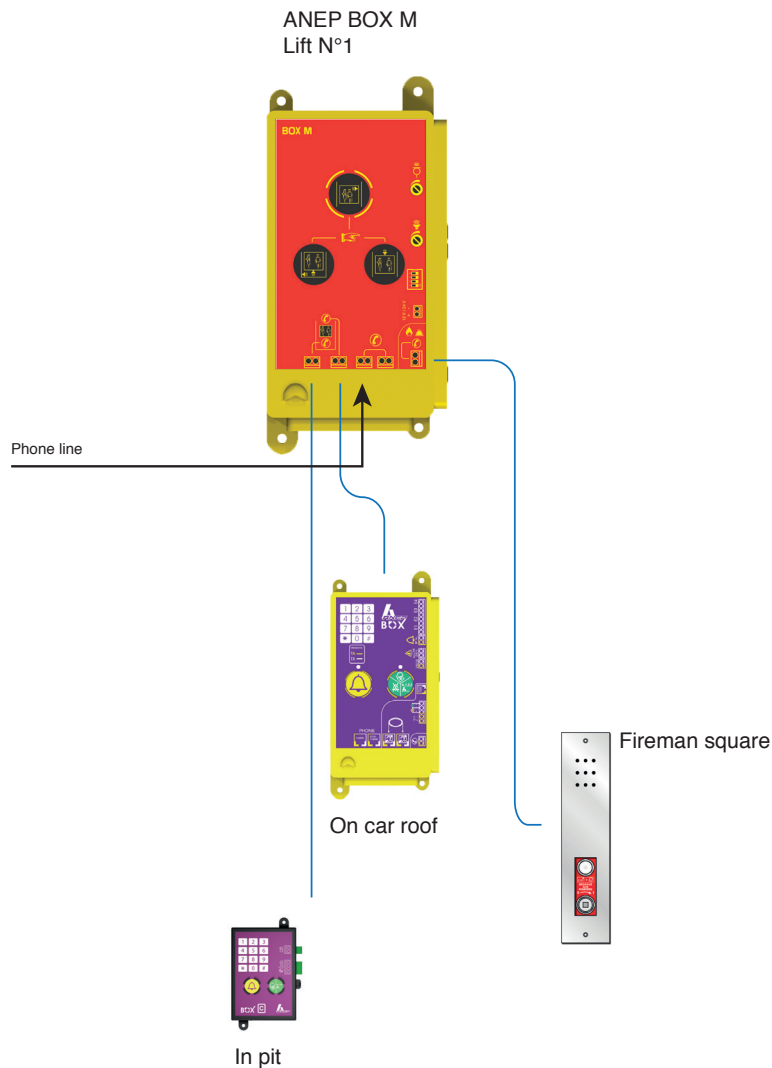

Example of configuration for 1 phone line and for one lift.

2 - CONNECTIONS

Module installed in machine room (1 per lift) for intercom functionalities :

- Mechanics machine room / shaft
(communication with top of car, inside car and under car or pit)
- Firemen / lift car
(communication between the fireman square and people inside the car)

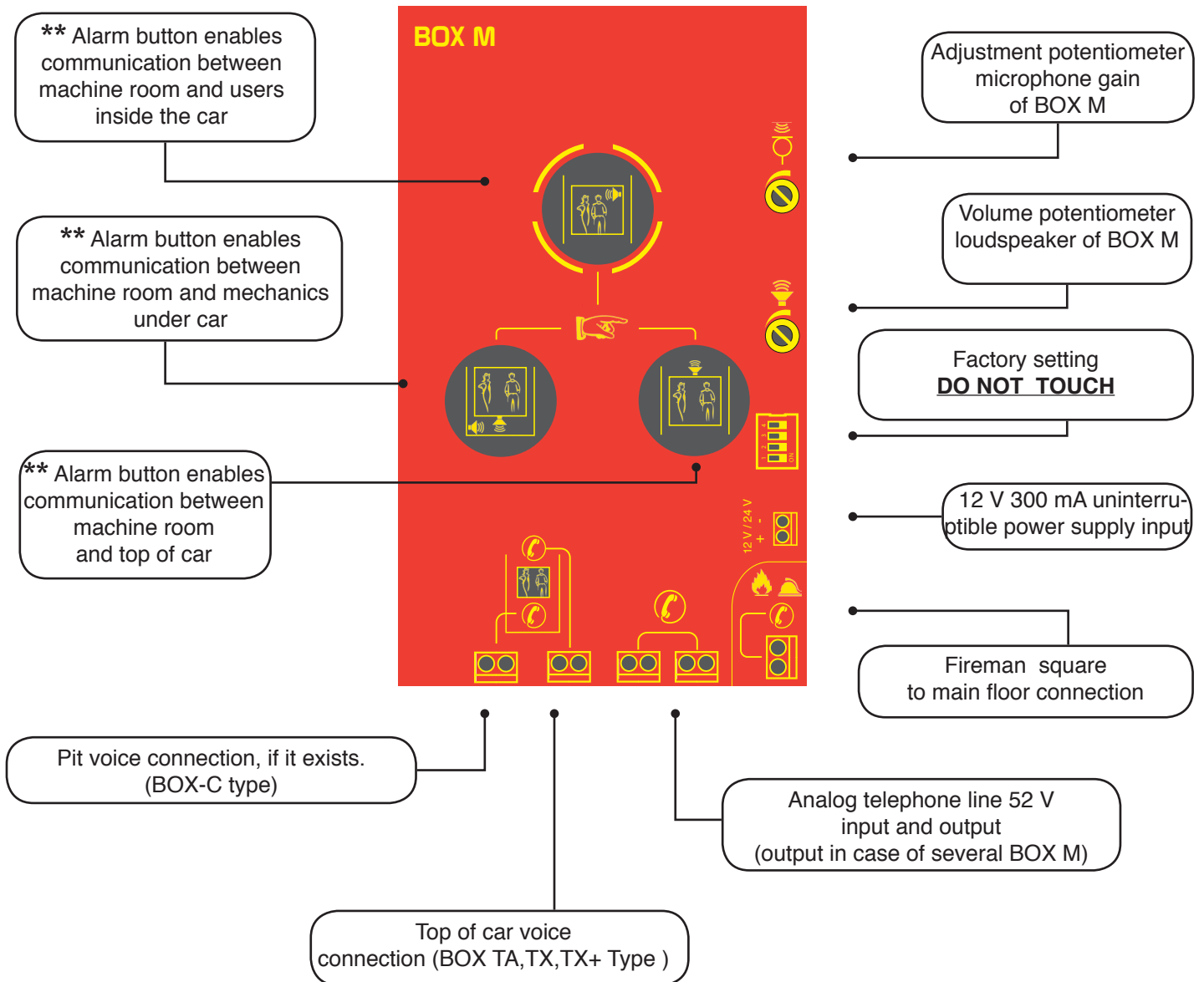

* 12 v 300 mA fireman less / 12 v 500 mA with fireman

**** NOTA : To talk from machine room press the dedicated button, once the button is released, listen to your correspondent for 30 sec, then BOX - M return to standby mode, to continue the conversation re-press the corresponding button.**

2.1 - BOX M Module power supply

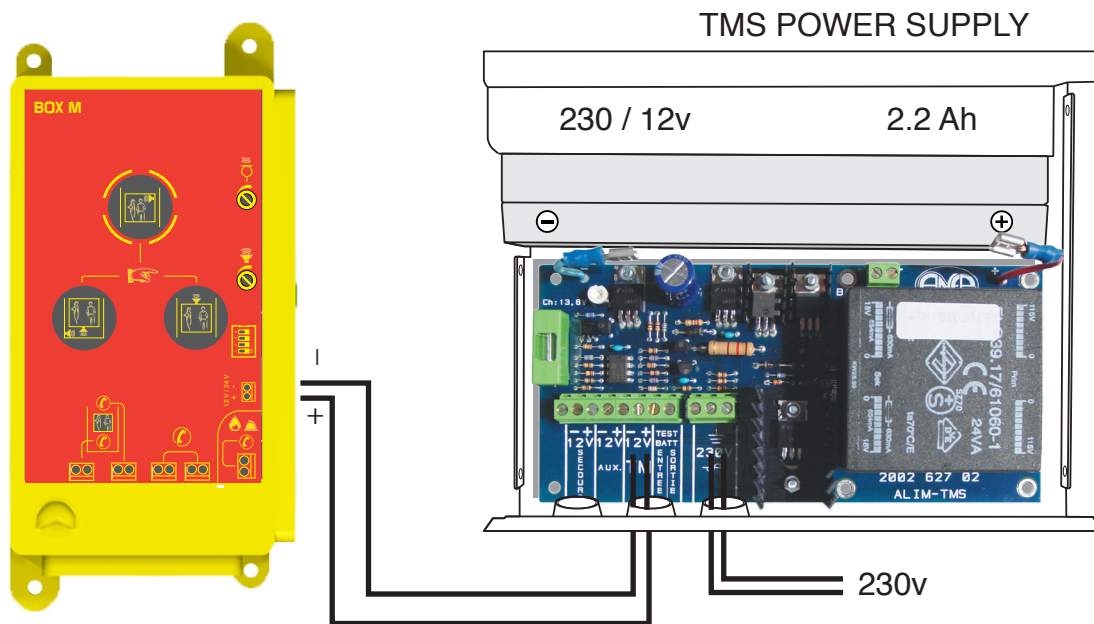

2.2 - Several BOX M connections



Factory setting, let dipswitch on « OFF » position.
(Future using)

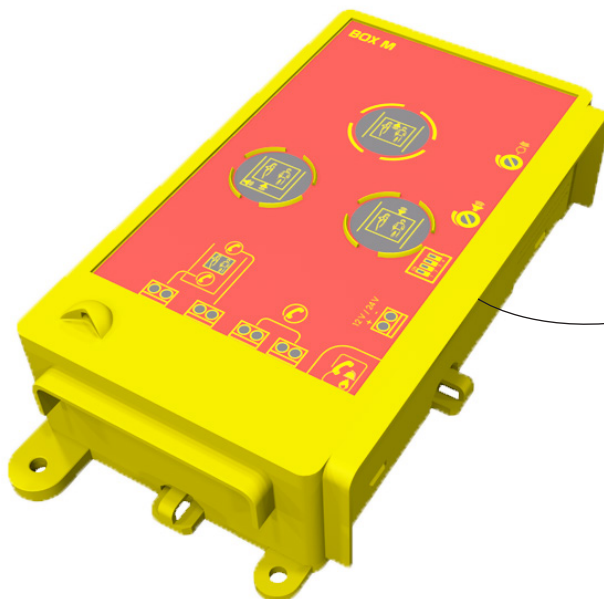
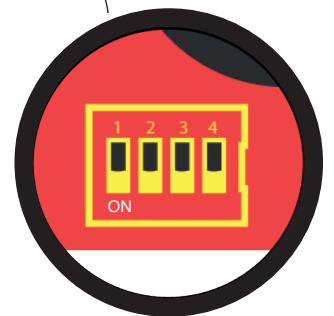

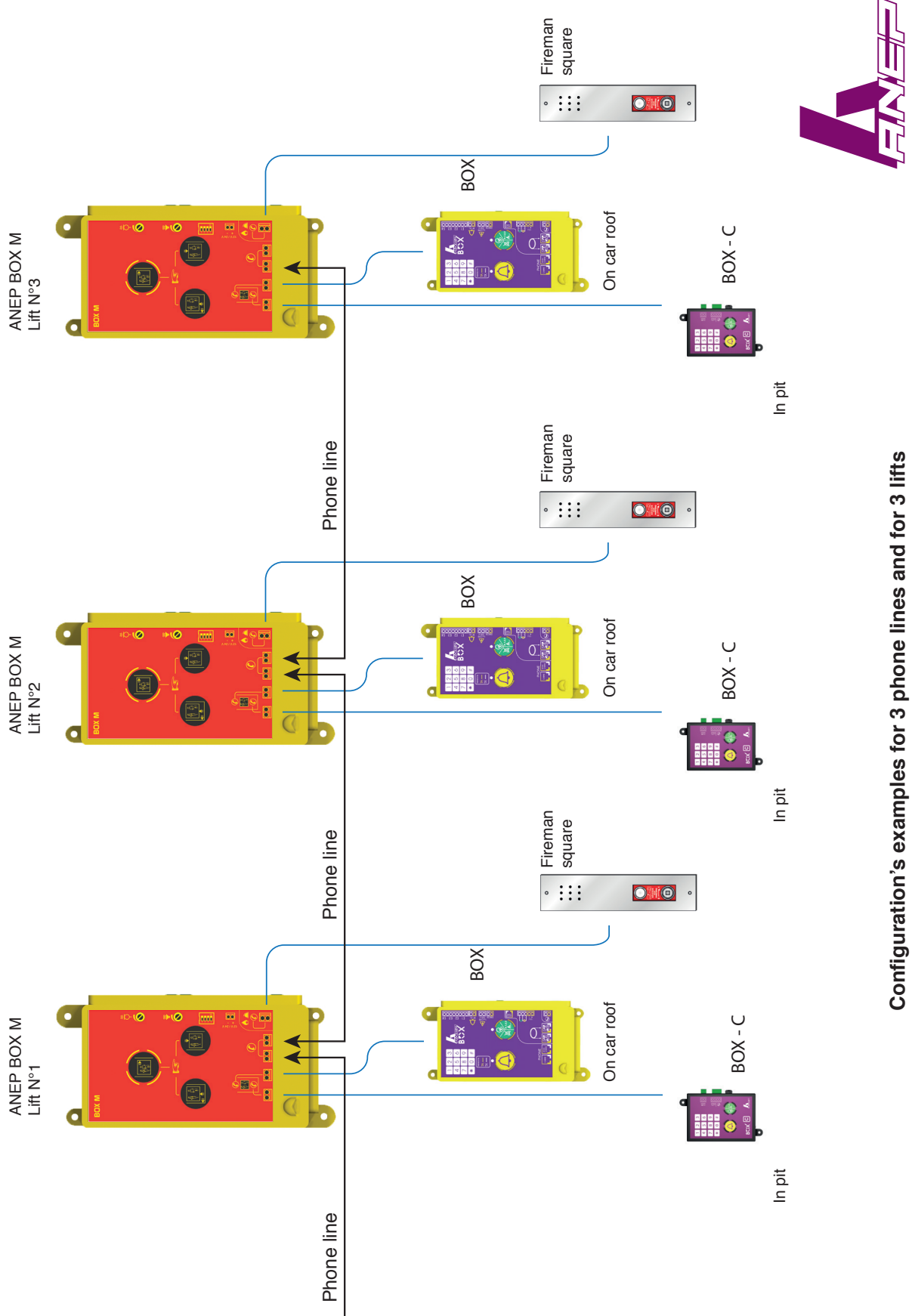

Configuration's examples for 3 phone lines and for 3 lifts

3 - INTERCOM FUNCTIONS

3.1 - Box M module volume adjustment



Box M loudspeaker volume



Box M microphone gain

3.2 - Machine room / car intercom

Pressing « Car Intercom » button of BOX M module establishes the vocal communication with the people inside the car.

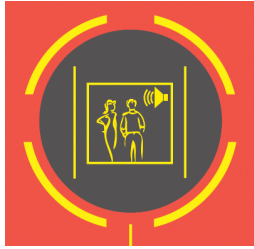

Once the communication is established, pressing BOX M module « car intercom » button activates the BOX M microphone and deactivate the sound of loudspeaker microphone (alternate).

Release the button allows to listen from the top of car for a period of about 25 seconds (Time Out). Each press on the button resets the playing time, time is running while releasing the button.

Once the running time has elapsed, the M BOX module free communication with the TA, TX or TX + BOX.

3.3 - Machine room / top of car intercom

Pressing « Intercom top of car » BOX M module button , establishes voice communication with the module installed on elevator car roof, enables voice communication with mechanic located on top of car.

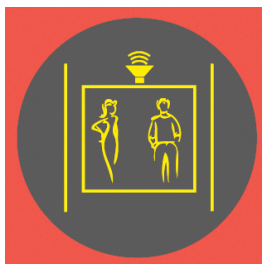

3.4 - Machine room / under car or pit intercom

Pressing Box M module «Intercom under car/pit» button, establishes voice communication with module installed either under car either with BOX-C installed in pit, enables voice communication with mechanic standing under the lift.



4 - Fireman square/lift car Intercom

Fireman intercom is functioning while activating «Fireman Square».
It must be connected with the corresponding input of Box M module, enables to communicate alternate with the lift car.

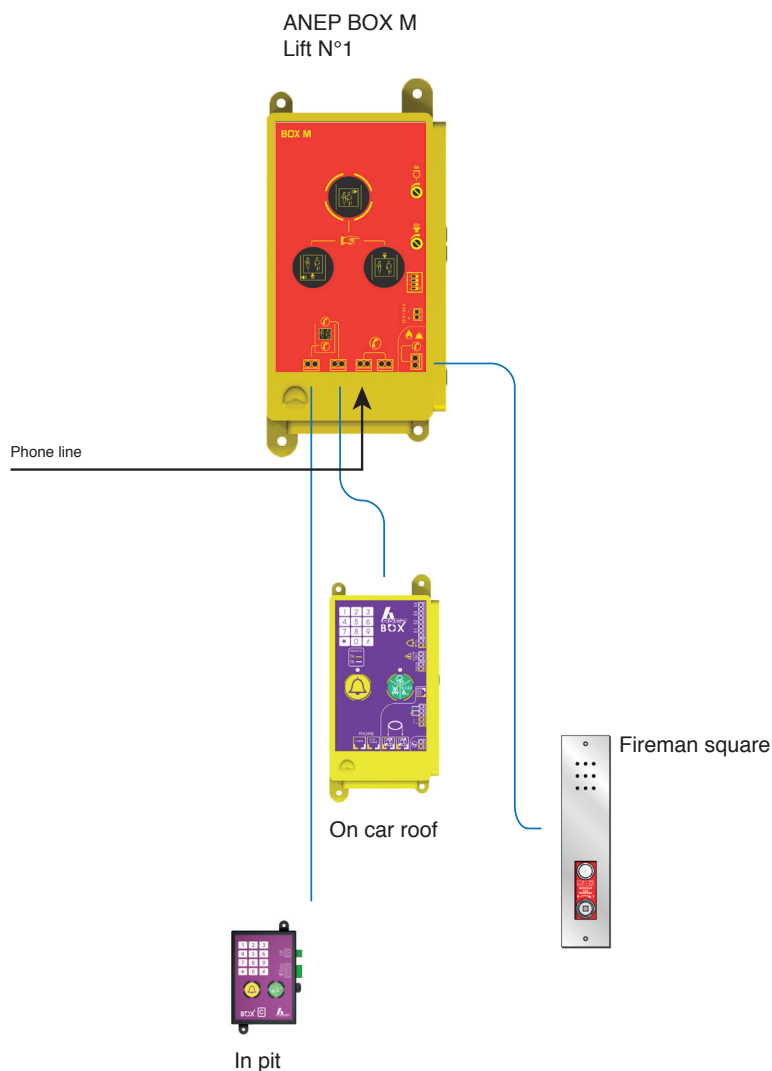

4.1 - Fireman Square

Activation of Fireman square establishes voice communication between firefighter at main landing and the person(s) inside the car lift.

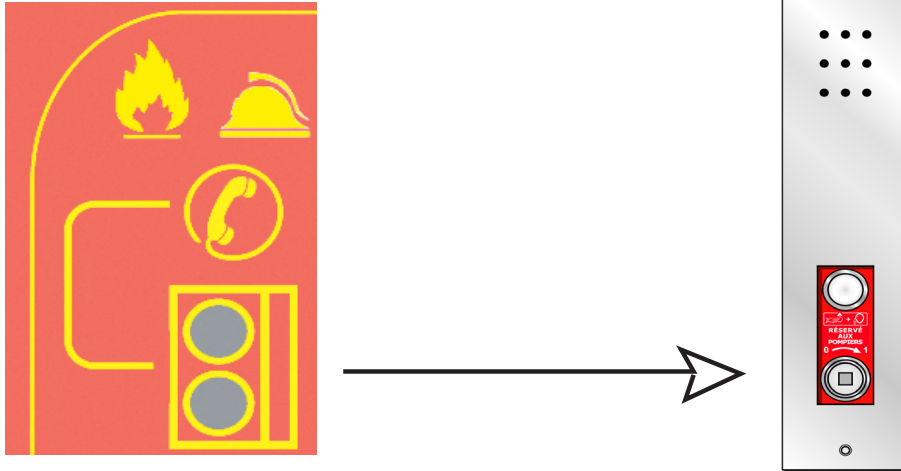

The «Fireman square/car» communication has priority over all ongoing communications; firefighter communication will be established in all cases.

Once the firefighter intercom set, pressing the button «Firefighter Intercom» activates the microphone module and cuts the firefighter speaker (alternate).

The «Firefighter Square» has a double contacts (NO and NC) enables to:

- Give the order to controller to move back the car to desired level (firefighter recall)
- To activate the intercom with the cab.

Taking into account the information of the NO/NC key switch, fire detection is done on the state of the loop, when connecting to the Box -M.

The operation of the voice is done alternate : Push the button to talk ; release the button to activate firefighter loudspeaker.

The release of the line is done by running mode «time out.»

This «time out» is a term 1 mn 30s at the start of the call and is reset to 30 seconds each time you press the alternate push button.

At running mode «time out», and if the firefighter key is still engaged, pressing the alternate push button restarts the call. Return to the key rest position releases the line and deactivates the firefighter intercom.

The key that equips the firefighter square has 2 contacts. 1 contact is used by the firefighter square, the other contact is free and can be used by the installer for firefighter information to the lift controller . In manufacturing output, the NC contact is reserved for the installer. Considering that when turn it on, the Firefighter Square remembers the resting state of the contact, it is possible to reverse the wiring of the key and let the NO contact free for the installer.

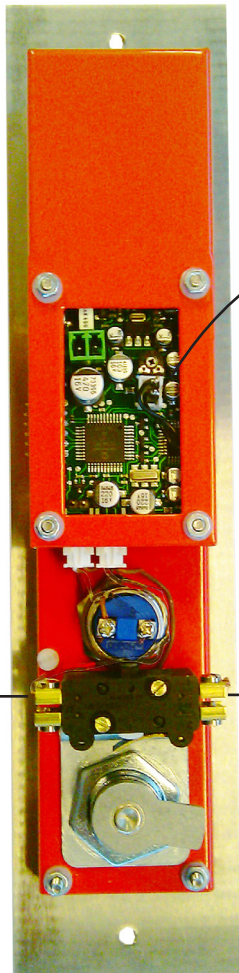

Contact for controller «fireman square» information

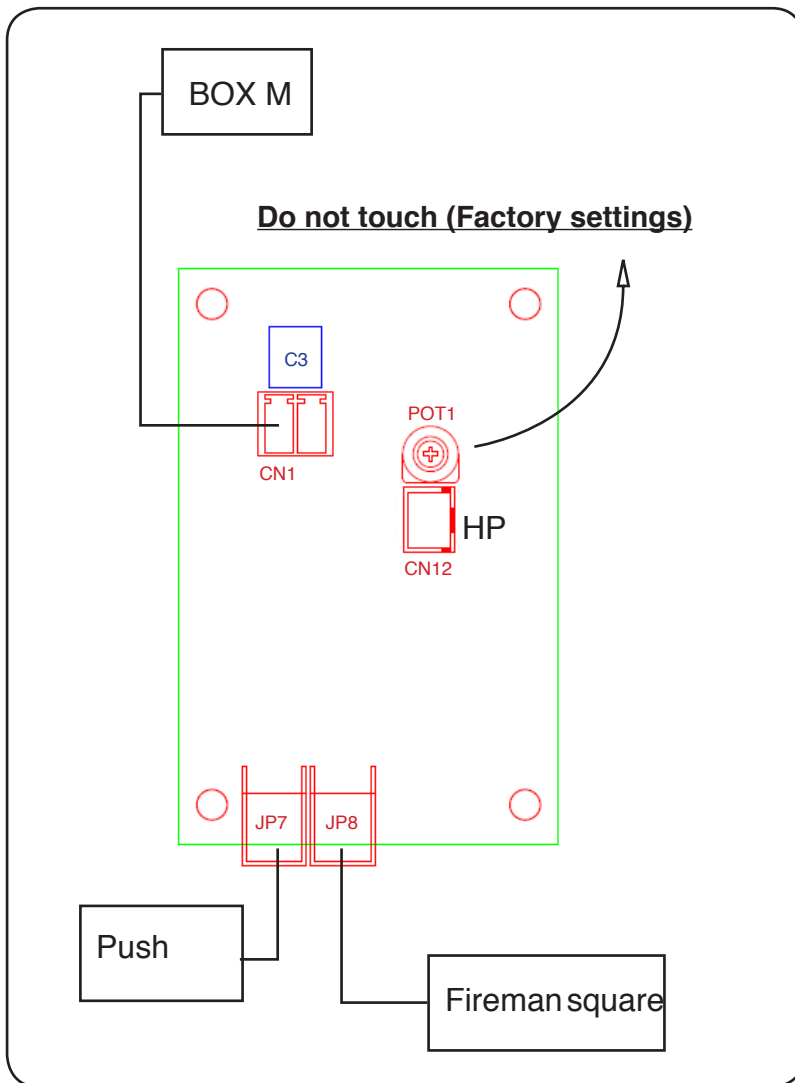

Factory Setting

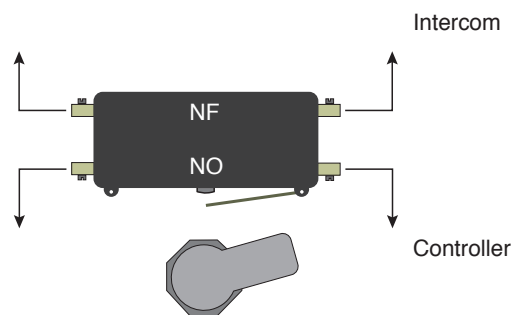
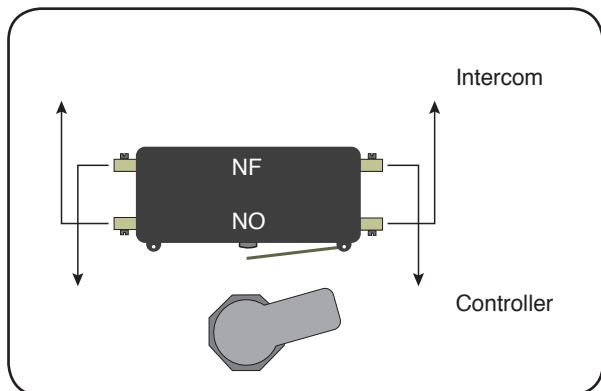

PROG :

/

ANEP BOX - M

DATE :

10

12

10

LE SERVICE APRÈS VENTE EST ASSURÉ PAR

SAVTEL

4 bis rue de Paris 94470 Boissy-Saint-Léger

Tel : 01 45 98 34 44

Fax : 01 45 69 75 45

Site internet : www.anepanywhere.com

