



PARACAÍDAS PROGRESIVO DYNATECH/
DYNATECH PROGRESSIVE SAFETY GEAR/
PARACHUTE À PRISE AMORTIE DYNATECH/
BREMSFANGVORRICHTUNG DYNATECH/

ASG-221-UD/ ASG-221

INSTRUCCIONES DE USO Y MANUTENCIÓN/
INSTRUCTIONS FOR USE AND MAINTENANCE/
INSTRUCTIONS D'USAGE ET ENTRETIEN/
GEBRAUCHS- UND WARTUNGSANLEITUNG/

REVISION	04	DATE	20/10/2020	PRODUCED BY / APPROVED BY	J.A.Torrubia/O. Lacámara
SECTION	DESCRIPTION				EFFECTIVE DATE OF CHANGE
4.3	Explanatory note is added				Not applicable
7	Annex section is added				Not applicable
REVISION	03	DATE	20/07/2020	PRODUCED BY / APPROVED BY	J.A.Torrubia/O. Lacámara
SECTION	DESCRIPTION				EFFECTIVE DATE OF CHANGE
-	The certificate number according to the UNE-EN 81-20, UNE-EN 81-50 and 2014/33/EU Directive is included				Not applicable
REVISION	02	DATE	17/07/2017	PRODUCED BY / APPROVED BY	P. Hernandez/O. Lacámara
SECTION	DESCRIPTION				EFFECTIVE DATE OF CHANGE
2.2	Paragraph content modified				Not applicable
REVISION	01	DATE	15/04/2016	PRODUCED BY / APPROVED BY	P. Hernandez/J. Marco
SECTION	DESCRIPTION				EFFECTIVE DATE OF CHANGE
2.1	The safety gear identification label is updated according to the 2014/33/EU Directive				20/04/2016
-	The certificate number according to the UNE-EN 81-20, UNE-EN 81-50 and 2014/33/EU Directive is included				Not applicable
6	The general plan is updated				Not applicable



ATISAE

EU TYPE-EXAMINATION CERTIFICATE

According to annex IV part A of Directive 2014/33/EU

Certificate number:	ATI / PP / 011	rev: 2
Notified Body:	TÜV SÜD ATISAE S.A.U. Avda. de los Artesanos, 20 E 28760 Tres Cantos MADRID (ESPAÑA) Identification number: 0053 .	
Product:	Safety Component Progressive Safety Gear (PP)	
Type:	ASG-221 / ASG-221 UD	
Manufacturer:	DYNATECH, DYNAMICS & TECHNOLOGY, S.L.U. P.I. PINA DE EBRO, SECTOR C PARCELA 9 50750 ZARAGOZA	
Certificate Holder:	DYNATECH, DYNAMICS & TECHNOLOGY, S.L.U. P.I. PINA DE EBRO, SECTOR C PARCELA 9 50750 ZARAGOZA	
Date of submission:	29.06.2020	
Date of type examination:	08.07.2020	
Test laboratory & report:	Please refer to tech. annex section 2.10.	
Directive:	Directive 2014/33/EU of 26 February 2014	
Standards of reference:	EN 81-20:2014; EN 81-50:2014;	
Report number:	8101277506 (23.06.2020); MD_DEU_150307 (30.01.2015);	
Expiry date:	Indefinite. Please refer to tech. annex section 2.12)	
Statement:	The safety component allows the lift on which it is installed to satisfy the health and safety requirements of the Lifts Directive when it is used within the scope, as well as under the installation conditions that are set up in the technical annex to this certificate. This certificate consists of this cover, a technical annex with 3 pages and 2 enclosed documents. It shall be reproduced with all its pages and documents to be considered valid.	



DAS/0000018-1

Bruno Cano Hernández
Director Técnico de Elevación

TÜV SÜD ATISAE S.A. (Unipersonal) (Áreas territoriales: Madrid, Castilla y León, Cantabria, Galicia, Logroño, Cataluña, Tenerife, Murcia, Mérida, Asturias, Pamplona, Valencia, Vitoria y Zaragoza). Organismo de Control acreditado por ENAC con acreditación nº 05 / EI 730.

EC12.04F4-EN v.2019-01-31

GENERAL CONDITIONS – INFORMATION TO THE CERTIFICATE HOLDER

- ❖ This certificate is the means to assure the compliance with the procedure for assessing the design phase for the safety component according to clause 15.1.a) or b) of the European Lift Directive 2014/33/EU.
- ❖ In order to place the component into the market, the manufacturer shall comply with any of the assessment procedures mentioned in that clause to assess the production phase.
- ❖ The holder and the manufacturer of the component shall follow the obligations described in clause 8 of the Lift Directive.
- ❖ The CE marking of the component shall follow the rules described by clauses 18 and 19 of the Directive, and must be accompanied by the number of the Notified Body intervening in the assessment of the production phase (clause 19.4).
- ❖ This certificate is issued in order to make it publicly available, so the holder may be required to deliver a copy to check the technical specifications. In such a case it shall be delivered or reproduced completely with all its pages and drawings.
- ❖ If the certificate is extended the certificate number will remain, being modified only the revision number.
- ❖ In the event of end of production for the component, the holder shall inform to this Body the effective date when the component is not available to place it into the market.

These conditions are for information only and are not part of the certificate body.

TECHNICAL ANNEX TO THE EU TYPE EXAMINATION CERTIFICATE ATI / PP / 011 Rev. 2

1. Scope:

1.1. Progressive safety gear (free fall or descending overspeed).

TYPE	Guide rail	Blade width (mm)	Permissible mass (kg)	Vr (m/s)	Vt (m/s)	A.F. (mm)	Oiling condition
ASG-221/ASG-221 UD	B	7 ÷ 16	754 ÷ 3,284	3.40	3.90	≥25	dry

key: B (machined); Vr maximum rated speed (please refer to remark 2.8);
Vt maximum tripping speed; AF gripping width;

1.2. ACOP Braking device (ascending overspeed).

TYPE	Guide rail	Blade width (mm)	Braking force (N)	Vr (m/s)	Vt (m/s)	A.F. (mm)	Oiling condition
ASG-221 UD	B	7 ÷ 16	8,724 ÷ 30,792	3.40	3.90	≥25	dry

Key and remarks (please refer to section 1.1.)

1.3. Adjustment:

continuous;

1.4. Activation means.

In addition to conventional tripping means, using the governor's rope, the following types are supported to be used along with so called electronic overspeed governors (please refer to the mentioned certificates for conditions and details):

Type	certificate	For safety gear types
DA (eASG)	ATI / CA 020	ASG-221
DA-UD (eASG UD)	ATI / CA 021	ASG-221 UD

2. Remarks.

General remark. All clauses mentioned with reference to EN 81-20, unless otherwise indicated.

- 2.1. Intended use of the device. The safety gear device can be used as means against the free fall and descending overspeed [5.6.2.1], as braking device for the ascending car overspeed protection means [5.6.6.4.a)] or as stopping element for a protection against unintended car movement system [5.6.7.4.a)] (see remark 2.14). In these both cases it only represents a part of the means or system. For [5.6.2.1] and [5.6.6], an overspeed governor as set forth [5.6.2.2.1] and [5.6.6.10.a)], or equivalent means, shall be used to control the speed of the car. For [5.6.7] an additional system shall control and detect the unintended movement of the car and trigger the stopping element.
- 2.2. The arrangement of the device makes available, in one single block, the braking performance for both directions (downwards / upwards). The figures of permissible mass (1.1) and braking force (1.2.) when used as braking device are related, because of the device uses the same adjustment for both in one single elastic element so they cannot be adjusted separately.
- 2.3. There are two sub-types: one available for up and down tripping (marked UD) and other only to be tripped downwards which upwards tripping roller has been disengaged.



- 2.4. The certificate affects to the gripping elements and does not include either the connection elements, safety gear rods, or the actuation of the electric safety device, except for the activation sets: DA & DA-UD.
- 2.5. When the device is used as braking device against ascending overspeed [5.6.6], the permissible braking force of the device shall be used in such a way that the retardation of the car does not exceed 1 gn with empty car moving upwards. The responsibility to comply with this premise is under the installer of the lift. Furthermore, the retardation must be enough to achieve the counterweight hits its buffers at a speed not higher than the rated speed.
- 2.6. When the device is used as stopping element [5.6.7], the permissible braking force of the device shall be used in such a way that the retardation of the car does not exceed 1 gn with empty car moving upwards. The responsibility to comply with this premise is under the installer of the lift. Furthermore, the retardation must be enough to achieve the car to be stopped within the stopping distance set forth in [5.6.7.5]. This last premise shall also be ensured for the descending stopping distance.
- 2.7. The mass stated may differ from the permissible mass by 7.5 %.
- 2.8. This device must be used according the conditions given in EN 81-20. The rated speed in section 1.1 is the maximum permissible but should be considered what stated in [5.6.2.2.1.1.a)4)] regarding the recommended tripping speed for a given rated speed when it is greater than 1.0 m/s.
- 2.9. It shall be placed an identifiable plate on the device with the following items:

Manufacturer's name	Type-examination certificate number ⁽¹⁾
Permissible load range or adjustment parameter ⁽²⁾	Guide rail type for which the device is adapted ⁽³⁾

- (1) The marking of the device is done as part of the protection system to which it belongs (please see 2.1 and 2.14). The CE marking shall only be considered for the part concerning the means of protection against free fall [5.6.2.1] and against ascending car over-speed [5.6.6].
- (2) In case the marking of the device shows the adjustment parameter instead of the load range, it shall be made available in the instruction manual the relation between this parameter and the load range.
- (3) In order to adapt the device to different blade widths there are constructive differences. The marking shall include either the guide rail type (by its reference) either the blade rail width for which the device is adapted.

Additionally, the nature of the safety gear for only down tripping or up & down tripping shall be stated.

2.10. Test laboratory.	Test report
LABORATORIO DE ENSAYO DE COMPOENTES DE ASCENSORES (L.E.C.A.) E.T.S. Ingenieros Industriales. U.P.M. C/ José Gutierrez Abascal, 2 28006 MADRID	2014-011-M1 (14.01.2015)

2.11. The following documents are enclosed to this certificate:

NUMBER	DATE	TITLE
DYN 38.C001.01	28/03/2006	CONJUNTO ASG
DYN 38.C001.02	12/02/2009	CONJUNTO ASG UD

These documents are enclosed in order to provide identification and information about the basic design of the safety component.



- 2.12.** This certificate has not an expiry date except in case of: design modifications, that the manufacturer must communicate to this Notified Body previously to the modifications be effective; changes in the applicable legislation or technical changes in the standards of reference for which the expiry date shall be the deadline provided by the regulation, or the date when the standard of reference ceases to provide presumption of conformity.
- 2.13.** This certificate is the adaptation of the certificate with number ATI/LD-VA/M215/15 issued on 30.01.2015 by ATISAE, to the standards with references EN 81-20 and EN 81-50. The component is the same so it can be used in the event of replacing.
- 2.14.** The mention to its use as stopping element within the protection system against unintended car movement (UCM) is done with the basis of the provisions given by EN 81-20.

Regarding the use of the device as stopping element it should be noted:

- a) The stopping ability of the device has been tested at different speeds, including at low speed so a braking force able to stop the car can be achieved. It is not possible to provide a single stopping distance because this is a function of the characteristics of the hoisting layout and the speed reached when the braking starts.
- b) There is no evidence that the device can keep the braking force along the range of possible tripping speeds. It can be stronger or softer braking which shall be assessed when testing the complete UCM system.
- c) The ratio of P/Q and other characteristics related to the scope as stopping element shall be found via tests of the whole assembly of the UCM system.

2.15. Revision log.

REV	Date	Modification
0	21.07.2015	Initial issue.
1	21.04.2016	Updating of references to Directive 2014/33/EU.
2	08.07.2020	Includes electromechanical activation means used along with electronic overspeed governors.



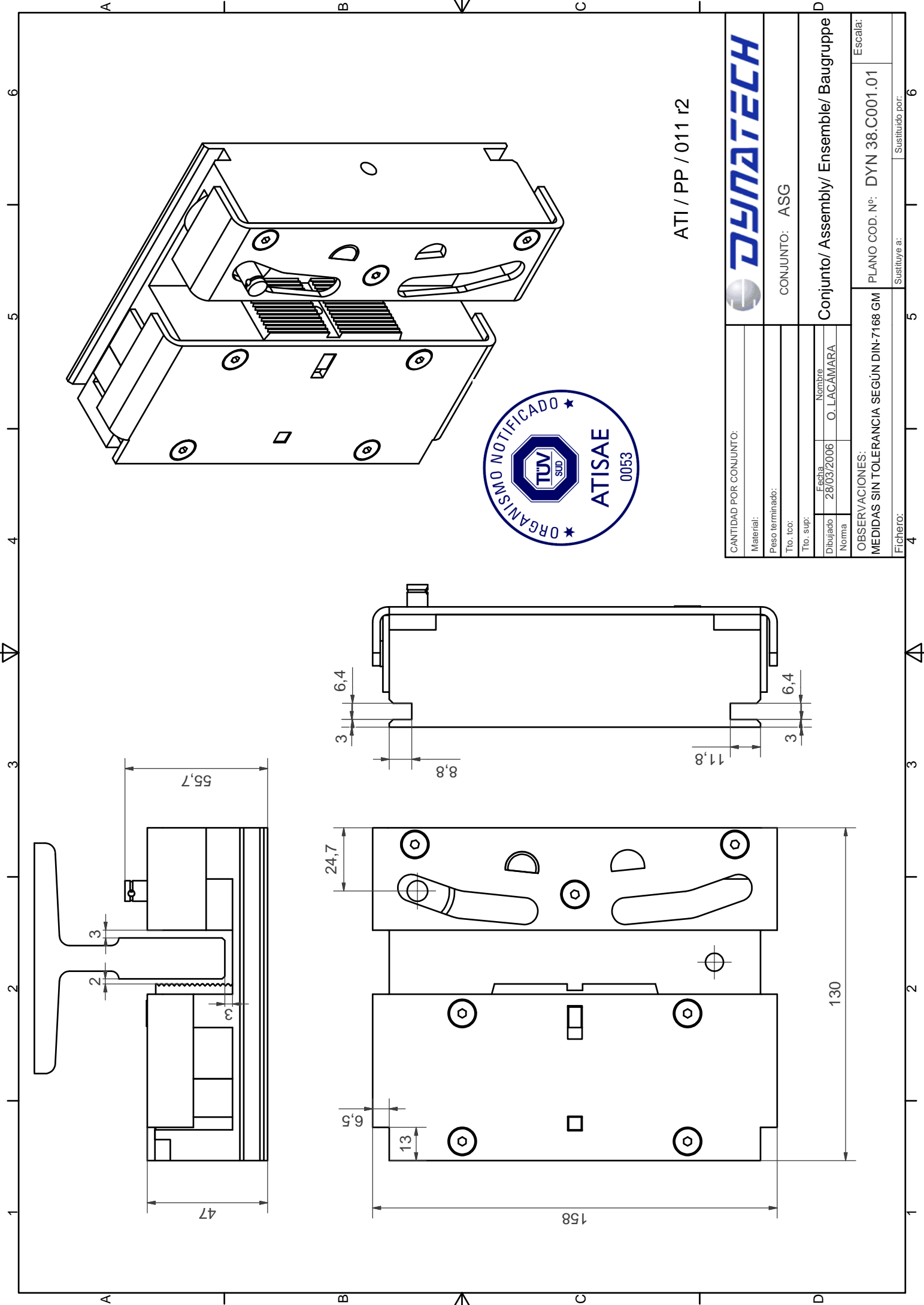

A

B

C

D

6

5

4

3

2

1

A

B

C

D

6

5

4

3

2

1

ATI / PP / 011 r2



CANTIDAD POR CONJUNTO:
 Material:
 Peso terminado:
 Tto. tco:
 Tto. sup:

CONJUNTO: ASG

Conjunto/ Assembly/ Ensemble/ Baugruppe

Dibujado	Fecha	Nombre
28/03/2006	28/03/2006	O. LACÁMARA
Norma		

OBSERVACIONES:
 MEDIDAS SIN TOLERANCIA SEGÚN DIN-7168 GM

PLANO COD. N°: DYN 38.C001.01
 Escala:
 Fichero: Sustituye a:

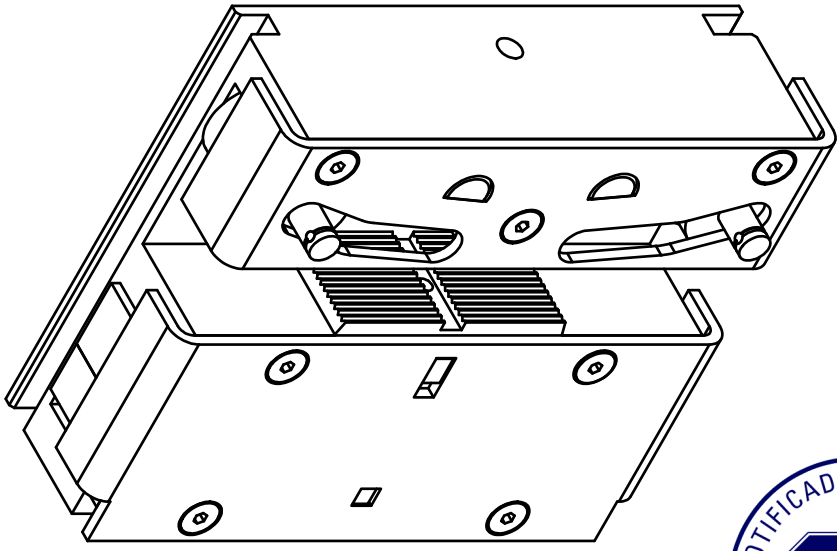

ATI / PP / 011 r2



CANTIDAD POR CONJUNTO:		DYNATECH	
Material:		CONJUNTO: ASG UD	
Peso terminado:		Conjunto/ Assembly/ Ensemble/ Baugruppe	
Tto. tco:		Escala: PLANO COD. Nº: DYN 32.C001.02	
Tto. sup:	Fecha	Nombre	Observaciones:
	12/02/2009	J. Remacha	MEDIDAS SIN TOLERANCIA SEGÚN DIN-7168 GM
Dibujado	Fichero:		
Norma	Sustituye a:		

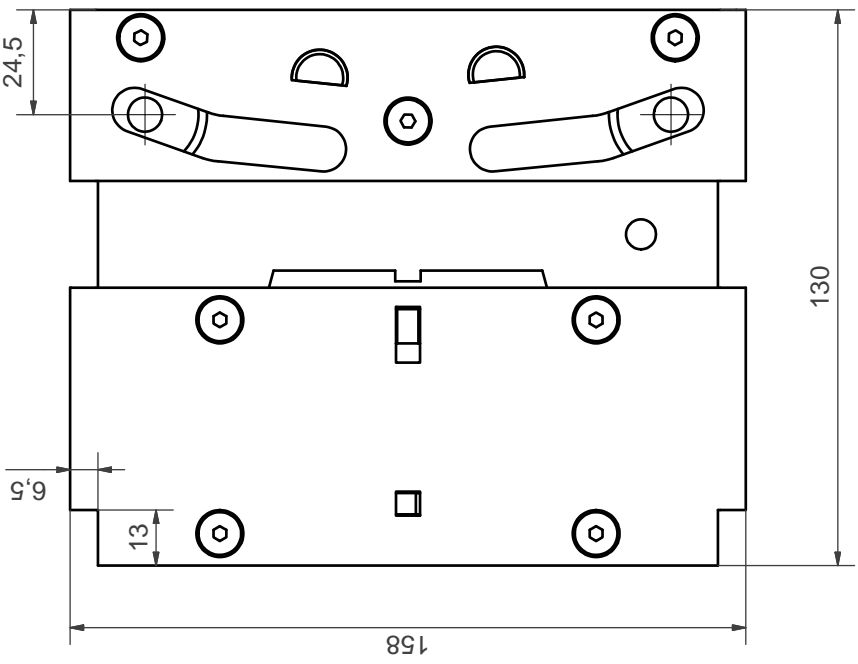
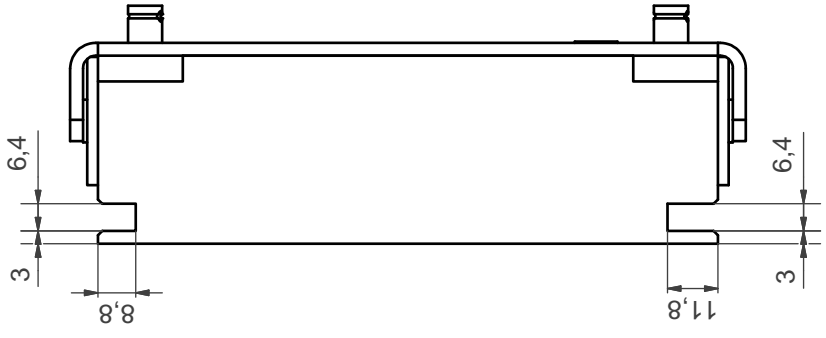
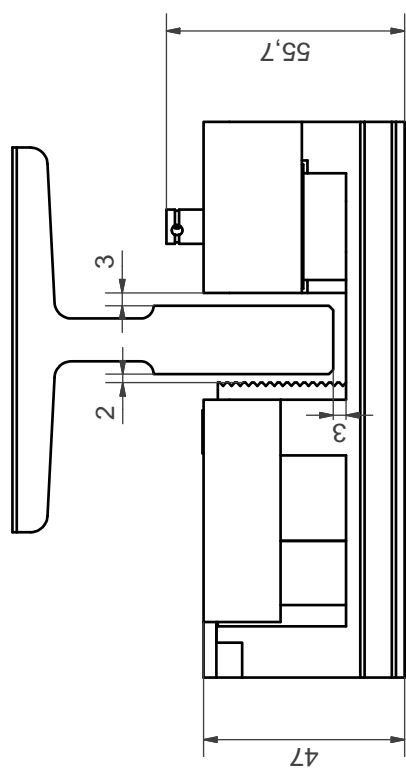

INSTRUCTIONS FOR USE AND MAINTENANCE

1	GENERAL INSTRUCTIONS	3
2	SAFETY GEAR IDENTIFICATION AND CHARACTERISATION	3
2.1	IDENTIFICATION	3
2.2	SAFETY GEAR'S FEATURES AND USE.....	3
2.3	RANGE OF USE	4
3	INSTALLATION AND ADJUSTMENT	4
3.1	ASSEMBLY ON FRAME WITH T-25 UD/T-25 DRIVING BAR	4
3.2	SAFETY GEAR ADJUSTMENT	7
3.2.1	ON SITE ADJUSTMENT	8
3.3	SAFETY GEAR INSTALLATION WITH OTHER DRIVING BARS	9
4	INSPECTIONS AND MAINTENANCE	10
4.1	CHECKING THE SAFETY GEARS	10
4.2	PRECAUTIONS	10
4.3	MAINTENANCE.....	10
4.3.1	LIST OF MAINTENANCE OPERATIONS	10
4.3.2	CORROSION.....	11
4.4	STORAGE AND SERVICE LIFE	11
5	UCM	11
5.1	UCM SYSTEM'S PRELIMINARY DESIGN	11
5.2	SAFETY GEAR BRAKING DISTANCE CALCULATION	12
6	GENERAL DRAWING	12
7	ANNEXES	13

1 GENERAL INSTRUCTIONS

Each pair of safety gears supplied is factory tared according to the required conditions of use: Total mass (P+Q) and guide rails' thickness. These features are indelibly displayed, along with the standardisation password and serial number; on the protection plates on top of the safety gear boxes (see section 2.1).

It is strictly forbidden:

- To combine and assemble safety gear boxes with different serial numbers.
- To use a pair of safety gears for installations with characteristics different from those indicated on that pair of safety gears' protection plates.
- To handle any of the safety gear's components.

DYNATECH DYNAMICS & TECHNOLOGY, S.L. cannot be held responsible for the damage caused due to the non-observance of any of these general instructions.

2 SAFETY GEAR IDENTIFICATION AND CHARACTERISATION

2.1 IDENTIFICATION

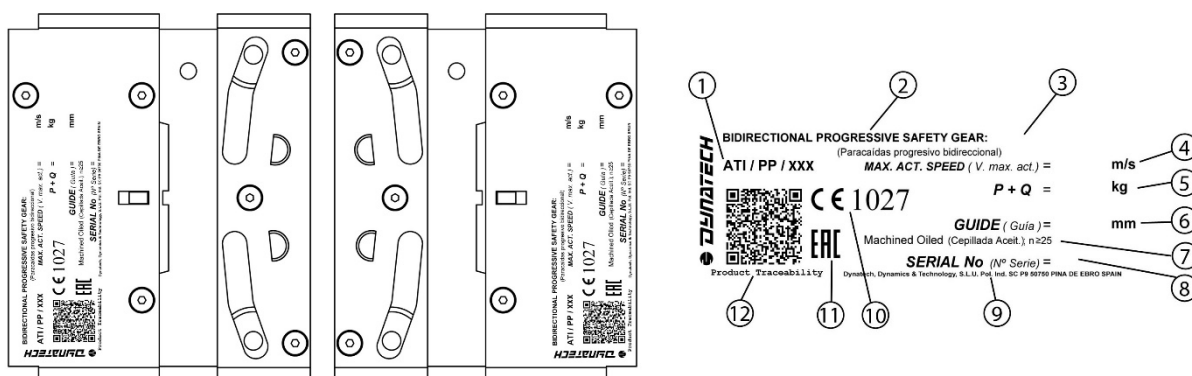

SAFETY GEAR IDENTIFICATION LABEL			
1	EU type examination certificate number	7	Guide rail type
2	Safety gear type	8	Safety gear serial number
3	Safety gear model	9	Dynatech address
4	Safety gears' maximum tripping speed (m/s)	10	Quality assurance CE marking and notified body number
5	Total load (Kg)	11	Marking for market access to member states of the Customs Union
6	Guide rail thickness (mm)	12	QR product traceability code

Figure 1: Safety gear identification

2.2 SAFETY GEAR'S FEATURES AND USE

- The guide rails to be used should be machined and dry for ASG 221 and ASG-221 UD models. Allowable tolerances for guide rail thickness should be within the limits set by the standard: ISO 7465:2007.

SUMMARY TABLE

MODEL	ASG-221/ASG-221 UD
TYPE OF GUIDE RAIL	MACHINED
LUBRICATION	DRY

- There is a bidirectional ("UD") and a unidirectional version for each safety gear model.
- This safety gear can be applied at a speed of action from 2.33 m/s to 3.9 m/s.
- Allowable guide rail thicknesses: 7 – 16 mm.
- The guide rail braking surface should be greater than or equal to 25mm.

2.3 RANGE OF USE

Please find below the standard P+Q table. The rated values are displayed in bold in the middle row. The safety gears, when supplied, are set to the default rated value; however, they can be used in installations with P+Q values within the upper and lower limits.

ASG 221 UD/ ASG-221

Lower limit	P+Q (Kg.)	Upper limit
698	754	810
788	852	916
912	986	1060
1038	1122	1206
1152	1246	1339
1290	1394	1499
1450	1567	1685
1615	1746	1877
1717	1856	1995
1962	2121	2280
2108	2279	2450
2297	2483	2669
2476	2676	2877
2654	2869	3084
3038	3284	

As an added safety factor, Dynatech recommends the maximum (P+Q) value of 3284kg is not exceeded when the safety gear is installed.

Loads may be duplicated through configuration of this tandem safety gear. See Manual DYN 37/8 – Extendible T25UD/T25 Tandem safety gear for further information.

3 INSTALLATION AND ADJUSTMENT

3.1 ASSEMBLY ON FRAME WITH T-25 UD/T-25 DRIVING BAR

ASG UD/ASG safety gears are pre-assembled in factory with a T-25 UD/T-25 driving bar. These safety gears are attached to the frame by using T-25 UD/T-25 driving bars. This driving bar ensures that the safety gear pairs are synchronised.

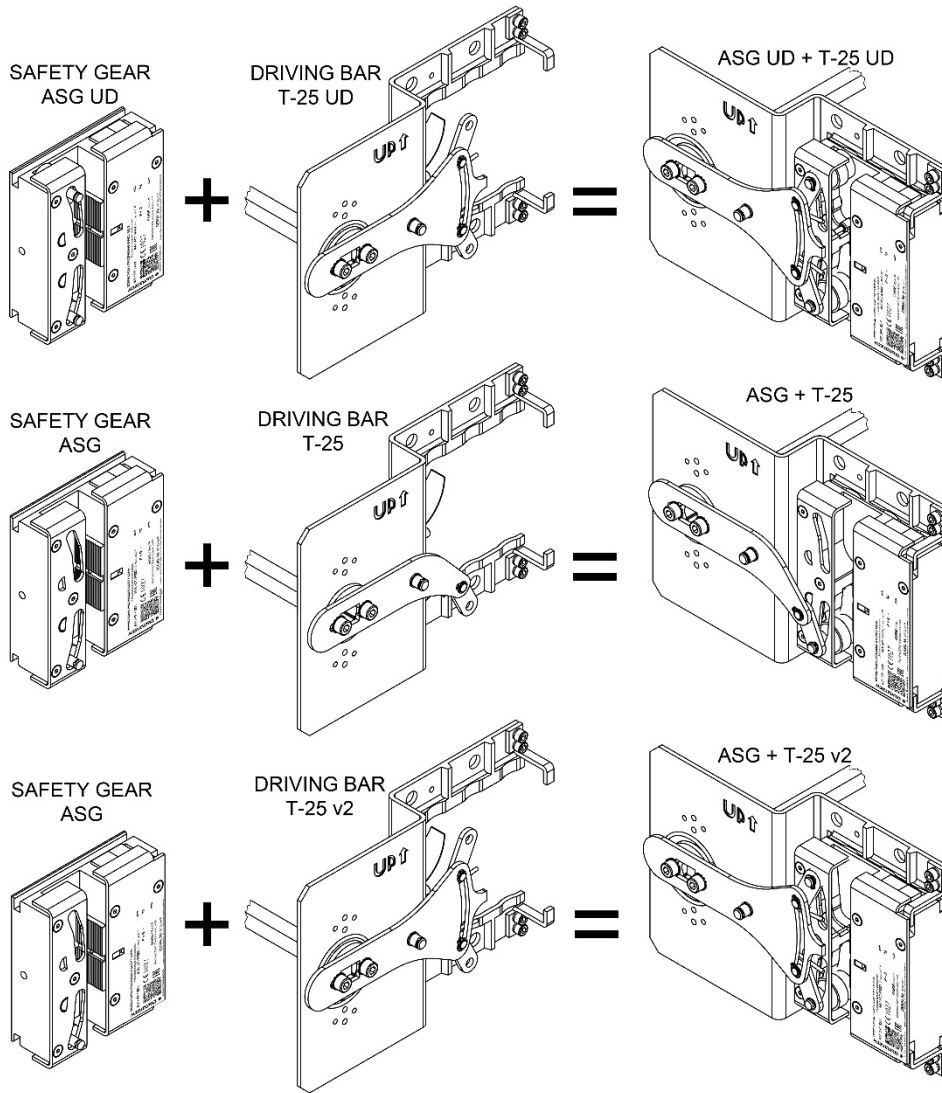

Figure 2: ASG UD/ASG Safety gear and T-25 UD/T-25 Driving bar

The holes for attaching the driving bar should be made on the frame uprights according to the dimensions and the position displayed in the drawings included in the T-25 UD/T-25: DYN 37 – T-25 UD/T-25 driving bar assembly manual, thus ensuring that the guide rail's axis is centred with the frame.

To secure the safety gear onto the frame, we recommend a 79.09 Nm tightening torque for grade 8.8 M12 bolts, and of 111 Nm for grade 10.9 bolts.

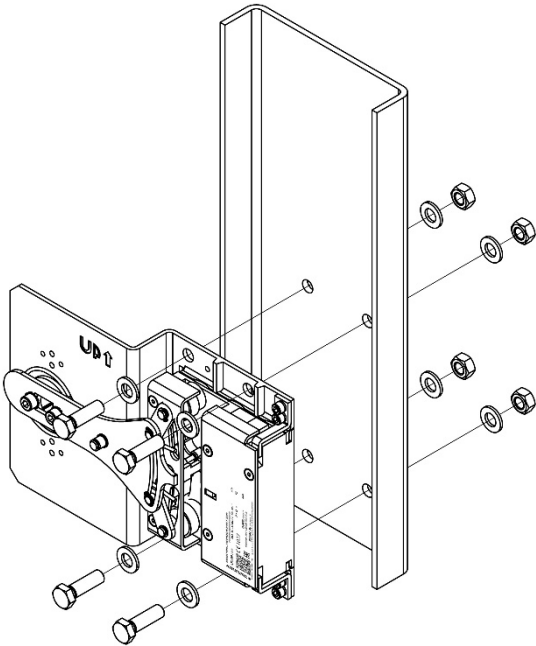

Figure 3: Assembling the safety gear onto the frame (1)

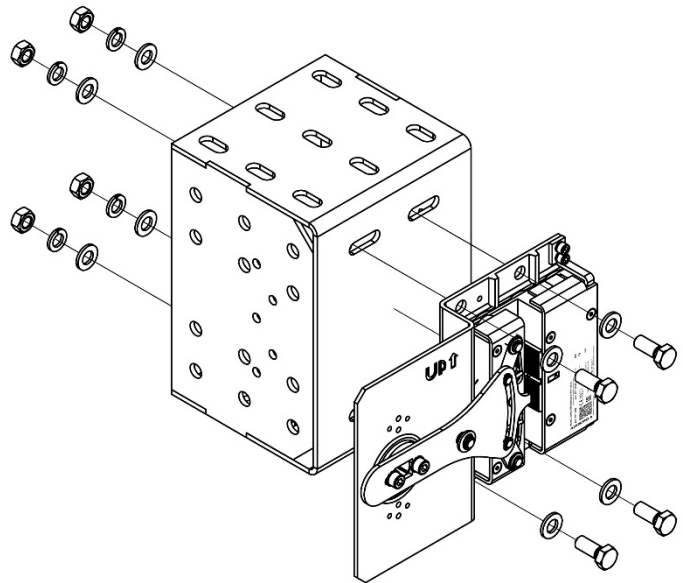

Figure 4: Assembling the safety gear onto the frame (2)



Safety gear position:

- a) The safety gears should be assembled in the position displayed in Figure 55
- b) A circle located on the safety gear's centre will indicate its upper part. This mark should always be on the upper part during the assembly.
- c) There should be an additional mark on the driving bar including the word "UP" and an arrow indicating the safety gears and driving bar's upright position.

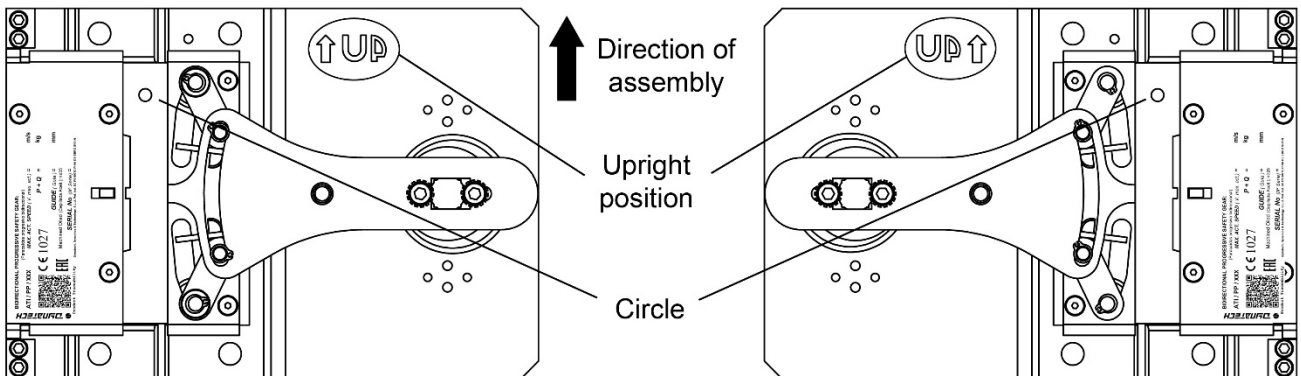

Figure 5: Direction of assembly

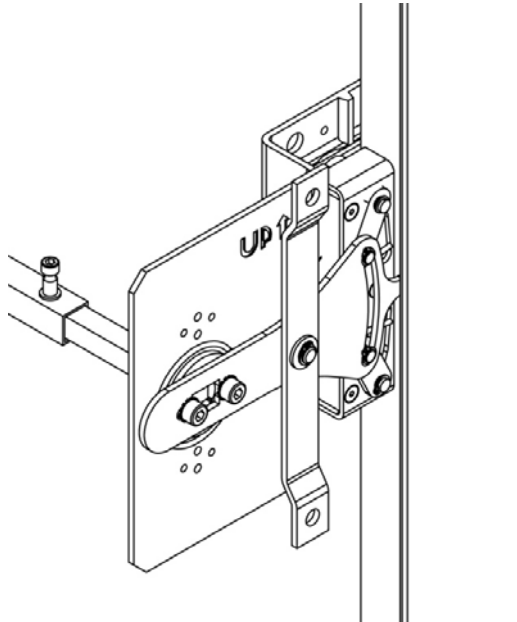

Figure 6: Roller position

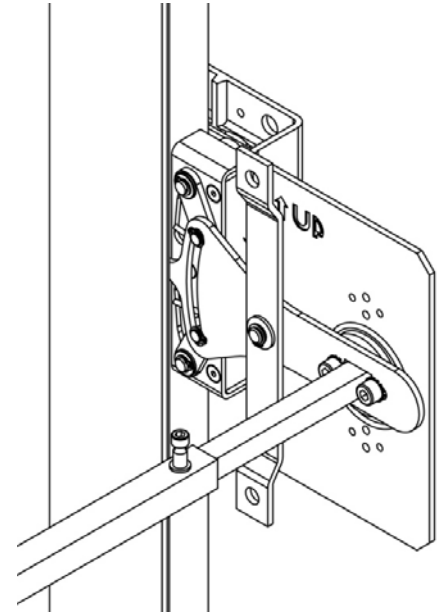

Figure 7: Roller position on inverted guide rails

During assembly, the safety gear should be perfectly aligned with the guide rails, both vertically and horizontally. Improper assembly may cause the safety gear to function incorrectly.

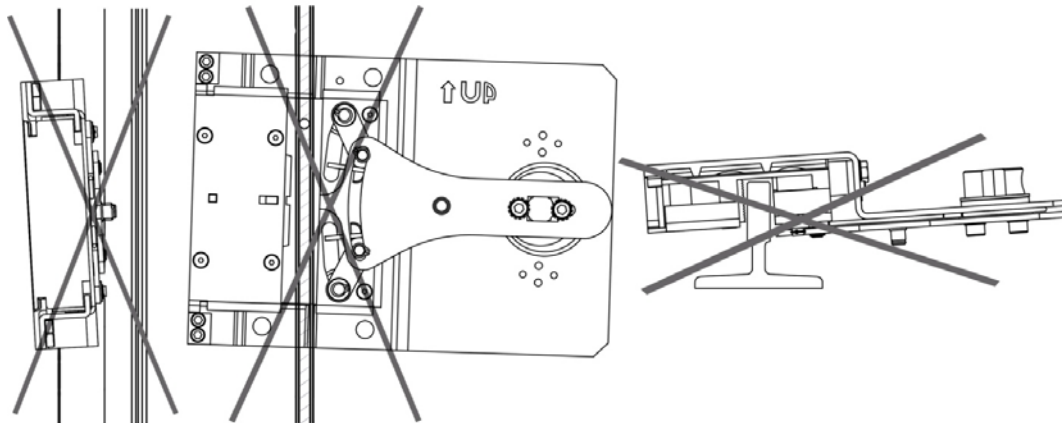

Figure 8: Improper assembly

For more information concerning T-25 UD/T-25 driving bar assembly, please consult its manual: DYN 37 - T-25 UD/ T-25 Driving bar.

It is not recommended to exceed a maximum force of 1900 N is not recommended with the governor.

3.2 SAFETY GEAR ADJUSTMENT

The guide rail's position in the block should be adjusted as follows: The side of the guide rail 2 mm from the brake shoe; the head of the guide rail 3 mm from the back of the groove (see drawing DYN 32.C001.02/DYN 38.C001.01).

In order to avoid problems with the installation's normal operation, it is very important that the person carrying out the installation rigorously observes the distances mentioned in this item.

Please make sure that the safety gear is placed so that the circle on the safety gear, the word "UP" and the arrow on the driving bar's plate are on the upper part, as displayed in section 3.1.

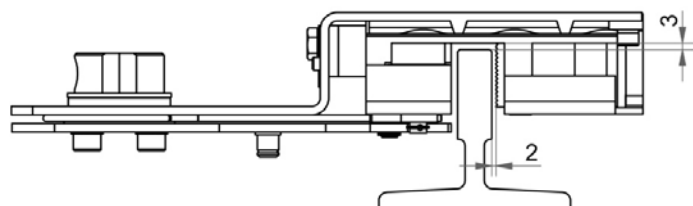



Figure 9 Safety gear adjustment in relation to the guide rail

3.2.1 ON SITE ADJUSTMENT

On-site adjustment is an option for the ASG series safety gear models. It is used where the distance between the safety gear and the guide rail must be adjusted during installation. This adjustment will be made if any part of the safety gear makes contact with the guide rail. The block movement should not exceed 2mm after this adjustment.

 The purpose of the in-situ control is to correct for any rubbing of the safety gear against the guide rail. This system is not designed to adjust the safety gear with respect to the guide rail centre. The safety gear adjustment is done by via the position of the holes on the frame, as explained in section 3.2 of this manual.

It is not factory-fitted and the components can be found in the small bag of nuts and bolts supplied with the safety gear.

This system consists of one DIN 933 M8x35 bolt (1) that adjusts the distance of the block as it is loosened or tightened and one DIN 463 M8 safety washer (2) that prevents the bolt from becoming loose once adjusted. The shoe will move towards the guide rail on tightening the bolt and will move away from the guide rail on loosening the bolt.

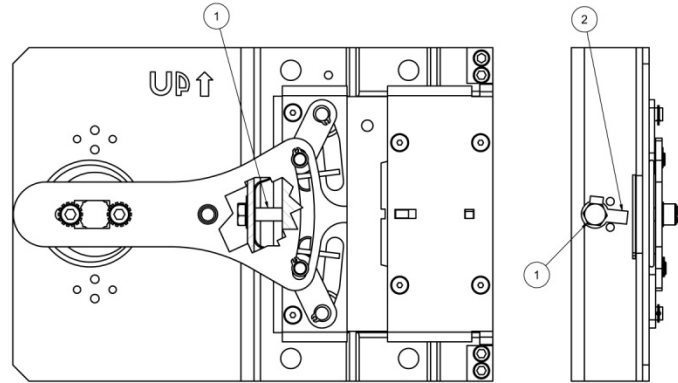

Figure 10: Layout of the on-site adjustment system inside the safety gear

Fitting

The system is extremely easy to fit, although minimum precautions are necessary. First check that the side rail where the ASG safety gear with the on-site adjustment system is fitted allows for the bolt to move freely, as it moves when the safety gear operates. Where necessary, modify the side rail to permit this movement.

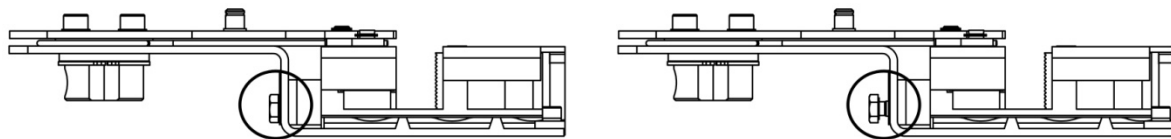

Figure 11: Movement of the bolt when the safety gear operates

Also check the head of the bolt can be accessed using the correct tool for adjustment.

The block should always be fitted at the distance recommended; the part of the block where the shoe is located must be at a distance of 2 mm from the guide rail side. If necessary, fit a gauge of the recommended thickness to ensure that the distance from the shoe to the guide rail is the appropriate one.

Fit the washer in the position indicated in Figure 12 and insert the bolt into the hole in the side of the safety gear. The longest tab of the washer must be placed between the strap attachment bolts.

It is factory-adjusted to the corresponding type of guide rail and, therefore, this system will solve any installation defect. Where the shoe is to be moved away from the guide rail, the DIN 912 M6x8 lock bolts (3) should be loosened to allow the block to move freely. When loosening, never remove the bolt fully as the block would become loose and have no end stop. Simply loosen until there is a certain amount of play with the block.

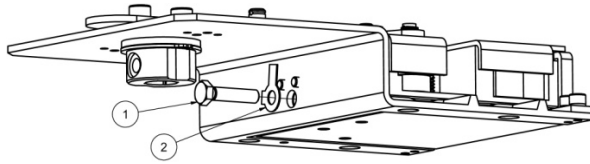

Figure 12: Fitting method

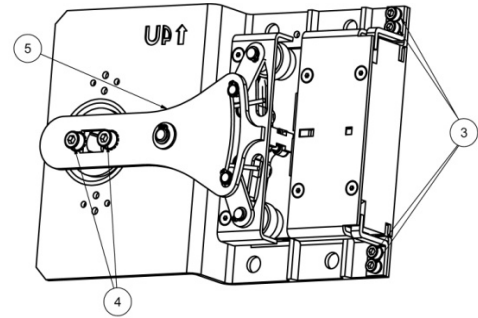

Figure 13: Loosening the attachment screws

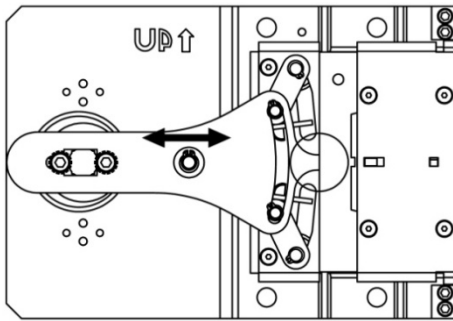

Figure 14: Adjusting the drive bar (5)

The DIN 912 M8x16screws (4) which attach the drive bar (5) to the rigging must also be loosened.

Once the adjustment is made via the on-site control system, the drive bar should be correctly positioned (5), by moving it until the tip of the drive bar is properly aligned with the safety gear block, as shown in Figure 14.

The DIN 912 M8x16 screws (4) are then tightened.

After adjusting to the appropriate distance, fully bend the flap on the DIN 463 M8 safety washer (2) to prevent the bolt from becoming loose and, as a result, the block from moving during normal frame operations.

! Re-tighten screws (3) if they have become loose.

Make sure the flap on the washer is bent after fitting the safety gear. Make sure that one of the flat sides of the bolt head is parallel to the washer flap to ensure it prevents the bolt from turning.

! Make especially sure that the bent flat is the shortest (see 014), as the other flap operates as a turn protection stop.

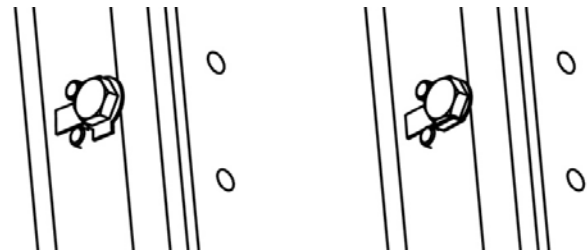

Figure 15: Bending the safety washer

To ensure the position of the screw, glue can be applied between the screw head and washer

The on-site adjustment system of the ASG UD/ASG model safety gear is now in place. The fitter is responsible for ensuring that the ASG UD/ASG safety gear and the T-25 UD/T25 linkage work properly after handling and that the frame is designed for this option

3.3 SAFETY GEAR INSTALLATION WITH OTHER DRIVING BARS

It is the responsibility of the person who installs the safety gear to properly position the driving bar in relation to the safety gear, as well as to properly synchronise the safety gears controlled by that driving bar.

Please keep in mind that part of the functions of these safety gears are performed by the T-25 UD/T-25 driving bar.

If another driving bar is adapted to be used with these safety gears, please keep in mind that this driving bar:

- Should allow the safety gear to move horizontally in relation to the guide rail.
- Should allow the rollers to return to their original position.
- Is responsible for attaching the safety gears to the frame.
- As an option, the safety gears may be regulated on site.
- Should incorporate an electrical safety contact.

All these characteristics should be guaranteed and Dynatech should approve the adapted driving bar's design.

The minimum force to be generated by the overspeed governor is double the force that ensures that the performance of the safety gears is synchronised.



The Standard demands that the installation incorporate an AC-15 or DC-13 safety contact as defined in EN 60947-5-1.

4 INSPECTIONS AND MAINTENANCE

4.1 CHECKING THE SAFETY GEARS

For the safety gears to function correctly, their proper assembly and adjustment must be verified as well as the sturdiness of the unit's connection to the car and the guide rails, as is stated in the standard EN 81:20 and EN 81:50.

It is recommended to follow the standard's provisions for inspections and tests, both for commissioning and regular testing.

The safety gear model's behaviour curves may be requested from Dynatech based on its (P+Q) and the installation's rated load when tested dynamically with suspensions included.

The proper synchronisation of the safety gears may be checked by verifying that the roller's track is marked on both guide rails and that they have a similar length, with the difference between the two sections not being more than 4 cm.

The requirements for regular tests should not be greater than those for commissioning. It is therefore recommended to always use the same load (P/Q) and speed conditions. For better control, the maintenance worker should have a safety gear operation record, where he or she records the serial number and number of operations. A visual inspection is sufficient to check that the installation has not been damaged, see section 4.3.1.

It is not necessary to work on the safety gears due to their regular tests, as long as their braking distance does not exceed double the distance recorded from the first commissioning test.

After operating the safety gear in free fall, it is recommended to contact Dynatech, or your nearest supplier, directly, who will indicate how to proceed.

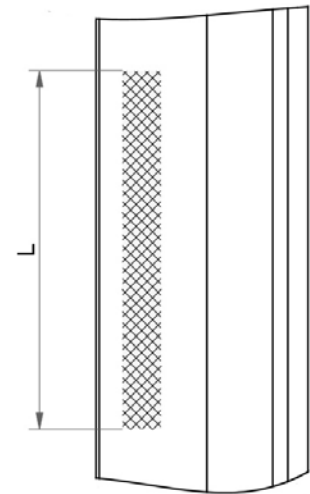

Figure 16: Braking track on guide rail

4.2 PRECAUTIONS

It is recommended to keep in mind the following items:

- The factory protective covering should be removed from the guide rails. In addition, it should be checked that there are no other objects, such as screws, brackets, etc. that may interfere with the safety gear or its driving bar.
- It should be visually checked that the safety gears are in working order, that they are not dirty or greasy inside.
- After any inspection or test where the safety gears were tripped, it should be checked that the safety gears have not been damaged.
- It is recommended to perform the tests near the car door to unload the car in order to facilitate unjamming the safety gears.
- The authorised personnel should always take the necessary precautions when tripping any of the previously installed safety gears.

4.3 MAINTENANCE

Both for maintenance and inspection, the following maintenance operations should be performed after tripping the safety gears.

4.3.1 LIST OF MAINTENANCE OPERATIONS

Safety gears:

- Check that there is no interference between the shoe and the guide rail, nor between the rollers and the guide rail.
- Check the brackets and the clearance between the safety gears and the frame, readjust it if necessary.

- Clean any remaining grease, shavings or dust inside the safety gear's housing.
- Check that there is no external element inside the safety gear's housing.
- Check that the rollers spin freely and are not damaged or worn.
- Check that the connection between the rollers and the driving bar has not been damaged and spins freely without being blocked.
- Visually check that the safety gears are not damaged in general.
- Check that the driving bar is in good condition and that the safety gears are correctly synchronised.
- Check that the car's floor does not have more than a 5% slope in comparison with its normal position.
- Check that the governor's attachment moves correctly and is in good condition.
- Check that the safety electrical contact has been correctly assembled and is functioning properly.

Guide rails:

- Clean and remove any type of dirt or dust from the guide rails.
- Eliminate the marks or burrs caused by tripping the safety gears.



The list of provisions that Dynatech establishes for the maintenance of its installed equipment is added to the Annexes.

4.3.2 CORROSION

All DYNATECH safety gears have anti-corrosion protection. However, it should be regularly checked that the safety gear's mobile elements are in perfect working condition; a jamming test will not be required, just a simple verification that all the parts are moving freely, as well as a visual inspection of the general condition of the surfaces.

These verifications should be done more regularly, as the maintenance worker considers necessary, when the installation is in an especially corrosive environment.

4.4 STORAGE AND SERVICE LIFE

The safety gear should be stored in a cool, dry place. It should be protected from excessive lighting. It should never be exposed to severe weather conditions.

Storage temperature: 5 - 40°C

Storage humidity: 15 - 85% without condensation.

The safety gears' packaging should be clean and dry, so that they can be clearly identified.

It is not permitted to place constant or unbalanced loads on a package, which may cause the package to be bent, or to allow products to be stacked one on top of the other. When stacking products or packages, the storage height should take into account their load and stability.

If the criteria established for proper maintenance are observed, the safety gears may have the same service life as the rest of the installation's fixed elements provided that their proper functioning is ensured and controlled. The element's service life is not affected by grease, dust or dirt due to the shaft's condition or to environmental conditions differing from those stated in this manual.

5 UCM

5.1 UCM SYSTEM'S PRELIMINARY DESIGN

According to EN 81:20 and EN 81:50, lifts should be equipped with means for stopping uncontrolled car movement (UCM). These means should detect UCM and stop the car. This stop must occur at a maximum distance below 1 m (among other requirements).

The safety gears may be used as a braking device for stopping the uncontrolled movement.

The values for the safety gear's braking distance may be calculated beforehand, but several installation parameters must be taken into account. The more information that is known about the physical elements that make up the system, the closer the theoretical value will be to the actual value.

These are theoretical values and may only be used in the system's preliminary design. The installation's compliance with the standard requirements is pending.

5.2 SAFETY GEAR BRAKING DISTANCE CALCULATION

The detailed calculations can be found in the manual: DYN 62.04 – UCM. Braking distance.

6 GENERAL DRAWING

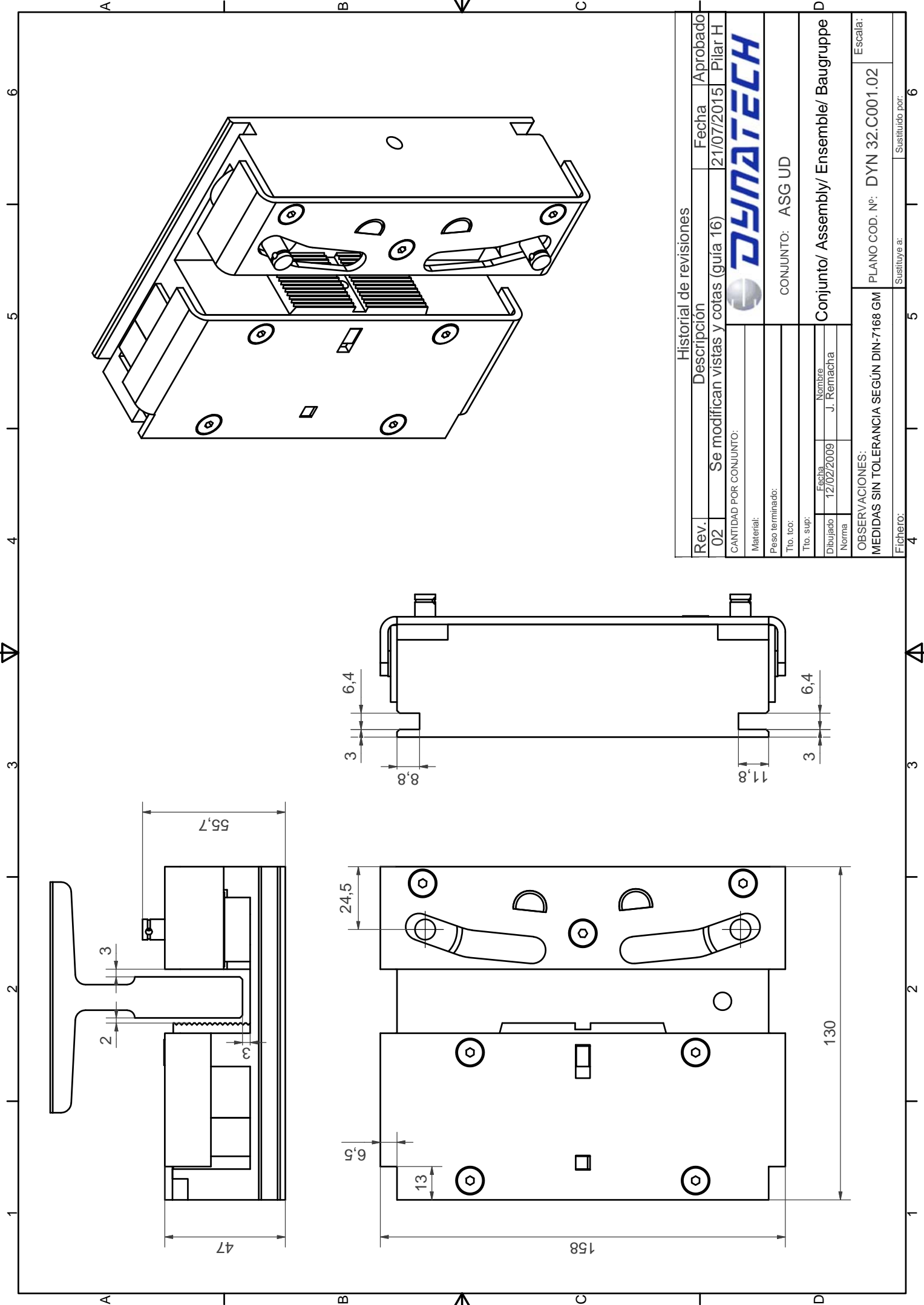

Historial de revisiones			
Rev.	Descripción	Fecha	Aprobado
02	Se modifican vistas y cotas (guía 16)	21/07/2015	Pilar H
CANTIDAD POR CONJUNTO:			
Material:			
Peso terminado:			
Tto. tco:			
Tto. sup:			
Dibujado		Fecha	Nombre
Norma		12/02/2009	J. Remacha
CONJUNTO: ASG UD			
Conjunto/ Assembly/ Ensemble/ Baugruppe			
OBSERVACIONES:		Escala:	
MEDIDAS SIN TOLERANCIA SEGÚN DIN-7168 GM		PLANO COD. N°: DYN 32.C001.02	
Fichero:		Sustituye a:	



PLANO COD. N°: DYN 32.C001.02

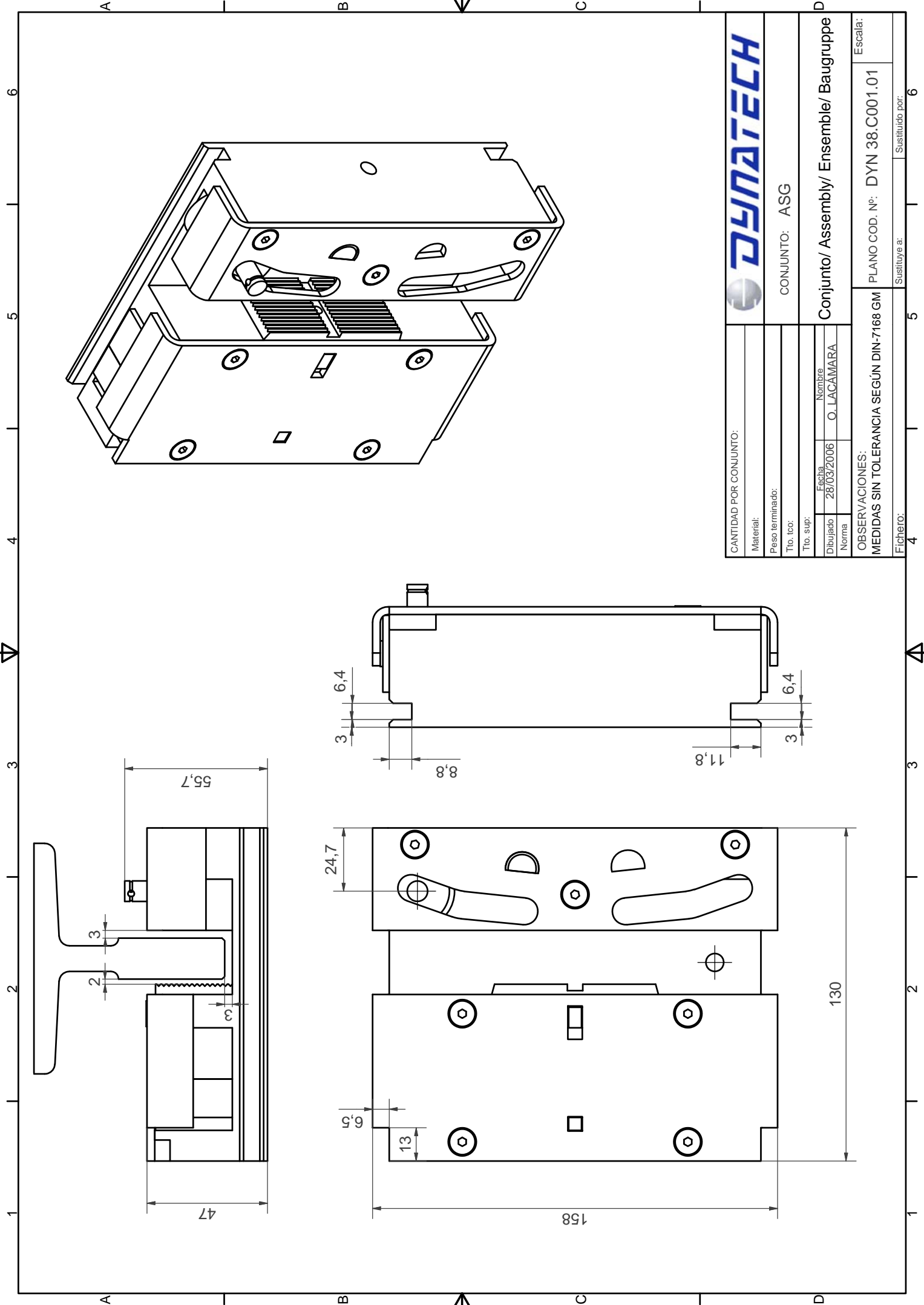

CONJUNTO: ASG

Conjunto/ Assembly/ Ensemble/ Baugruppe

Escala: PLANO COD. N°: DYN 38.C001.01

OBSERVACIONES: MEDIDAS SIN TOLERANCIA SEGÚN DIN-7168 GM

CANTIDAD POR CONJUNTO:

Material:

Peso terminado:

Tto. tco:

Tto. sup:

Dibujado: 28/03/2006

Fecha: 28/03/2006

Nombre: O. LACAMARA

Norma:

Fichero: 4

Sustituye a: 5

6

7 ANNEXES

DATE 15/10/2020
REV 0



Maintenance company		Date:
Model / Serial No.		
Reference of installation		

1. GENERAL PROVISIONS APPLICABLE TO DYNATECH SAFETY GEAR

1	PUTTING INTO SERVICE	FREQUENCY	OK	NO OK	DYNATECH INSTRUCTIONS	OBSERVATIONS
1.1	Check the proper assembly of the car safety gear	First time before putting into service	<input type="checkbox"/>	<input type="checkbox"/>		6.3.4 of EN 81:20
1.1.1	Visual check of general conditions ⁽¹⁾					
1.1.2	Check of the guide rail state				4.2	
1.1.3	Length of marks on the guide rail				4.1	
1.2	Check the proper assembly of the counterweight safety gear	First time before putting into service	<input type="checkbox"/>	<input type="checkbox"/>		6.3.5 of EN 81:20
1.2.1	Visual check of general conditions ⁽¹⁾					
1.2.2	Check of the guide rail state				4.2	
1.2.3	Length of marks on the guide rail				4.1	
(1)	Check for wear or damage in the safety gear					

2	MAINTENANCE	FREQUENCY	OK	NO OK	DYNATECH INSTRUCTIONS	OBSERVATIONS
2.1	Visual inspection and visual check	6 month	<input type="checkbox"/>	<input type="checkbox"/>	4.2	
2.2	Clean, absence of strange elements	6 month			4.2	
2.3	Controlled engagement of car	12 months	<input type="checkbox"/>	<input type="checkbox"/>	4.2	6.3.4 of EN 81:20
2.4	Visual inspections of wears	12 months			4.1	

3	MAINTENANCE CHECKLIST	OK	NO OK	DYNATECH INSTRUCTIONS	OBSERVATIONS
3.1	Check that there is no interference between shoe and guide rail.	<input type="checkbox"/>	<input type="checkbox"/>	4.3.1	adjust only if required
3.2	Check that there is no interference between rollers and guide rail	<input type="checkbox"/>	<input type="checkbox"/>	4.3.1	adjust only if required
3.3	Check the fixings and clearance between safety gear and frame	<input type="checkbox"/>	<input type="checkbox"/>	4.3.1	adjust only if required
3.4	Clean grease, chips or dust inside safety gear.	<input type="checkbox"/>	<input type="checkbox"/>	4.3.1	
3.5	Check rollers movement	<input type="checkbox"/>	<input type="checkbox"/>	4.3.1	
3.6	Visual check governor linkage	<input type="checkbox"/>	<input type="checkbox"/>	4.3.1	
3.7	Visual check for damage and defects	<input type="checkbox"/>	<input type="checkbox"/>	4.3.1	
3.8	Check driving bar state	<input type="checkbox"/>	<input type="checkbox"/>	4.3.1	
3.9	Check car inclination	<input type="checkbox"/>	<input type="checkbox"/>	4.3.1	
3.10	Check safety switch	<input type="checkbox"/>	<input type="checkbox"/>	4.3.1	
3.11	Clean guide rail	<input type="checkbox"/>	<input type="checkbox"/>	4.3.1	
3.12	Remove marks and chips from the guide rail	<input type="checkbox"/>	<input type="checkbox"/>	4.3.1	
3.13	Apply lubricant on the guide rail	<input type="checkbox"/>	<input type="checkbox"/>	4.3.1	only if required
3.14	Length of marks on the guide rail	<input type="checkbox"/>	<input type="checkbox"/>	4.1	have a register list
3.15	Begining of marks on the guide rail	<input type="checkbox"/>	<input type="checkbox"/>	4.1	
3.16	Visual check for wear	<input type="checkbox"/>	<input type="checkbox"/>		