



**DYNATECH**  
**DYNAMICS AND TECHNOLOGY, S.L.**

**LIMITADOR DE VELOCIDAD**  
**STAR**

**STAR**  
**OVERSPEED GOVERNOR**

**LIMITEUR DE VITESSE**  
**STAR**

**GESCHWINDIGKEITSBEGRENZER**  
**STAR**

**CERTIFICADOR CE DE TIPO / CERTIFICATS D'EXAMEN CE DE  
TYPE/ EC TYPE-EXAMINATION CERTIFICATE/ EG-BAUMUSTER-  
ZERTIFIKAT**

**ATISAE**

**CERTIFICADO DE EXAMEN C.E. DE TIPO**  
*EC TYPE-EXAMINATION CERTIFICATE*

Según el anexo V parte A de la Directiva 95/16/CE / According annex V part A of Directive 95/16/EC

<b>Número de certificado. / Certificate number</b>	<b>ATI / LD-VA / M109A-2 / 07</b>
<b>Organismo Notificado. Notified Body</b>	<b>Asistencia Técnica Industrial S.A.E. (ATISAE)</b> Avda. de la Industria, 51 bis E 28760 Tres Cantos MADRID (ESPAÑA) Nº de identificación <b>0053</b> .
<b>Clase. Tipo. Product. Type</b>	<b>Limitador de velocidad / Overspeed governor</b>
<b>Modelo / Model</b>	<b>STAR</b>
<b>Fabricante. Manufacturer</b>	<b>DYNATECH DYNAMICS AND TECHNOLOGY, S.L.</b> Pol. Ind. Pina de Ebro. Sector C p-9 50750 Pina de Ebro ZARAGOZA (ESPAÑA).
<b>Propietario del certificado. Certificate Owner</b>	<b>DYNATECH DYNAMICS AND TECHNOLOGY, S.L.</b> Pol. Ind. Pina de Ebro. Sector C p-9 50750 Pina de Ebro ZARAGOZA (ESPAÑA).
<b>Fecha de presentación. Date of submission</b>	<b>20/02/2007</b>
<b>Fecha del examen de tipo. Date of EC type examination.</b>	<b>12/11/2007</b>
<b>Laboratorio de ensayo. Test laboratory</b>	<b>(véase en el anexo técnico sección 2.12)</b> (Please refer to technical annex section 2.12.)
<b>Informe de ensayo / Test report</b>	<b>(véase en el anexo técnico sección 2.12)</b> (Please refer to technical annex section 2.12.)
<b>Directiva CE aplicada. / EC- Directive.</b>	<b>Directiva 95/16/CE de 29 de Junio de 1995</b>
<b>Norma de referencia. / Reference standard</b>	<b>EN 81-1/2:1998</b>
<b>Informe de ATISAE. / ATISAE report</b>	<b>ED 051047 (31.01.2005)</b> <b>MD_DEU_070739 (12.11.2007)</b>
<b>Plazo de validez / Expiry date</b>	<b>Indefinido (véase en el anexo técnico sección 2.14)</b> Indefinite (Please refer to technical annex section 2.14.)
<b>Declaración:</b>	El componente de seguridad permite al ascensor sobre el que se instale satisfacer los Requisitos de Seguridad y Salud de la citada Directiva usándose dentro del alcance que queda establecido en el anexo técnico de este certificado, así como con las condiciones de instalación indicadas.
<b>Statement:</b>	The safety component allows the lift on which installed to satisfy the requirements of health and safety of Lifts Directive when used among the scope which is established in the technical annex to this certificate, as well as under the shown installation conditions.
<b>Tres Cantos, a 12 de NOVIEMBRE de 2007</b>	 José Manuel Flores González * Coordinador Técnico
<b>Este certificado consta de esta portada, un anexo técnico de 4 hojas y 1 plano / documento. Su reproducción carece de validez si no se realiza totalmente</b>	
<b>This certificate consists of this main page, a technical annex with 4 pages and 1 drawing / document. It shall be reproduced with all its pages to be considered valid.</b>	

Procedimiento EC-12.04 Anexo 4 Rev 0 Septiembre 2005

Asistencia Técnica Industrial S.A.E. (ATISAE)  
Organismo Notificado Nº 0053 para la aplicación de la Directiva 95/16/CE  
Avda. de la Industria, 51 bis. E28760 Tres Cantos MADRID  
Tel: 91 806 17 30



**ANEXO TECNICO AL CERTIFICADO CE DE EXAMEN DE TIPO ATI/LD-VA/M109A-2/07**  
 TECHNICAL ANNEX TO THE EC TYPE EXAMINATION CERTIFICATE (ABOVE)

**El presente certificado amplía y sustituye al certificado:**  
 This certificate enhances and supersedes the previous.

**ATI / LD-VA / M109A-1 / 02**

**El alcance de la ampliación se encuentra detallado en la nota 2.1.**  
 The scope of the extension is explained in the section remarks (remark 2.1.)

**1. Campo de aplicación:**  
 Scope.

**1.1. Descripción:**  
 Brief description.

**El limitador modelo STAR, no es totalmente conforme con la norma armonizada EN 81-1:1998.**  
 "STAR" overspeed governor does not follow completely harmonised Standard EN 81-1:1998.

**El limitador STAR se concibe para ser incorporado en la propia cabina del ascensor, viajando con la misma a lo largo de todo el recorrido. Para lograr su funcionamiento correcto, se emplea un cable tensado en configuración "abierto" como muestra la figura.**

The overspeed governor "STAR" is conceived to be assembled in the car itself and travelling with it along the hoistway. In order to achieve a suitable working of the system, it is used a stressed wire rope in "open circuit" layout, as shown in the enclosed sketch.

**El tensado se puede producir por medio de sendos muelles de compresión ubicados en los extremos superior e inferior del hueco (SENSOR DOBLE FIJO) o mediante la tensión proporcionada por una masa situada en la parte inferior del recorrido (SENSOR CON MASA).**

The wire rope is stressed via both compressed springs located in the upper and lower parts of the hoistway. (Double spring tensioning device). It can also be stressed via tensioning weight located in the lower part of the hoistway (Tensioning weight).

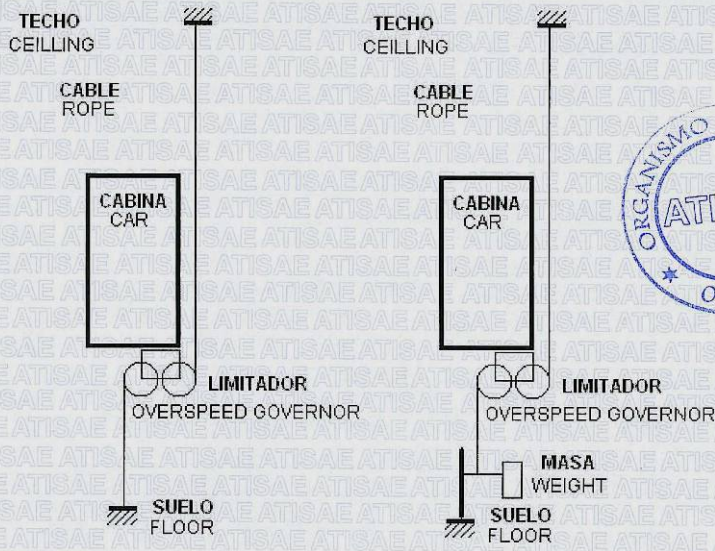



**El accionamiento del dispositivo de frenado de cabina se lleva a cabo mediante elementos rígidos unidos a la pieza denominada ESTRELLA que gira al producirse el enclavamiento.**

The tripping of the governor makes the piece called "STAR" performs a small spin and then a rigid rod or similar makes the car braking device to grip the guide rail.

**1.2. Velocidad de disparo:** **0.35 ÷ 2,72 m/s**  
Permissible tripping speed.

**1.3. Velocidad nominal:** **≤2,3 m/s**  
Permissible rated speed.

**1.4. Diámetro primitivo de la polea del limitador:** **187.3 mm**  
Pitch diameter of the governor pulley

**1.5. Cable:**  
Driving rope:

**1.5.1. Diámetro:** **6.0 mm**  
Diameter.

**1.5.2. Composición:** **6 x 19+1**  
Art.

**1.6. Mínima fuerza tensora (ver nota 2.10):**  
Minimum tensioning force. (please refer to remark 2.10)

**TENSOR DOBLE FIJO** **450 N**  
Double spring tensioning device

**TENSOR CON MASA** **490 N**  
Tensioning weight

**1.7. Fuerza transmitida a los medios de frenado con mínima fuerza tensora en todas las configuraciones:** **300 N**  
Tensile force at minimum tensioning force in every layout.

**2. Notas.**  
Remarks.

**2.1. La ampliación del alcance establecido por este certificado consiste en los siguientes ítems:**  
The scope extension is summarised in the following items:

- a) aplicación de uso unidireccional (actuación sobre paracaídas solo en sentido descendente);  
sub-model for ONLY DOWN tripping.
- b) posibilidad de uso de tensado de cable mediante masa tensora;  
optional tensioning of the wire rope by tensioning weight.
- c) ampliación a velocidades de disparo más bajas (modelo LS) para actuación SOLO BAJADA;  
extension to lower permissible tripping speeds (sub model LS) ONLY DOWN tripping.
- d) posibilidad de usar polea de desvío fabricada en poliamida.  
optional deviation pulley made of polyamide.
- e) reducción del valor de pretensado del cable en el modelo con doble tensor fijo.  
diminish the minimum tensioning force of the rope in sub-model with double spring.

**2.2. Sobre el dispositivo del limitador de velocidad debe colocarse una placa con los datos indicados a continuación:**

It shall be placed an identifiable plate on the overspeed governor with the following items.

Nombre del fabricante Manufacturer's name	Signo del examen de tipo y sus referencias CE type-examination mark and its references
--	---

Velocidad de disparo mecánico para la cual ha sido ajustado The actual tripping speed for which it has been adjusted
---

También se indicará si el limitador es de actuación unidireccional o bidireccional.  
It shall also be shown whether the governor is the type UP and DOWN or ONLY DOWN.



**Anexo técnico al certificado AT/LD-VA/M109A-2/07**  
Technical annex to the certificate

**Página 2 de 4**  
Page



- 2.3. El conjunto limitador puede ser ubicado tanto en la parte superior como inferior de cabina. Cuando se sitúe en la parte superior, accesible al personal de mantenimiento, se proveerán las protecciones adecuadas contra daños corporales. Dichas protecciones no forman parte de esta certificación.**  
The governor assembly may be located in the upper or lower side of the car. When located in the upper side and being accessible to maintenance personnel, adequate protections against bodily injuries shall be provided. Such protections are not part of this certification.
- 2.4. El limitador dispondrá de un dispositivo de disparo auxiliar con mando a distancia con el objeto de poder llevar a cabo la prueba del paracaídas.**  
The governor must have an auxiliary tripping device with cableless remote control in order to carry out the safety gear test.
- 2.5. El contacto eléctrico de seguridad del limitador es de rearme automático. También se disponen contactos contra aflojamiento de cable en ambos sub-modelos**  
The safety electric contact of the overspeed governor is reset automatically. There are also safety switches against the breakage or leakage of the rope.
- 2.6. El método de accionamiento del dispositivo de frenado, no es evaluado en esta certificación. La resistencia adecuada de los elementos de interconexión limitador-paracaídas, deben ser asegurados por el instalador para los requerimientos del dispositivo de frenado utilizado conjuntamente con el limitador y los mencionados elementos de conexión entre ambos.**  
The means transmitting the force to the car braking devices are not assessed in this certification. The installer must assure an adequate strength of the connection elements between the governor and the safety gear, according to the mechanical requirements of such elements.
- 2.7. En la variante TENSOR DOBLE FIJO, la fijación del cable del limitador estará protegida contra golpes involuntarios. El instalador deberá asegurar en la fijación en el foso, la correcta protección contra la corrosión de las partes metálicas de los elementos presentes del sistema de fijación, en previsión de un fallo de impermeabilización del foso.**  
The attachments of the rope to the well floor in sub-model with double spring shall be protected against unintentional hit. The installer must assure in the pit attachment, suitable corrode protection of metallic elements in this attachment due to a foreseeable water leak in the pit.
- 2.8. Deben respetarse los límites de pretensado indicados en la sección 1.6. El cable en cada ramal saldrá de la respectiva polea alineada con su ranura. Se evitará que exista un ángulo de salida del cable respecto de las ranuras superior a 5° en cualquier posición de la cabina.**  
The installer shall respect the tensioning limits shown in section 1.6. The rope shall be aligned with the groove of the pulleys. It must be avoided an angle between the rope and the groove of more than 5° at any position of the car.
- 2.9. Los modelos de actuación unidireccional no pueden usarse como sensor de velocidad para la actuación de dispositivos de protección contra sobrevelocidad en subida. Cuando se usen este tipo de limitadores el paracaídas también será de actuación unidireccional solo en bajada.**  
ONLY DOWN sub-model can not be used as speed monitoring devices for ascending car overspeed protection means. When using these kind of governors the safety gears shall be also ONLY DOWN.
- 2.10. El sistema tensor debe comprobarse para alcanzar el valor mínimo de tensión según las indicaciones del fabricante.**  
The tensioning system shall be tested in order to check that the minimum tensioning value is reached according to the manufacturer documentation.
- 2.11. Con polea de desvío de poliamida, la temperatura normal del hueco no superará los 50° centígrados. Si se prevé que se supere esta temperatura, la polea de poliamida debe ser sometida a inspección periódica de mantenimiento con objeto de vigilar su estado.**  
When using deviation pulley made of polyamide, the usual temperature of the shaft shall not be over 50 centigrade degrees. When it is foreseeable the temperature reaches this temperature, polyamide deviation pulley shall be periodically inspected in order to control possible deformations.
- 2.12. Laboratorios de ensayo.**  
Test laboratories.

Laboratorio / Laboratory

Ensayo / Test

Lab. de ensayo de materiales (LEM)

2000-014/1 (.10.2000)

Escuela Técnica Superior de Ingenieros Industriales

2001-013 (.10.2001)

Universidad Politécnica de Madrid

C/ José Gutiérrez Abascal, 2.

28006 MADRID (ESPAÑA)

Lab. de ensayo de componentes de ascensores (LECA)

2007-004 (18.06.2007)

Escuela Técnica Superior de Ingenieros Industriales

Universidad Politécnica de Madrid

C/ José Gutiérrez Abascal, 2.

28006 MADRID (ESPAÑA)





# ATISAE

**2.13. Se adjunta a la presente certificación los siguientes documentos:**

The following documents are enclosed to this certificate.

DESIGNACIÓN	FECHA	LEYENDA
Number	Date	Title
DYN 09.000.01	13.11.01	CONJUNTO LIMITADOR STAR

Este plano se adjunta con objeto de proporcionar identificación e información sobre el diseño básico del componente de seguridad.

This drawing is enclosed in order to provide identification and information about the basic design of the safety component.

**2.14. Este certificado perderá su validez debido a cambios de diseño, cambios en la legislación o en la normativa aplicable. El fabricante deberá poner en conocimiento de este Organismo Notificado cualquier cambio previsto de diseño.**

This certificate would loose its validity because of design modifications, changes in the applicable law or standards. The manufacturer must communicate to this Notified Body any foreseeable change in the design.

- o -



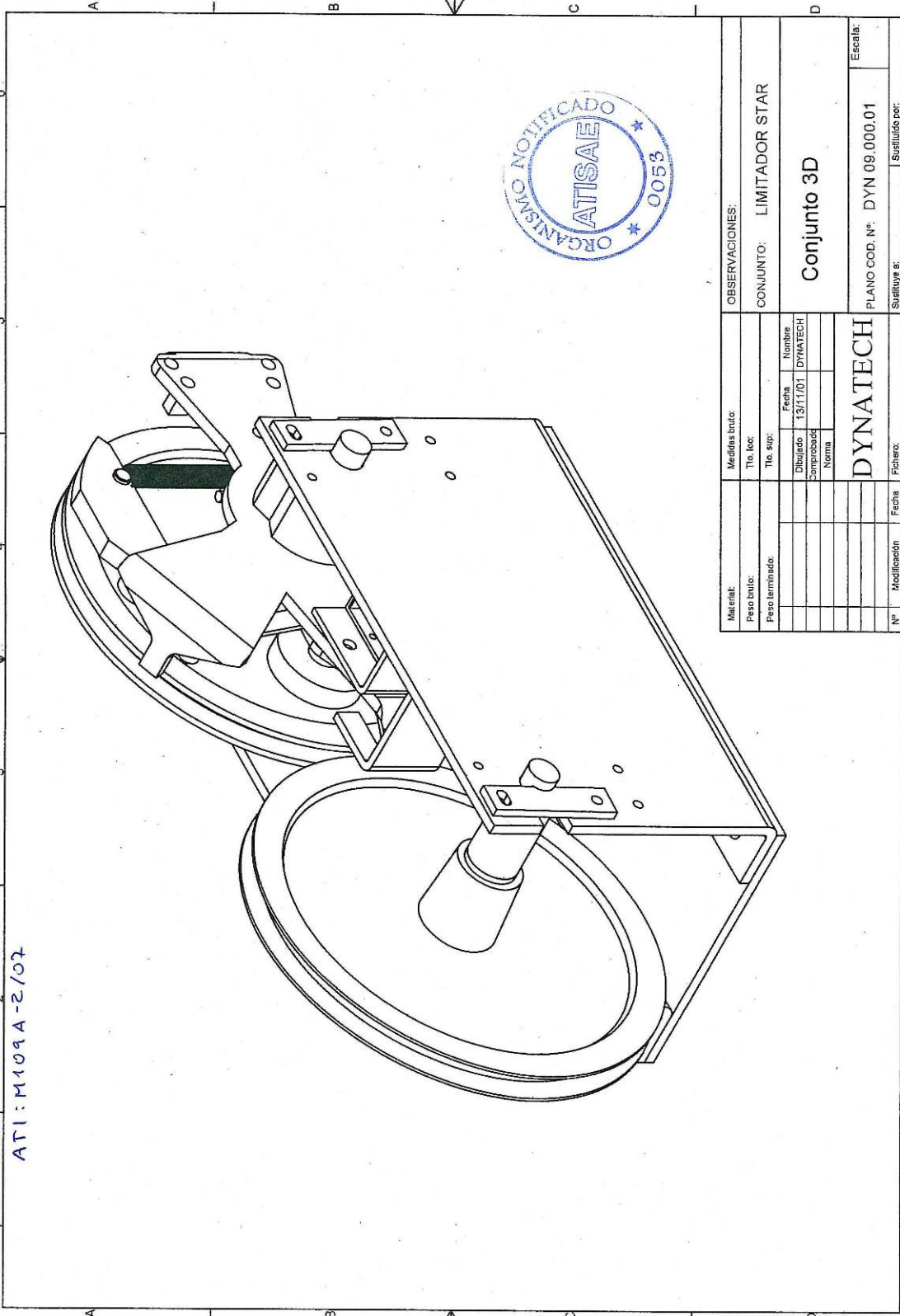

ATI:M109A-2/07



Materia:		Medidas bruto:		OBSERVACIONES:	
Peso bruto:		Tto. lco:		CONJUNTO: LIMITADOR STAR	
Peso terminado:		Tto. sup:		Conjunto 3D	
		Dibujado:	Fecha:	PLANO COD. N°: DYN 09.000.01	
		Comprobado:	13/11/01	Escala:	
		Norma:	DYNATECH	Suftiyye a:	
				Suftiyye por:	
N°:	Modificación:	Fecha:	Fichero:		

# DYNATECH DYNAMICS AND TECHNOLOGY, S.L.

## STAR OVERSPEED GOVERNOR

### CONTENTS

1	INTRODUCTION.....	37
2	MAIN COMPONENTS.....	37
3	WORKING PRINCIPLES.....	38
3.1	<i>ROPE TENSING SYSTEM</i> .....	44
3.2	<i>REMOTE TRIPPING SYSTEM</i> .....	49
3.3	<i>OVERSPEED CONTACT</i> .....	50
3.4	<i>PARKING SYSTEM (OPTIONAL DEVICE)</i> .....	51
3.5	<i>STAR LS OVERSPEED GOVERNOR</i> .....	52
3.6	<i>CURRENT RECTIFIER</i> .....	52
4	FIXING.....	54
4.1	<i>ATTACHING THE GOVERNOR</i> .....	54
4.2	<i>ATTACHING THE TENSORS</i> .....	54
5	TECHNICAL FEATURES.....	56
6	TYPE OF ADJUSTMENT.....	57
7	INSTRUCTIONS FOR USE AND MAINTENANCE.....	58
8	INSTALLATION DRAWINGS.....	60



## **1 INTRODUCTION.**

STAR overspeed governor by DYNATECH is specially designed to be fitted into the car or sling of the lift and to move together with them. Thanks to this, the engine room governor, the guide pulley and the mass at the bottom of the well can be removed.

By using this new concept, the governor moves, whereas the rope remains fixed, anchored to the well ceiling and to the pit by means of a small-sized tensing system. The information on the set of devices integrating the Governor will be broadened later on.

## **2 MAIN COMPONENTS.**

Each governor is composed of the following main elements: two pulleys, a centrifugal system, a locking device, a casing and an element linking the governor to the car or sling.

Below, a figure representing the governor set is shown:

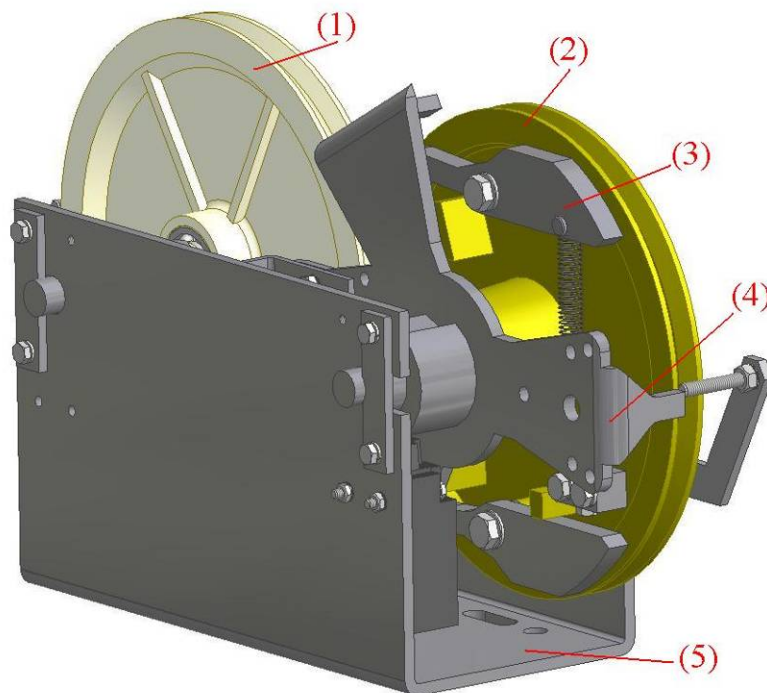

Where:

- (1) – Guide Pulley.
- (2) – Main Pulley.
- (3) – Centrifugal system.
- (4) – Locking system.
- (5) – Car or sling fixing plate.

### 3 WORKING PRINCIPLES.

The governor is of the centrifugal type, and is able to work either **upwards** or **downwards**.

As mentioned above, the designed object is fixed into the car or into the sling of the lift, and it can be placed either above or below both. The rope, anchored to the ceiling and to the pit floor, passes through the governor, along the pulley jaws. This way, when the car reaches its tripping speed, the rope-governor relative movement will lock it. This governor locking will drive the safety gear and will stop the car movement.

Working diagram is as follows:



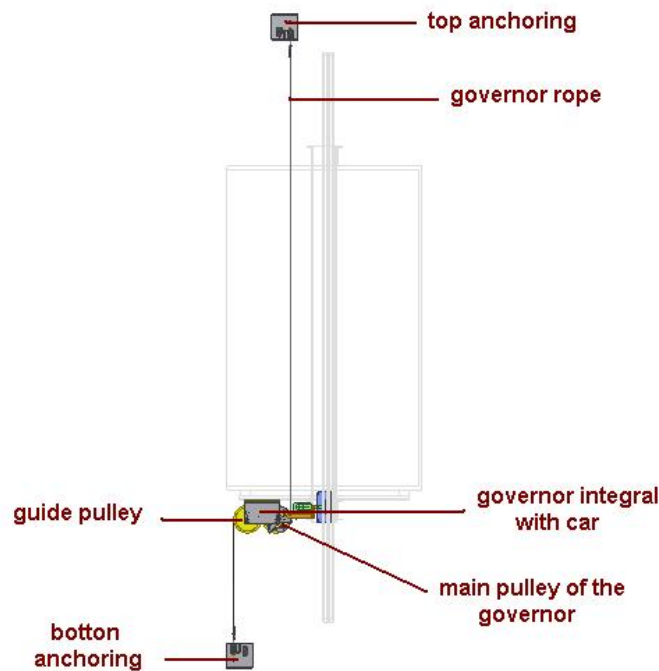

Such is the interlocking process that, when the car speed exceeds a pre-set level (governor tripping speed), the centrifugal system, together with the pulley, interlocks with the governor "locking system", which, in turn, is coupled to the driving bar by means of an auxiliary component. At this moment, the main pulley locks and the friction between the rope and the pulley is transferred to the safety gear through the auxiliary component and the driving bar. The safety gear, on wedging, will cause the car to stop.

It is important to remark that the connection between governor and safety gear is not carried out through the governor rope, but through an auxiliary mechanical system.

Below, a more detailed view of one of the possible governor positions in the lift, as well as of the above-mentioned parts, is given. In the first view, the governor placed below the car is shown.

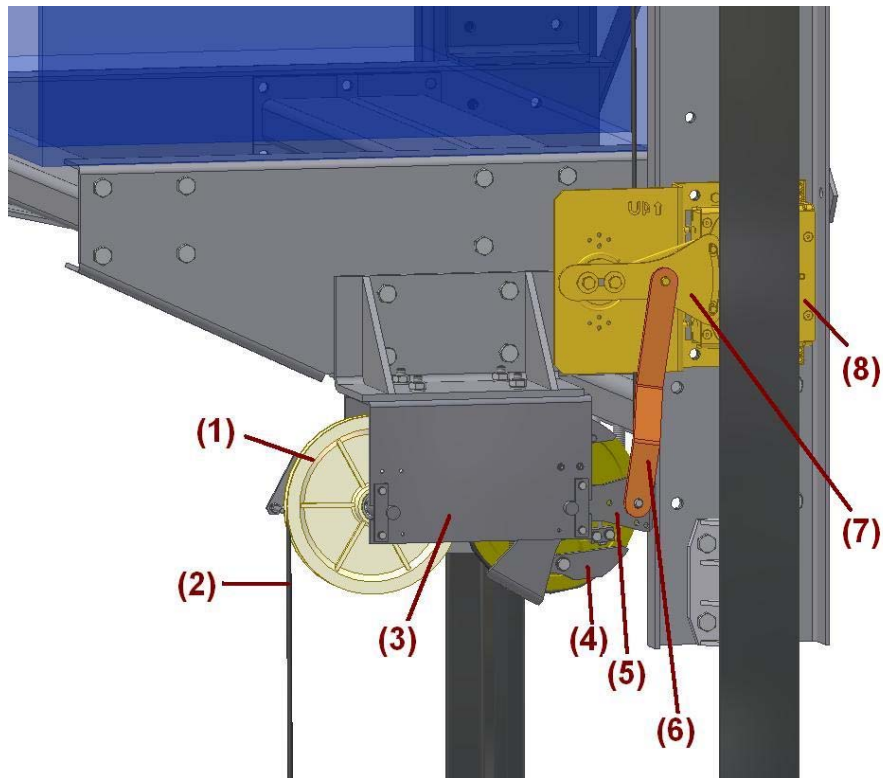

Where:

- (9) – Guide pulley.
- (10) – Rope.
- (11) – Governor.
- (12) – Centrifugal system.
- (13) – Locking device.
- (14) – Auxiliary system.
- (15) – Driving bar.
- (16) – Safety gear.

The governor placed in a lower position would be as follows:



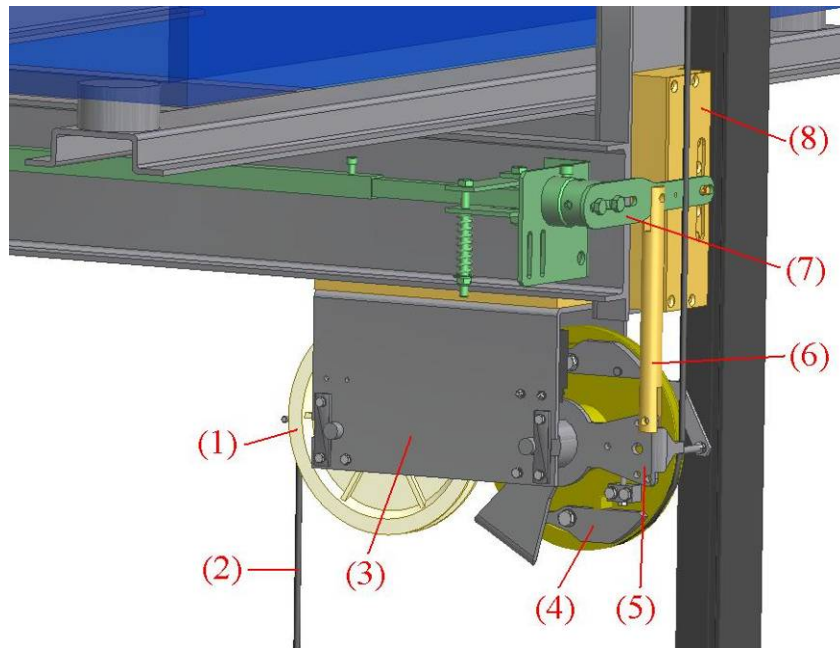

Where the numbers match those of the previous view.

If the driving bar and the safety gear are placed above the car, this would be as follows:

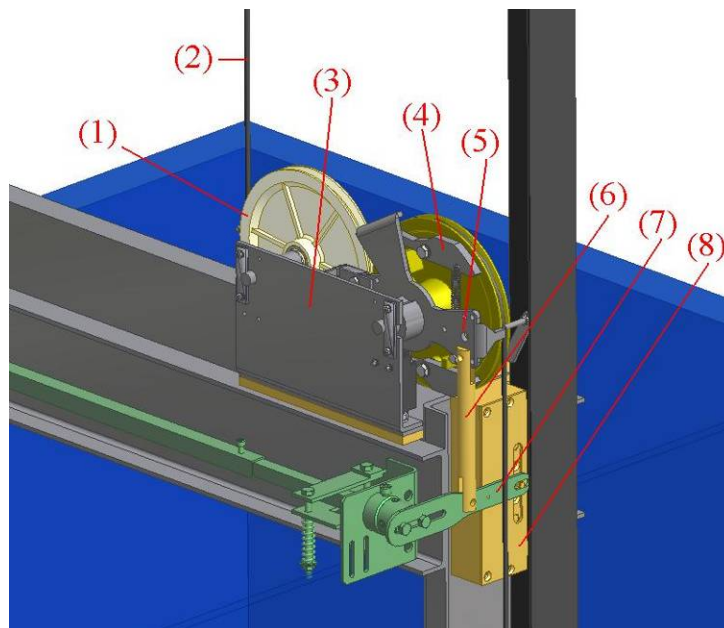

In the last example, the picture doesn't display it but the speed governor has a protecting case.

Bearing in mind that the governor position in the car depends on the customer's design, the auxiliary system coupling the governor to the driving bar must be made by the lift manufacturer.

**GOVERNOR HAND**

As mentioned above, the customer can install the limiter according to their own possibilities and convenience. For added versatility, the customer can install the limiter right or left handed. A right-handed limiter means the main pulley is also on the right side. See the figures below

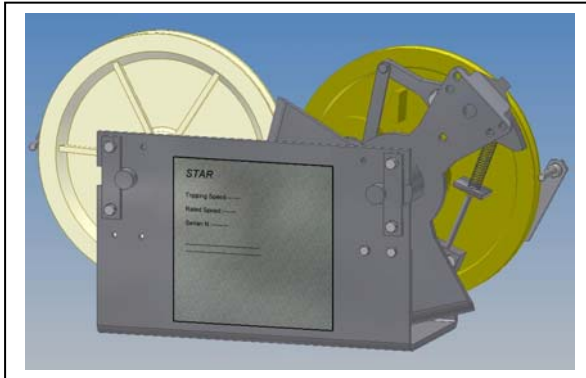

*RIGHT-HANDED STAR*

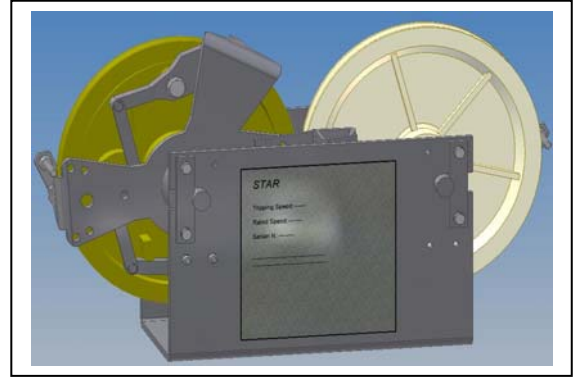

*LEFT-HANDED STAR*

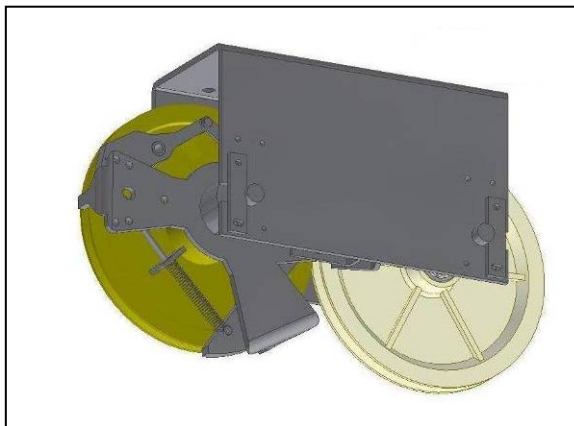

*RIGHT-HANDED STAR  
FACE DOWN*

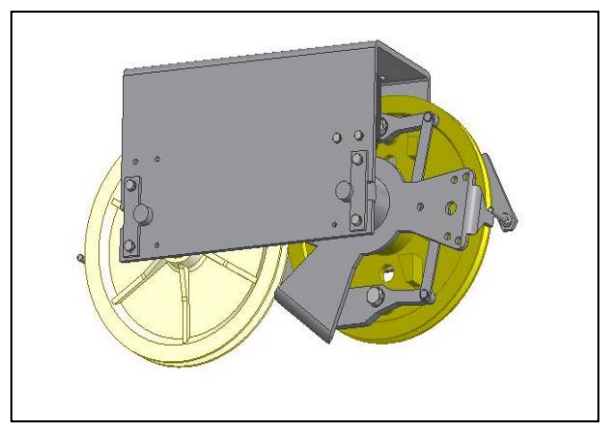

*LEFT-HANDED STAR  
FACE DOWN*

Note also that when a right-handed star is placed face down, the main pulley is on the left.



## ANCHORING THE AUXILIARY SYSTEM

Below is attached, an enlarged drawing of the five anchoring drills of said auxiliary system to the locking device.

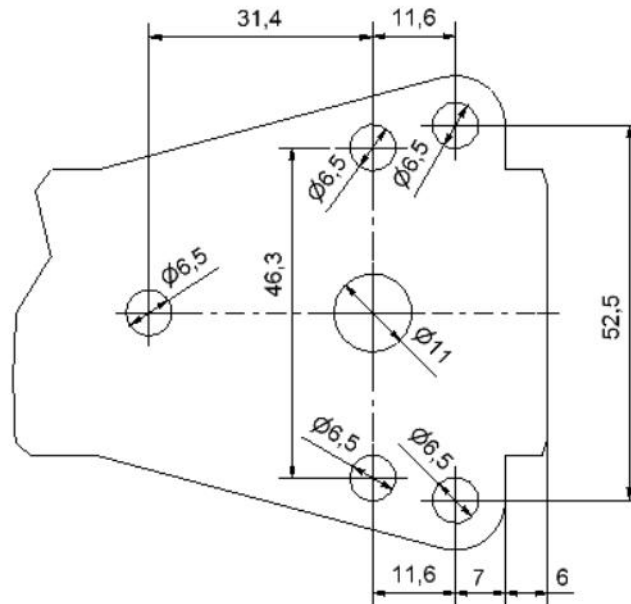

The guide pulley is used to re-divert the rope towards the tensor placed in the pit. This pulley rotates whenever there is movement of the car, even when the main pulley is locked. That is why we can assure that said pulley follows the car movement perfectly.

This is very important as it allows us to know the position of the lift at any time, by installing an Encoder on said pulley. (Dynatech offers its customers this possibility in the “Star Plus” governor).

Another important part of the Governor set is the rope tensing system. Below, the workings are briefly explained.

### 3.1 ROPE TENSING SYSTEM.

The rope is anchored to the pit and ceiling of the lift well, by means of a tensing spring system, in such a way that neither weight nor guide pulley are necessary in the pit.

The “detensing contacts” will be placed together with the anchorings. Said contacts must be connected parallel and, in turn, to the installation security series line.

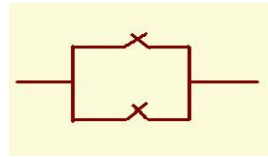

The aim of the two contacts is to detect rope breakage or detensing, as, in such a case, both springs will drive the contacts. In the case of wedging, one of the springs will loosen and the other will tighten. As a result, therefore, only one of the two contacts will open without modifying the series line.

Below, a picture of the pit tensing device is shown:

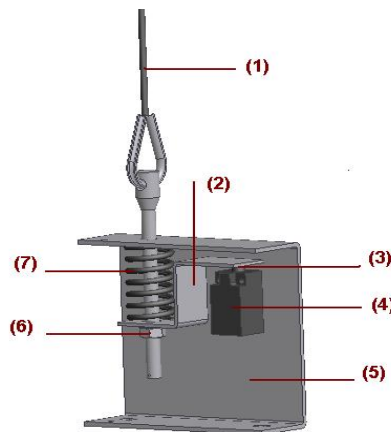

Where:

- (1) - Rope.
- (2) – Driving plate.
- (3) – Contact point
- (4) – Detensing contact.
- (5) – Bearing plate.
- (6) – Adjusting nut.
- (7) – Tensing spring.



Tensing is carried out by means of the “adjusting nut”, as this will compress the spring to the maximum position allowed by the driving plate.

The tensioning process using Star governor tensioners is indicated in detail below.

The diagram below shows how the tensioner is supplied.

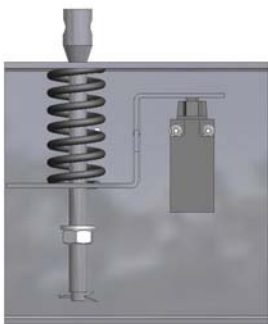

The spring is not compressed and the tensioner is supplied without any tension.

The tensioning nut **(6)** must be in its minimum position, as the tensioner’s rod **(8)** must have a larger range than the distance between the drive plate and the contact when tensioning the rope.

As can be seen in the diagram above, unthread the nut to the lower position of the rod and then insert the rope in the hole in the rod (use a thimble so as not to damage the cable). Then, pre-tension the rope with an  $F$  force.

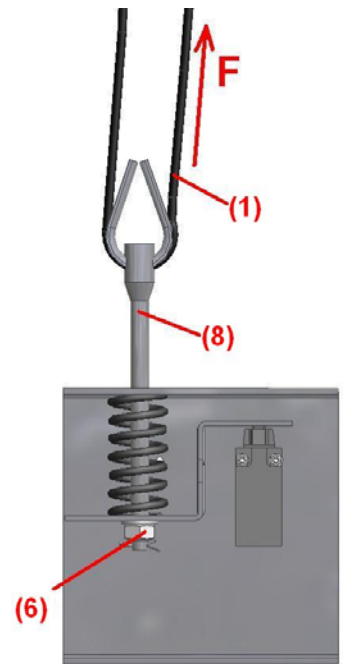

*Maximum position*

The force needed to pre-tension the rope will depend on how many metres of cable there are in the installation.

It is important to pre-tension the rope to avoid excessive loosening due to the extension of the rope, however, it is not good

for the cable to be pre-tensioned in excess, as this only reduces its life-span, as well as that of the overspeed governor.

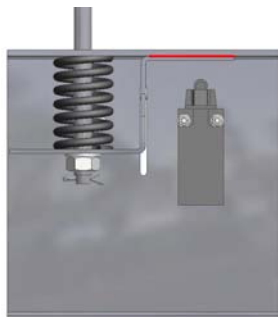

In order to know if it is being pre-tensioned in excess, we should pay close attention to the drive plate. When it touches the support, pre-tension should be reduced, as if we continue pre-tensioning, the rope will be over-tensioned without reason.

**N.B.:** The images refer to the tensioning of the lower tensioner (pit). However, before proceeding with this tensioner, the rope must have already been fitted in the upper tensioner. To do so, the nut must also be unthreaded to its minimum position. This tensioner does not have to be pretensioned, as this will be done on the lower one.



Maintaining the pre-tensioning on the rope, fit the rope ties to secure it.

The pre-tension must be removed once the rope ties have been screwed in place.

Then apply tension to the rope using the nut. Tighten the nut until the trigger plate touches the tensioner's U-support. See diagram below.

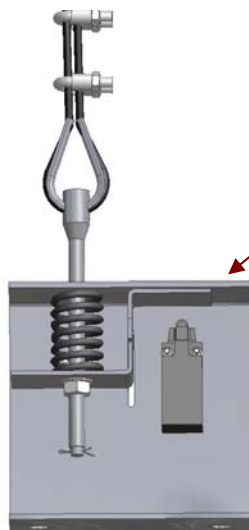

*The drive plate has to touch the support.*

Follow these steps during assembly to ensure the cable has the appropriate tension and is not continuously loosened.

This tensioning process should be carried out on the two tensioners.

As has been previously said, once pre-tensioned, the rope will then be tensioned using the tensioning nut, until the drive plate touches the U support. However, if the plate is already touching the U support due to strong pre-tensioning, it should not be tensioned with the nut more than necessary, as this would apply more tension to the cable than that required.

The "maximum position" indicated above can be seen in the diagram below:



Where (1) is the “loosening margin”

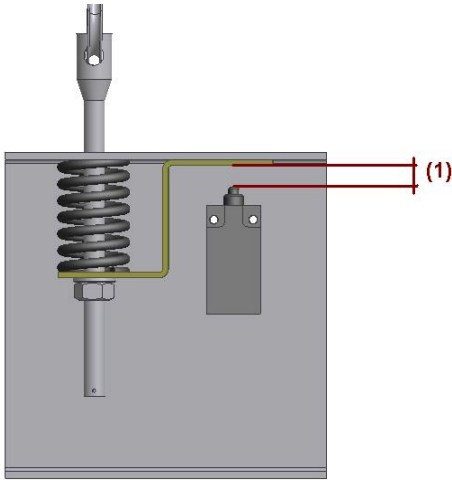

If the rope becomes loose or breaks, on recovering its natural length, the springs will allow for the plates to drive the contacts. This ensures machine stoppage.

The spring tensioning system is sensitive to the rope length so that very long cables must be re-tensioned once the cable has reached its final length. For this reason, it is important to pre-tension the cable with the nut unthreaded until the minimum position of the rod; this way, should retensioning the rope be necessary, we would have a higher retensioning margin.

**N.B.:** There are different tensioning devices for greater versatility when mounting the Overspeed governor, depending on the requirements of each installation. See website for further information.

### PRECAUTIONS WHEN INSTALLING THE ROPE

The correct installation of the governor rope is decisive for the good operation of the overspeed governor as well as for its life-span; therefore, special attention should be paid to what is explained below.

As has previously been said, it is very important to give the cable the correct tension, as over-tensioning can reduce the cable lifespan and prematurely wear out the components of the limiter.

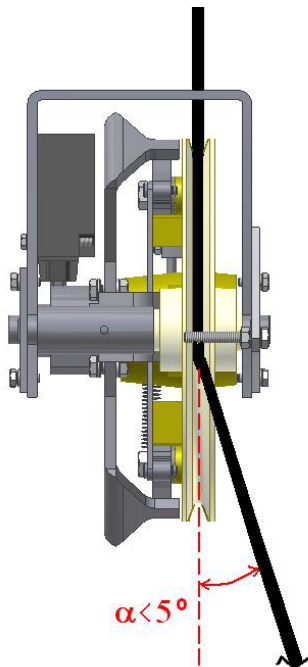

Apart from this, the rope slope is also to be taken into account, that is to say, the highest angle that the rope can form with the guide sheave.

In the diagram on the left, we can see the rope and the limiter. The angle  $\alpha$  is the angle formed by the rope and the shaft of the drive sheave, this should not be higher than  $5^\circ$ , as, otherwise, unexpected wear-out and incorrect operation of the governor may occur.

For the overspeed governors Star with guide pulley made of polyamide, the customer must take into account what is explained above, but also they will take special attention when tightening the rope too much, since otherwise deformations and noise could appear in the pulley.

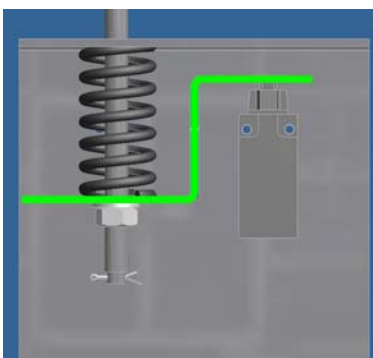

► Once the rope is tightened, if it loses tension, the drive plate of the tension device of the pit and the roof, would activate the electric switch.

This minimum tension is about 45 Kg.

With less than 45 Kg, the overspeed governor



would not work.

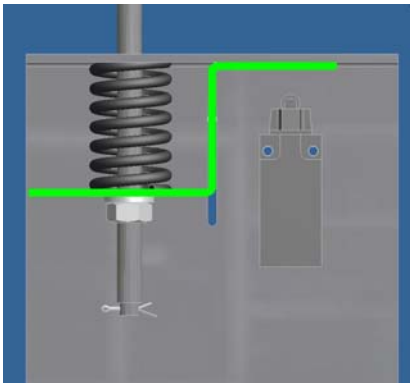

► In order to know the maximum tension in the governor, you must look at the drive plate. This plate must touch the main support. Once this tension is reached (about 85 Kg), although you can keep on tensioning physically by means of the tensioning nut, It's not recommended since this way, the governor and the rope Could not work properly.

- As an explanatory note, it's stated that the polyamide pulley can resist to 140 Kg. A greater tension than this data, Could cause deformations and noise in the pulley.

However, if there are customers that can't guarantee not to exceed this tension, they can order the governors with cast iron guide pulley. Although as mentioned before, 140 Kg is a high tension that Could cause premature wear and a malfunctioning of the device.

### **3.2 REMOTE TRIPPING SYSTEM.**

The governor has a built-in remote tripping system to check the correct interlocking of the governor and the subsequent safety gear wedging.

Basically, it consists of a remote interlocking electromagnetic system, which can be driven from the engine room. In order to help during the installation, three versions of the system are available.

- Solenoid fed by **24 V** DC (direct current). A current of **1,1 A** must be provided.
- Solenoid fed by **48 V** DC (direct current). A current of **0,75 A** must be provided.
- Solenoid fed by **190 V** DC (direct current). A current of **0,2 A** must be provided.

**Remark:** *Anyway just a few seconds are necessary to engage the system. After the activation, the current that feeds the solenoid must be switched off to avoid its overheating. In that way, a button is recommended to activate the system.*

Some images of this, as well as of its position in the set are shown in the next pictures (1).



### 3.3 OVERSPEED CONTACT.

The governor has a built-in overspeed contact. Bearing in mind that the governor will be placed in the car, said contact will have automatic rearming. In any case, the starting of the lift after interlocking must be carried out by a qualified person, but without the need for direct access to the governor.

Below, a picture of the overspeed contact position is shown, where (1) is the automatic rearming contact.

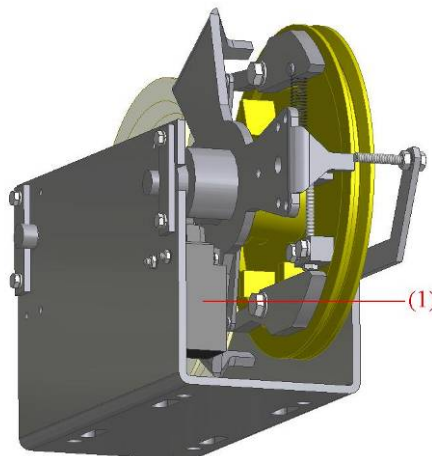

### 3.4 PARKING SYSTEM (OPTIONAL DEVICE)

The Parking system or anti-creep system is a device designed to keep the overspeed governor locked when the lift is not moving. Therefore, if an uncontrolled movement of the car occurs, the governor would operate the safety gear and the car would remain locked.

This application is interesting for maintenance work in which the person is working with the car of the lift above them.

It is important to bear in mind that, if this device receives current, the overspeed governor will be released and, when there is no current, the mechanism will lock the governor. Therefore, it is advisable to use some sort of independent supply, so that, if there was a power cut in the installation and we have to move the car manually, this supply would

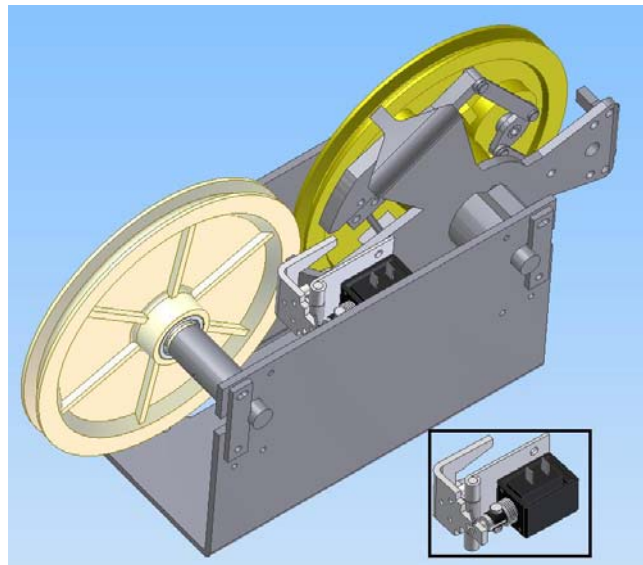

be used to release the parking system and, at the same time, unlock the governor.

As can be seen in the diagram, the system is in the same place as the remote tripping device, in fact, it would operate the other way round.

This mechanism operates as remote control, therefore, when a STAR with Parking System is fitted, a remote control will not be fitted separately.

In order for the parking system to work as a remote tripping, the installer should design an independent circuit which deactivates the parking system momentarily to lock the limiter at a specific moment. In this way, test of engagements can be carried out.



**Note:** depending on the length and cross section of the cable installed, the voltage supplied and the voltage in the parking system coil may be different, i.e. the voltage in the coil may be lower. The voltage may therefore be increased to offset this power drop in the cable.

The coils fitted in the parking system are of the 100% type and there is no risk of overheating.

A power supply of 30 V is accepted for the 24 V coil, 54 V for the 48 V coil and 195 V for the 190V coil.

### 3.5 STAR LS OVERSPEED GOVERNOR

There is a low speed STAR limiter called STAR LS.

The minimum performance speed is 0.35 m/s

This governor is DOWNWARDS ACTING ONLY and the performance speed range is:

0.35 – 0.6 m/s

**IMPORTANT NOTE:** Customers asking for a STAR LS, may know that it's unidirectional. In order to know the right way, it must pay attention to the arrow in the governor.

### 3.6 CURRENT RECTIFIER

There is the option of requesting the Star governor with a current rectifier attached. This option is related to remote tripping and the parking system.

As the coils of these 190Vdc devices are coupled to the rectifier, the customer need do no more than connect the rectifier to the 230Vac mains.

The rectifier is a device which converts alternating current to direct current, which allows the current coil to continue working.

The rectifier is enclosed in a box with an IP67, which is bolted to the governor star. As shown in the figure, a cable from the box is connected directly to the device coil (remote tripping or parking system).

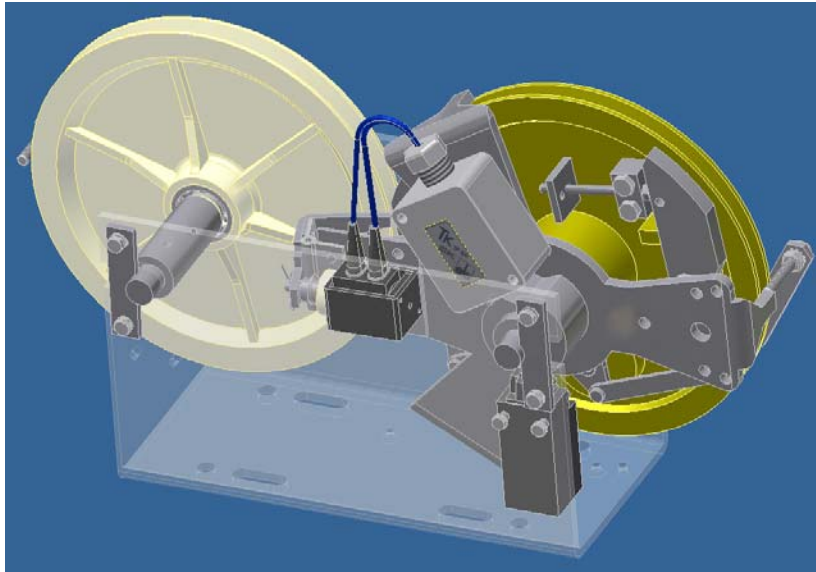

To connect the cable for the 230Vac mains, remove the screws on the box. Inside the box the bridge rectifier has 4 terminals, 2 of them go to the coil and the other 2 are for connection to the 230 V supply.

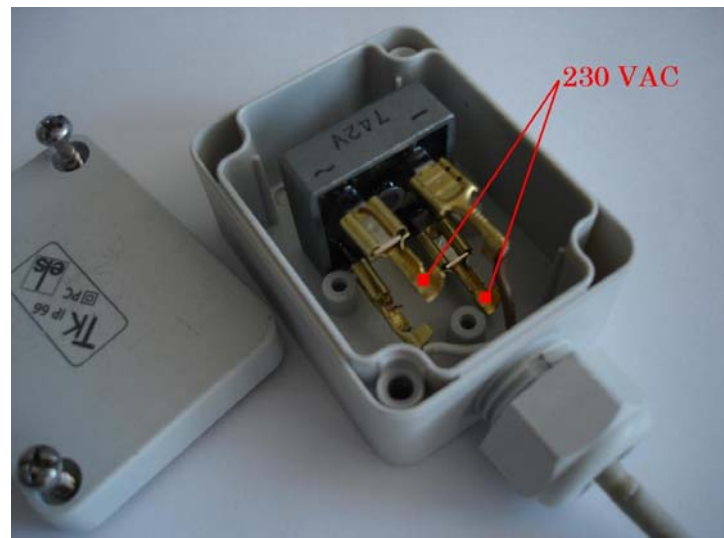

Unscrew the gland to put the wires through the hole in the box.  
Once the wires are stripped, place in the Fastons (use proper electrical tools for the assembly).

## 4 FIXING

### 4.1 ATTACHING THE GOVERNOR

The figure on the next page shows governor anchoring points to the lift sling. Marks appear in millimetres.

The governor must be anchored by means of 4 8.8-quality M10 screws. Suitable lengths are between 30 and 40 mm. Tightening torque must be 80 Nw·m. It is advisable to use Autoblock nuts in order to avoid possible screw loosening

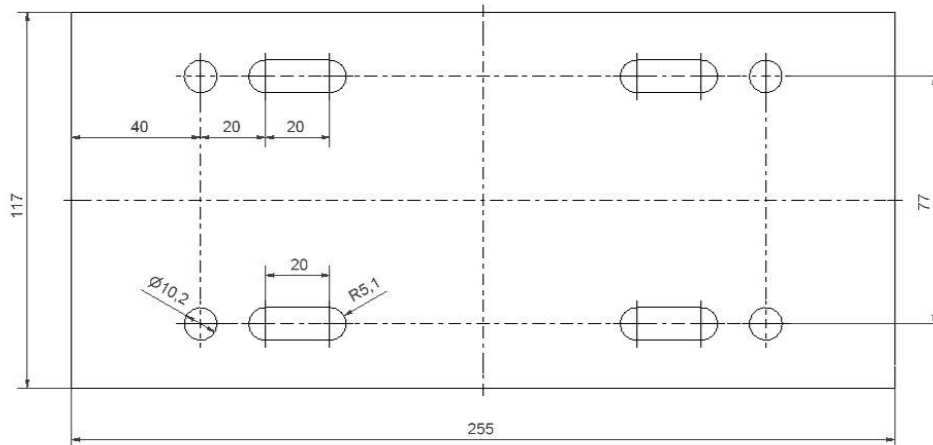

### 4.2 ATTACHING THE TENSORS

The tensors included with the Star limiter can be attached to the pit and the ceiling directly or to the guide rails (see Star tensors manual).

To attach the two tensors to the pit and to the roof, respectively, use bolts or M10 studs of 8.8 quality. The attachment to the roof and pit must be able to support 200 kg of traction.

The following diagrams show how the tensor is attached:



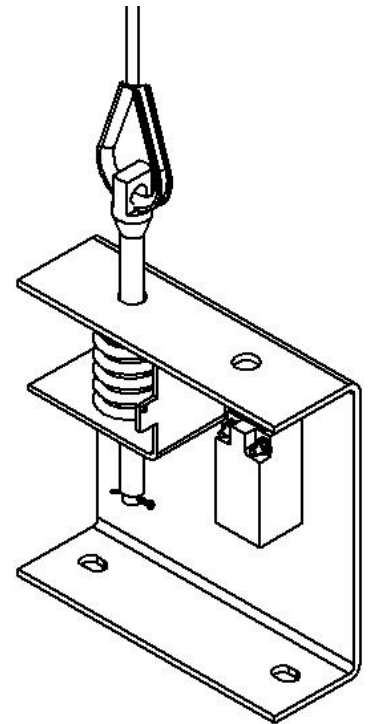
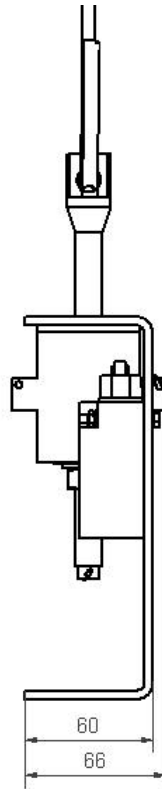
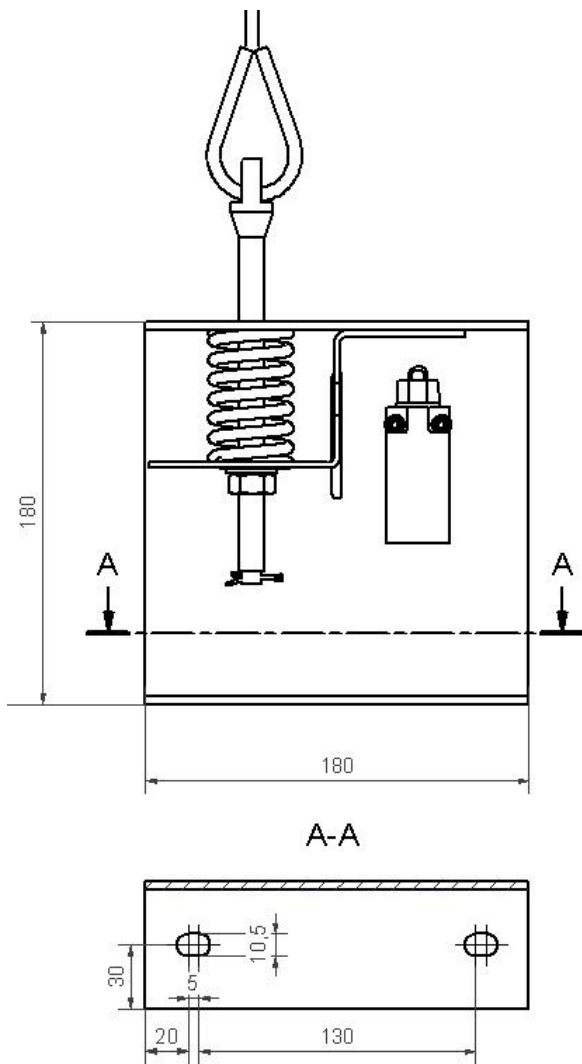

## 5 TECHNICAL FEATURES.

- **Machine:** Overspeed governor
- **Model:** STAR
- **Manufacturing company:**  
DYNATECH, DYNAMICS & TECHNOLOGY, S.L.

### Performance field:

Maximum rated speed: **2.3 m/s**

Maximum performance speed: **2.66 m/s**

Minimum rated speed: **0.1 m/s**

Minimum performance speed: **0.35 – 0.66 m/s DOWNWARDS**

*\*From 0.6 – 2.66 m/s the limiter can be DOWNWARDS and BIDIRECTIONAL*

**IMPORTANT NOTE:** Customers asking for Unidirectional model of STAR, must specify if the governor will be placed under or on the cabin.

- **Rope:**
  - Diameter: 6 mm
  - Composition: 6 x 19 + 1
- **Rope anti-fall out system**
- **Rope tension:**
  - 450 N minimum (Spring tensioner)
  - 490 N (Weight tensioner)
- **Tension produced in the connection between the driving bar and the governor:**
  - Greater than 300 N
- **Pulley diameter:** 200 mm
- **Overspeed contact.**
  - Explained in Section 3.3
- **Serial remote interlocking:**
  - Explained in Section 3.2
- **Other features:**

- Possibility of assembling an encoder to report the position of the car at all times. (**Star Plus Model**)
  - The governor has 3 engagement points, in this way the distance between two consecutive interlocking points is limited to a maximum of 200 mm.
  - STAR overspeed governors will always be assembled with first quality **bearings**.
  - Possibility of mounting an anti-creep system (Parking System) that locks the overspeed governor when there is no current.
  - Possibility of installing types of tensioners of greater versatility when mounting.
  - Option to install a rectifier for the coils
  - Can be downwards or bidirectional.
  - SKF Explorer bearings

- **Safety gears with which it may be used:**

All safety gears whose tripping speed can be reached by the overspeed governor.

Remark: For tripping speeds below 1 m/s (generally instantaneous safety gears) a specifically designed version for low speeds will be supplied (**STAR BV**). This overspeed governor has the same dimensions and technical features than the standard one.

For performance speeds between 0.35 m/s – 0.6 m/s the STAR LS limiter will be fitted and has a DOWNWARDS system.

## **6 TYPE OF ADJUSTMENT.**

Tripping speed adjusting is carried out by means of a regulating screw which tenses or detenses the centrifugal system spring. When tensing the spring, the speed required to drive the centrifugal system will be higher. In this way, tripping speed can be adjusted within the speed range.

Said adjustment is carried out in the factory by means of a computerised gauging system according to customer's specifications. Once the adjustment is



finished and checked, it is sealed so that it cannot be modified.

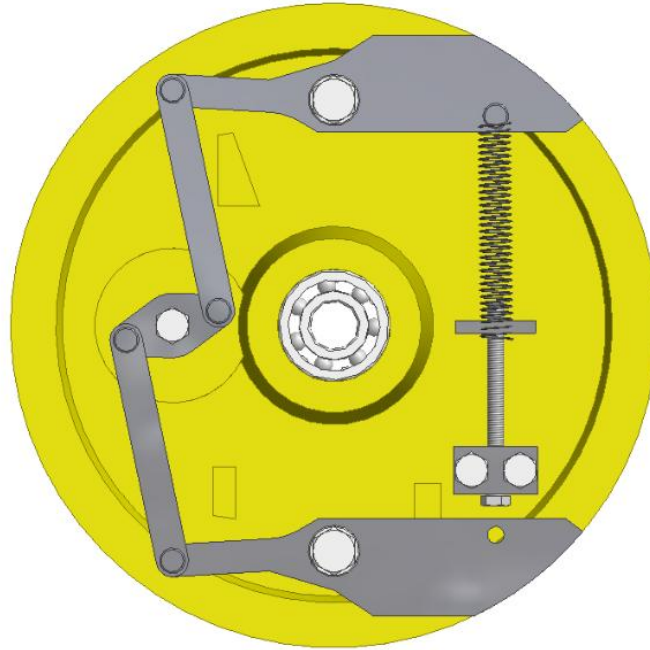

## 7 INSTRUCTIONS FOR USE AND MAINTENANCE.

Positioning of the governor on the sling can be varied: at the top, at the bottom, in a cross-sectional or horizontal position... End location will depend on frame manufacturer's criteria. However, the marks and technical information supplied for that purpose must be taken into account, so that the governor functions accordingly.

The frame manufacturer must provide for the positioning of an articulated driving system between the governor and the driving bar. Depending on the distance between them, said system must bear the compression stress produced by wedging without causing bending. For this reason, it is recommended to place the governor as close as possible to the safety gear, so that the driving system is light, simple and does not send an inappropriate torque to the governor.

Checking of the tripping speed in the installation can be carried out acting on the engine frequency changer by progressively increasing the engine speed until interlocking is obtained.

To avoid unnecessary risks that may cause incorrect governor functioning, two basic criteria must be taken into account: cleaning and monitoring for corrosion. There are moving elements in any governor that will carry out the action of interlocking. Dirt accumulation in these elements can cause malfunctioning. It is of vital importance that both the installer and the maintenance staff ensure that these elements are perfectly cleaned.

On the other hand, Dynatech governors have rustproof protection in all cases but it is important that the maintenance staff determine the possible existence of a corrosive process that may affect any mobile part of the element and stop its natural movement. This check will be carried out by visually inspecting the surface condition and by carrying out a wedging using the remote interlocking system. The frequency of these inspections is at the discretion of the maintenance staff, although they should be more frequent in the case of an especially corrosive environment.

For overspeed governors fitted with polyamide guide pulley, bear in mind the correct installation of the rope we have previously mentioned as well as the temperature that the governor may be at, carrying out regular checks in case the temperature in the well is above 50° C.

Dynatech will not be responsible for any problem or accident caused by not observing the prescriptions and recommendations described, both in these instructions and in the EEC Type-examination certificate documents.

## 8 INSTALLATION DRAWINGS.

The following drawings may be of help when adapting and installing the STAR overspeed governor to the sling.

Front view:

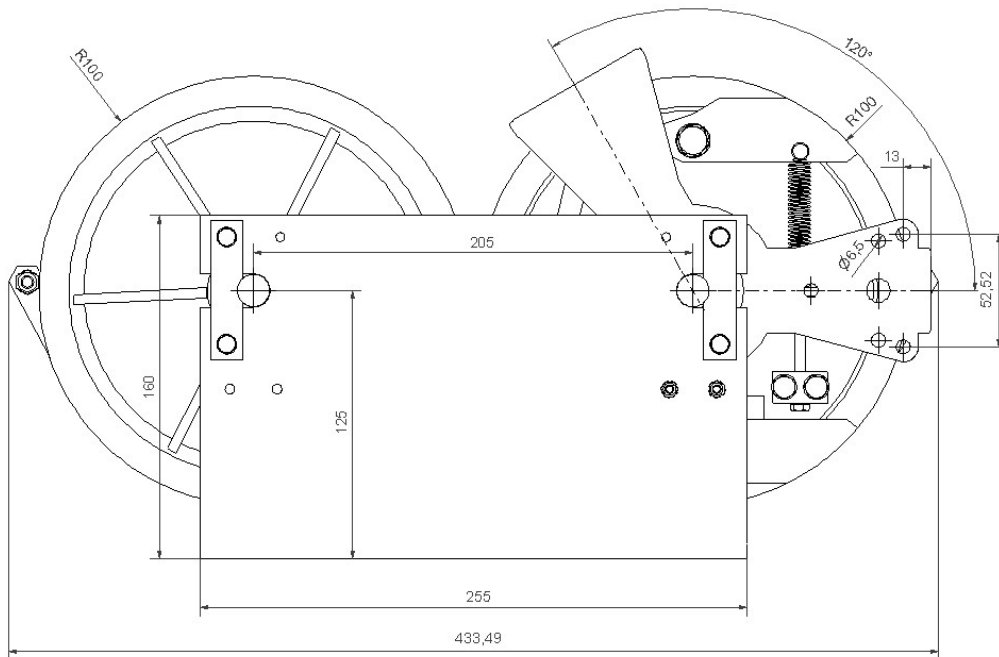

Bottom view:

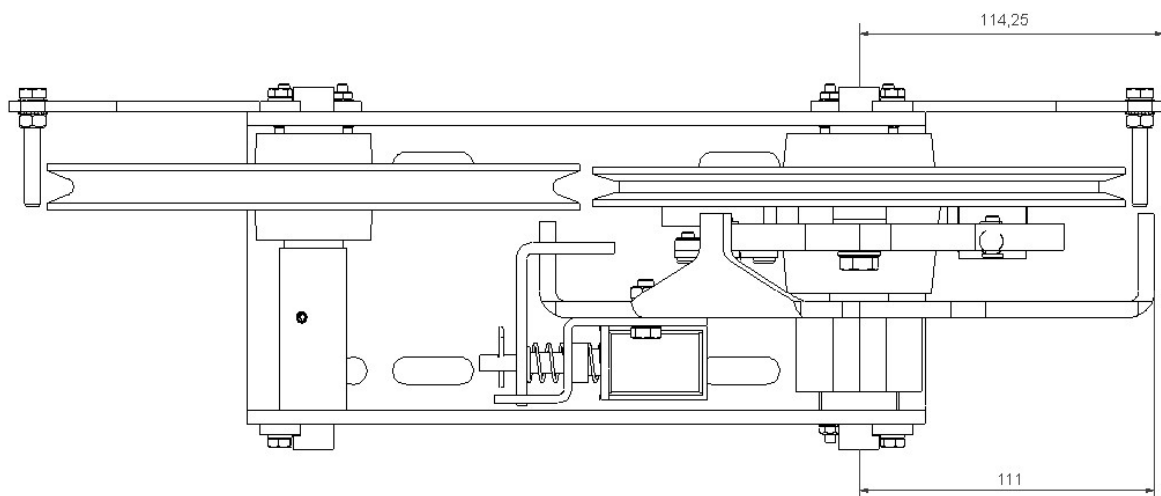

Side view:

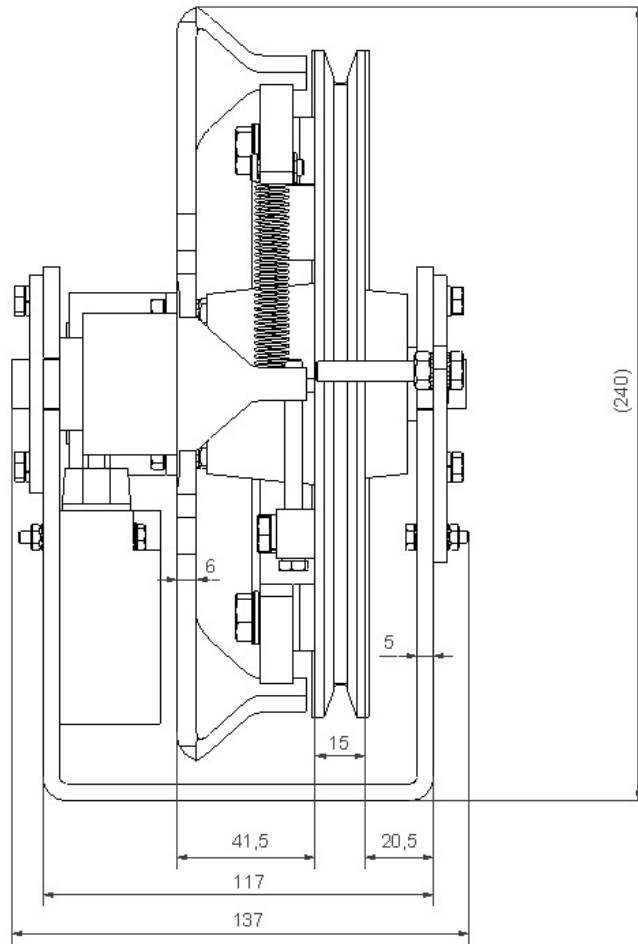



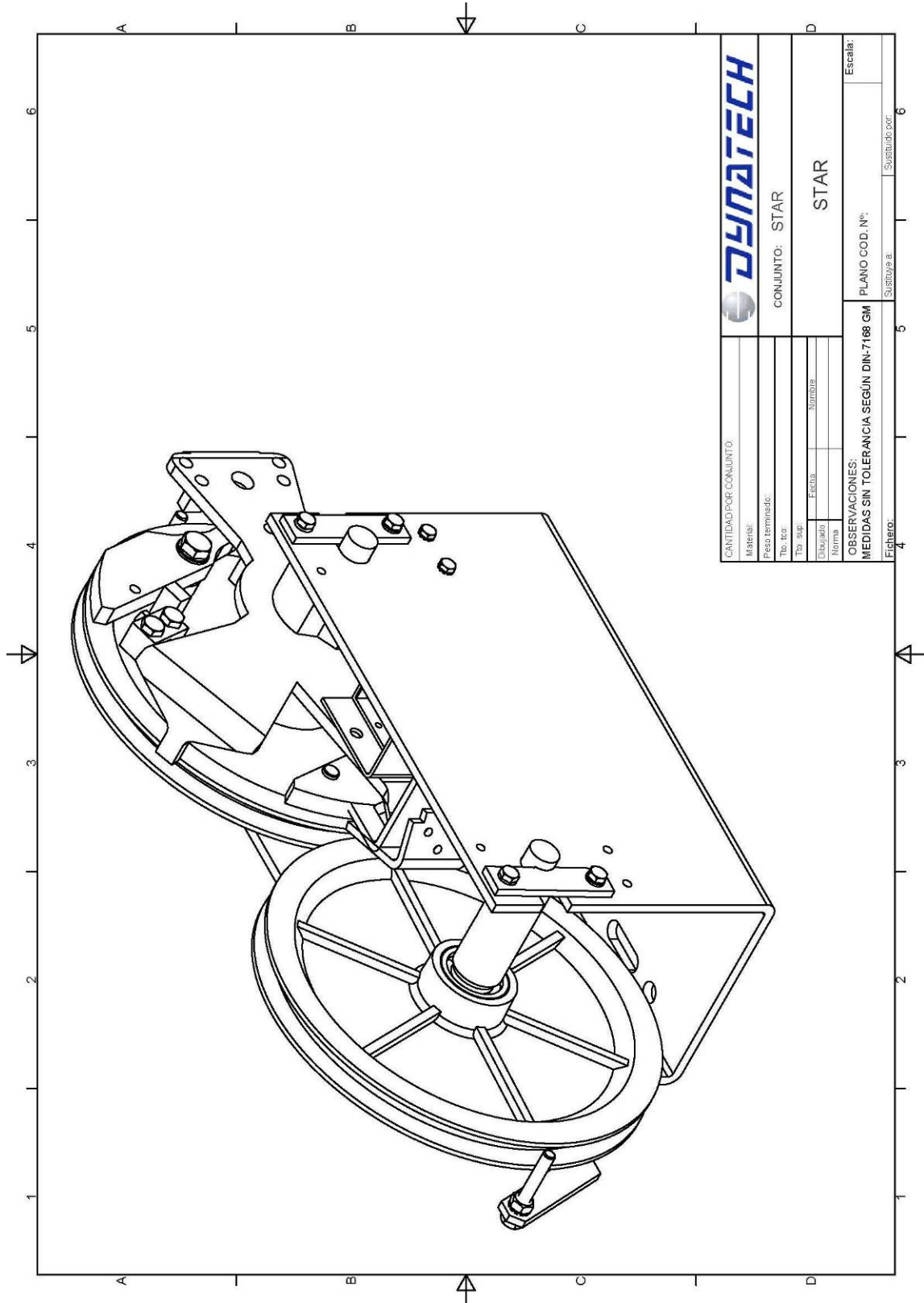

CANTIDAD POR CONJUNTO:		
Material:		
Preso terminado:		CONJUNTO: STAR
Bo. Ica:		STAR
Bo. Esp:		
Bo. Sali:		
Bo. Sali:	Encaje:	PLANO COD. N°:
Bo. Sali:	Nombre:	
OBSERVACIONES:		Escala:
MEDIDAS SIN TOLERANCIA SEGUN DIN-7168 GM		Sustituye a:
Fichero:		Sustituido por: